

Hamilton Beach COMMERCIAL

Global Foodservice Equipment Catalog





Consistently providing thoughtful products, meaningful innovation, and long-lasting durability
...now that's **Good Thinking**®



Beverage Prep

4-5	908®/909 Blenders
6-7	Rio® Blenders
8-9	Tango® Blenders
10-11	Fury™ Blenders
12-13	Tempest® Blenders
14-15	Eclipse™ Blenders
16-17	Summit® Blenders
18-19	Container Rinser
20-21	Revolution® Ice Shaver/Blender
22-23	SmartServe® Blend-In-Cup
24-25	PrimePour™ Cocktails On Tap
26-27	Drink Mixers
28-29	Wall-Mount Drink Mixer
30-31	Mix 'n Chill® Drink Mixers

Food Prep



32-33	Immersion Blender
34-35	HBF500 / HBF500S Culinary Blender
36-37	HBF600 / HBF600S Culinary Blender
38-39	HBF1100S 4L/1 Gallon Culinary Blender
40-41	Juicers
42-43	Dishers
44-45	Brewstation® Coffee Urns

Accessories











46-50	Accessories
-------	-------------

Which BLENDER is RIGHT for YOU?

Bar Basics		Smooth Results with Wave Action		Set The Time & Walk Away
908®	909	RIO®		TANGO®
HBB908 Series	HBB909	HBB250 Series	HBB250S Series	HBH450 Series
				

Application	Frozen Drinks			
Ice	Small or Crushed Ice			
Typical Drinks/Day	1 to 15	15 to 25		20 to 50
Average Time	25 Seconds	20 Seconds		15 Seconds
Power	1/2 Peak Hp†		3/4 Peak Hp†	
Jar Capacity	44 oz / 1.25 L	32 oz / .95 L	44 oz / 1.25 L	32 oz / .95 L
Drive Coupling	Rubber Clutch			Metal Clutch
Good Thinking® Features	Dependable and easy to use		Wave~Action® System for smooth results	
				Adjustable timer provides hands-free blending
Warranty	1 Year		2 Years	
				2 Years*



Powerful Workhorse		Quiet & Customized		High Volume		Automated Savings
FURY™	TEMPEST®	ECLIPSE™	SUMMIT® with Auto Blend	REVOLUTION® Shaver Blender		SMARTSERVE® Blend-in-cup
HBH550 Series	HBH650 Series	HBH750 Series	HBH850 Series	HBS1200 Series (230V)	HBS1400 (120V)	BIC2000 Series
						
Smoothies and Frozen Drinks						
Half or Full Cube Ice						Nugget Ice
50+	50+	75+	75+	100+	Up to 60 drinks per hour	
12 Seconds	12 Seconds	12 Seconds	12 Seconds	15 Seconds	Depends on recipe and cup type	
3 Hp	3 Hp	3 Peak Hp †	3 Hp	3 Hp	---	
64 oz / 1.8 L	64 oz / 1.8 L	48 oz / 1.4 L	64 oz / 1.8 L	64 oz / 1.8 L	Blends in your own cups!	
Metal Clutch						N/A
Powerful precision blending with easy-to-use paddle switches	Loaded with features and powerful performance	QuietBlend™ technology-blend at the noise level of a normal conversation	One-touch blending with AutoBlend™	Always the correct amount of ice with the Revolution® portion system		No more blender jars and an efficient blending process
3 Years* 				2 years or 25K cycles* 		1 year**



*Express Care (US Only)
First 2 years

† Peak power is Input Power



Lifetime warranty on blade and drive coupling

** Please contact your local representative for detailed warranty information.

See back of catalog for all Express Care and Global Care warranty details.

16 oz/0.5 L
margarita
in 25
seconds

Good Thinking®



HBB908[®] Series/HBB909 Blenders



HBB908[®]

AVAILABILITY:



120V



230V

HBB909

AVAILABILITY:



120V



230V

UNIQUE FEATURES

908[®] Blender

25 Second Margarita - When thirsty customers are waiting, you can blend 16 oz./0.5 L drinks in 25 seconds flat.

Two Speeds - Offer versatility and precision blending for a wide variety of drinks.

Durable Stainless Steel Blades - Four stainless steel blades are made to last and get the job done fast.

44 oz./1.25 L Container - Break-resistant polycarbonate container with filler-cap and easy-to-read measurement marks makes filling and pouring easy.

Specifications:

Standard: Unit comes with base, 44 oz./1.25 L polycarbonate container with filler cap, Sure Grip™ feet, and blade assembly unit.

Controls: High/Low

Motor: 1/2 peak Hp*

Weight: 7.25 lbs/3.28 kg

Warranty: 1 year parts & labor



120V Specifications:

120V~, 60 HZ, 3.5A



230V Specifications:

HBB908-CE

HBB908-UK

RoHS COMPLIANT



220-240V~, 50-60 HZ, 400W

909 Blender

25 Second Margarita - When thirsty customers are waiting, you can blend 16 oz. drinks in 25 seconds flat.

Two Speeds - Offer versatility and precision blending for a wide variety of drinks.

Durable Stainless Steel Blades - Four stainless steel blades are made to last and get the job done fast.

32 oz. Stainless Steel Container - Durable stainless steel offers long-lasting performance.

Specifications:

Standard: Unit comes with base, 32oz. stainless steel container with filler cap, Sure Grip™ feet, and blade assembly unit.

Controls: High/Low

Motor: 1/2 peak Hp*

Weight: 7.51 lbs

Warranty: 1 year parts & labor



120V Specifications:

120V~, 60 HZ, 3.5A



* Input power



Sure Grip™ feet hold blender securely in place



Stainless steel blades quickly cut through ice and other ingredients



Removable filler-cap lets you add ingredients while blending

No
more
ice
chunks

with
Wave~Action®
System

Good Thinking®



HBB250 / HBB250S Series

Rio®

Bar Blenders



AVAILABILITY:

HBB250



120V



230V

HBB250S



AVAILABILITY:

120V



230V

UNIQUE FEATURES

Rio® Blenders

Wave~Action® System - Ordinary blenders spin contents around the walls of the jar, which can leave whole chunks untouched by the blades. The Wave~Action® System has a unique container and blade design for smooth results every time.

20 Second Margarita - When thirsty customers are waiting, you can blend 16 oz./0.5 L drinks in 20 seconds flat.

Two Speeds with Pulse Option - Offers versatility and precision blending for a wide variety of drinks.

Durable Stainless Steel Blades - Four stainless steel blades are made to last and get the job done fast.

Jar Pad Sensor - Turns off motor when container is not in place to reduce clutch grinding (230V only).

Specifications:

Standard: Unit comes with base, container, Sure Grip™ feet, and blade assembly.

Controls: High/Low/ Pulse option Motor: 3/4 peak Hp*

Warranty: 2 year parts & labor

* Input power

HBB250 Series

44 oz./1.25 L Stackable Container

Break-resistant polycarbonate container with easy-to-read measurement marks is stackable for storage.



Weight: 9.7 lbs/4.4 kg (shipping)

120V Specifications:

HBB250R



120V~, 60 HZ, 4A

230V Specifications:

HBB250-CE

HBB250-UK

HBB250-CCC



220-240V~, 50-60 HZ, 450W

HBB250S Series

32 oz./0.95 L Stainless Steel Container

Durable stainless steel offers long-lasting performance.



Weight: 10 lbs/4.5 kg (shipping)

120V Specifications:

HBB250SR



120V~, 60 HZ, 4A

230V Specifications:

HBB250S-CE

HBB250S-UK

HBB250S-CCC



220-240V~, 50-60 HZ, 450W



Wave~Action® system continually forces mixture down into the blades for smooth results



Four stainless steel cutting and mixing blades quickly cut through ice and other ingredients

No
more
ice
chunks

with
Wave~Action®
System

Good Thinking®



HBH450 Series Tango® Bar Blender



AVAILABILITY:

HBH450



120V



230V

UNIQUE FEATURES

Tango® Blender

Wave~Action® System - Ordinary blenders spin contents around the walls of the jar, which can leave whole chunks untouched by the blades. The Wave~Action® System has a unique container and blade design for smooth results every time.

15 Second Margarita - When thirsty customers are waiting, you can blend 16 oz./0.5 L drinks in 15 seconds flat.

Timer & Two Speeds with Pulse Option - The timer is indispensable for busy bars. Two speeds offer precision blending for a wide variety of drinks.

Durable Stainless Steel Blades - Four stainless steel blades are made to last and get the job done fast.

48 oz./1.4 L Stackable Container - Break-resistant polycarbonate container with easy-to-read measurement marks is stackable for storage.

Specifications:

Standard: Unit comes with base, 48 oz./1.4 L polycarbonate container, Sure Grip™ feet, and blade assembly unit.

Controls: 2 speed/timer/pulse

Motor: 1 Hp

Weight: 11.7 lbs/
5.3 kg (shipping)

Warranty: 2 years parts
and labor



120V Specifications: 120V~, 60 HZ, 6 A
HBH450R



230V Specifications:

HBH450-CE
HBH450-UK
HBH450-CCC



RoHS COMPLIANT



220-240V~, 50-60 HZ, 600W



Timer with automatic shutoff offers precision blending control for every kind of drink



Wave~Action® system continually forces mixture down into the blades for smooth results



Four stainless steel cutting and mixing blades quickly cut through ice and other ingredients



Stackable polycarbonate jar stores in less space



All-metal drive coupling offers long-lasting performance

Powerful
Precision
Blending

with
3 Hp
Motor

Good Thinking®



Includes
**Lifetime
Warranty**
on the blade and
motor coupling

HBH550 Series Fury™ High-Performance Drink Blender



AVAILABILITY:

HBH550



120V



230V

UNIQUE FEATURES

Fury® Blender

Wave~Action® System - Ordinary blenders spin contents around the walls of the jar, which can leave whole chunks untouched by the blades. The Wave~Action® System has a unique container and blade system for smooth results every time.

Super-Creamy Drink Profile - The Wave~Action® System, along with speed and blade design, break down ice from a granita texture to a creamy drink profile.

Two Speeds Plus Pulse Button - Offers precision blending for a wide variety of drink mixtures.

Timer with Automatic Shutoff - Indispensable for busy bars, it frees operators up for other tasks.

3 Hp Motor - Built with a durable all-metal drive coupling to satisfy the demands of the busiest bars.

64 oz./1.8 L Stackable Container - Break-resistant polycarbonate container with easy-to-read measurement marks.

Specifications:

Standard: unit comes with base, one 1.8L/64oz container

Controls: High/Low/Pulse, Timer

Motor: 3 Hp

Weight: 13.9 lbs/6.3 kg (shipping)

Warranty: 3 years parts and labor



First 2 years



120V Specifications:

HBH550

120V~, 60 HZ, 13 A



230V Specifications:

HBH550-CE

HBH550-UK

HBH550-CCC



RoHS COMPLIANT



220-240V~, 50-60 HZ, 880W



Timer with automatic shutoff; 2 speeds plus pulse button



Stackable 64 oz/1.8 L break-resistant polycarbonate container



Wave~Action® system continually forces mixture down into the blades for smooth results



Durable all-metal drive coupling

Performance
and
Durability

loaded with
the features
you need

Good Thinking®

Hamilton Beach
COMMERCIAL

Includes
**Lifetime
Warranty**
on the blade and
motor coupling

HBH650 Series Tempest® High-Performance Blender



AVAILABILITY:

HBH650



120V



230V

UNIQUE FEATURES

Tempest® Blender

Wave~Action® System - Ordinary blenders spin contents around the walls of the jar, which can leave whole chunks untouched by the blades. The Wave~Action® System has a unique container and blade system for smooth results every time.

12 Second Margarita - When thirsty customers are waiting, you can blend 16 oz./0.5 L drinks in 12 seconds flat.

Super-Creamy Drink Profile - The Wave~Action® System, along with speed and blade design, break down ice from a granita texture to a creamy drink profile.

Two Speeds, Jump Cycle & Pulse Button - Offers precision blending for a wide variety of drink mixtures.

Timer with Automatic Shutoff - Indispensable for busy bars, it frees operators up for other tasks.

3 Hp Motor - Built with a durable all-metal drive coupling to satisfy the demands of the busiest bars.

64 oz./1.8 L Stackable Container - Break-resistant polycarbonate container with easy-to-read measurement marks.

Specifications:

Standard: Unit comes with base, 64 oz./1.8 L polycarbonate container, Sure Grip™ feet, and blade assembly unit

Controls: 2 speeds, jump cycle & timer

Motor: 3 Hp

Weight: 13.9 lbs/6.3 kg (shipping)

Warranty: 3 years parts and labor



First 2 years



120V Specifications:

HBH650

120V~, 60 HZ, 13 A



230V Specifications:

HBH650-CE

HBH650-UK

HBH650-CCC



RoHS COMPLIANT



220-240V~, 50-60 HZ, 880W



Blinking red light indicates when container is not in place. Motor turns off to prevent careless clutch grinding



Accessory CK650 allows the Tempest® to be mounted in the counter for reduced noise levels and a lower profile



Two speeds, jump cycle, pulse button, and timer with automatic shutoff for maximum drink versatility



Wave~Action® system continually forces mixture down into the blades for smooth results



Temperature gauge alerts operator if motor overheats to help prevent unnecessary burnout. NOTE: Operation manual shows operators step-by-step how to run the cool-down cycle

64 oz. / 2 L
Jar Now
Available

Quiet
and
Powerful

with
QuietBlend™
Technology

Good Thinking®



Includes
**Lifetime
Warranty**
on the blade and
motor coupling

HBH750 Series Eclipse™ High-Performance Blender



AVAILABILITY:

HBH750



120V



230V

UNIQUE FEATURES

Eclipse® Blender

QuietBlend™ Technology - Greatly reduces motor noise and works with the advanced Quiet Shield™ enclosure to lower sound to conversation level.

Compact Size - Blender width of 8.5" / 22cm fits neatly on top of counter. The Quiet Shield™ enclosure opens to a maximum height of just 22" / 56 cm.

Powerful Motor - 3 peak Hp† motor with a special airflow design that helps prevent motor overheating and helps extend motor life.

Pre-programmed Cycles - Choose from 5 buttons for popular drinks and over 100 additional cycles. Custom programs are available and easily downloaded with a memory card.

Jar Pad Sensor - Turns off motor when container is not in place to reduce grinding and "wear and tear" from operator misuse (120V only).

Quiet Shield™ Sensor - Turns off motor when operator lifts Quiet Shield™ (can be disabled on 120V .)

Lifetime Warranty on Motor Drive Coupling and Stainless Steel Blade - Ensures that the parts are free from defects in material and workmanship for the life of the part.

Wave~Action® System - Unique container design continually forces mixture down into the blades for a super-creamy drink profile every time.

Overheat Protection - Display alerts operator if motor overheats and provides directions to run a quick cool-down cycle.

† Input power

Specifications:

Standard: Unit comes with base, one 48 oz./ 1.4 L polycarbonate container, Quiet Shield™ sound enclosure

Controls: Touchpad

Motor: 3 peak Hp (input power)

Weight: 19.8 lbs / 9 kg (shipping)

Warranty: 3 years parts and labor



120V Specifications: 120V~, 60 HZ, 8.6 A
HBH750



230V Specifications:

HBH750-CE

HBH750-UK

HBH750-CN



220-240V~, 50-60 HZ, 1000W



Converts for in-counter use

Easy-read display and intuitive, one-touch blending functions



Convenient clips allow for easy removal of Quiet Shield™ for cleanup

Quiet Shield™ opens to a max height of only 22 inches/56 cm

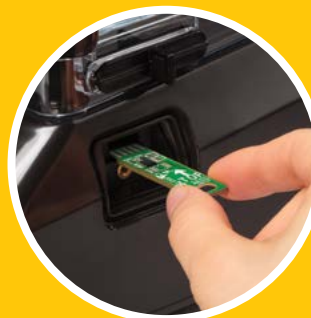

Memory card for custom programming

One touch
to perfect
consistency

with
Auto Blend

Good Thinking®



Hamilton Beach
COMMERCIAL



Includes
**Lifetime
Warranty**
on the blade and
motor coupling

HBH850 Series Summit® High-Performance Blender



AVAILABILITY:

HBH850



120V



230V

UNIQUE FEATURES

Summit® Blender

Auto Blend "One Touch Sensor Blending" - Patent-pending technology continuously monitors blender's power usage and speed to determine when the perfect drink consistency is achieved.

Hundreds of Pre-programmed Cycles - Reduces the need to select different cycles for different drinks to free up decision-making time.

Quiet Shield™ Sound Enclosure - reduces blender noise.

Super-Creamy Drink Profile - The Wave~Action® System, along with speed and blade design, break down ice from a granita texture to a creamy drink profile.

Cavitation Control - Detects when cavitation occurs and prompts the operator to add more liquid. Keeps the operator from spending time watching the blender and from serving a bad drink.

Airflow Baffle - Constantly circulates cool air around the motor for back-to-back blending and longer blender life.

Jar Pad Sensor - Turns off motor when container is not in place to reduce grinding and "wear and tear" from misuse. (120V only)

Quiet Shield™ Sensor - turns off motor when operator lifts Quiet Shield (230V only).

Specifications:

Standard: Unit comes with base, one 64 oz./1.8 L stackable polycarbonate container, sealing gasket, Quiet Shield™ sound enclosure.

Controls: Touchpad

Motor: 3 Hp

Weight: 23.32 lbs /
10.57 kg (shipping)

Warranty: 3 years parts
and labor



U.S. ONLY
First 2 years



120V Specifications: 120V~, 60 HZ, 13 A
HBH850



230V Specifications:

HBH850-CE
HBH850-UK
HBH850-CCC



220-240V~, 50-60 HZ, 880W



Auto Blend stops blender when drinks reach the perfect consistency



Dual fans automatically keep motor cool in-between blends

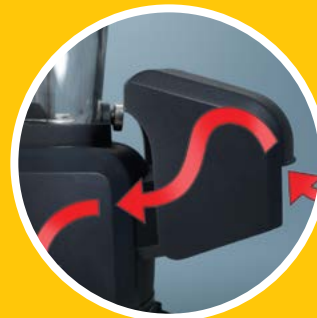

Unique airflow baffle keeps motor cool and prevents water ingress



USB Port for future program updates



Converts for in-counter use

Clean Jars
in
Seconds

No More
Manual
Rinsing

Good Thinking®



BCR100 Container Rinsers



BCR100

Designed To Rinse Various Containers -

Rinses all jars, cups and containers up to 64oz/2L

Durable Construction - Stainless steel spray nozzle; break-resistant polycarbonate

Easy Operation - A gentle push on platform activates spray

Compact and Low Profile Design - Fits easily in sink at 6.25" / 160 mm square and 5.25" / 133 mm high

Raised Nozzle - For better cleaning

Suction Cup Feet - Hold rinsers securely in place

Specifications:

Unit comes with base, nozzle, hose

Base: break-resistant polycarbonate; with 4 suction cups
2.5 ft. / 0.7 m flexible 3/8" / 10 mm (ID) reinforced tubing with swivel garden hose (GHT) fitting

Press down to activate

No electricity required

Flow rate: 2.25 gpm / 8.521 pm (@ 60 psi)

Weight: 1.2 lbs / 0.5 kg (shipping)

Warranty: 1 year parts & labor

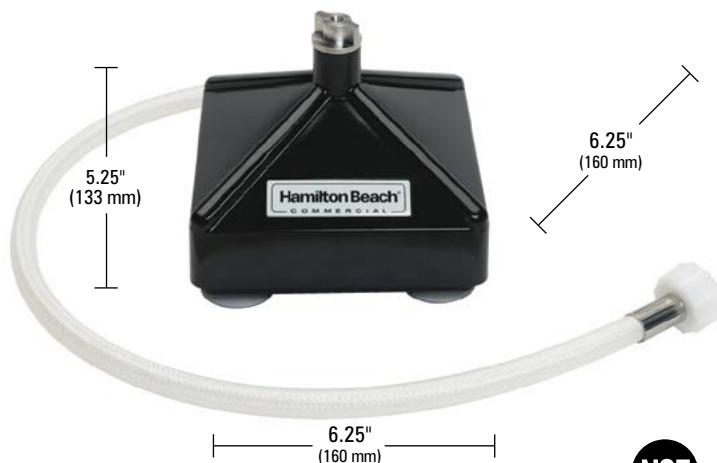

**Save Time.
Conserve Water.
Reduce Costs.**



A gentle push on platform
activates spray

Always
the correct
amount
of ice

with the
Revolution®
portion
system

Good Thinking®

Includes
**Lifetime
Warranty**
on the blade and
motor coupling

HBS1400/1200 Series Revolution® Ice Shaver / Blender



AVAILABILITY:

HBS1400/HBS1200



120V



230V

UNIQUE FEATURES

Revolution® Ice Shaver/Blender

Revolution® Portion System - For maximum accuracy, this unique ice portioning system counts the number of times the agitator passes the shaver blade. Regardless of the motor load, the correct amount of ice comes out every time!

Systems that calculate portions by time or weight may not be delivering consistent drink quality to your customers. Time systems don't reliably shave the right amount of ice because the motor speed will vary with the load (the motor may spin more slowly when the ice hopper is full). Systems that rely on just the weight of ice can be inaccurate during blending because of container movement. The Revolution® Portion System eliminates these concerns, delivering the right amount of ice every time.

Double-Wall Hopper - Insulated for quiet operation and to keep ice cold.

Sensor Technology - Hopper sensor prevents operation when lid is not in place. Drain sensor indicates if water is backed up in the drain. This alerts the operator to check the drain line and can prevent a messy water back-up.

3 Hp Blender Motor - Powerful, heavy-duty, and built to satisfy the demands of the busiest bars.

Automatic Cycle Buttons - Operators select serving size and number of servings for precise results.

Specifications:

Standard: Unit comes with base, ice chute, 2 piece hopper with lid (5 gallon/19 L), 64 oz./1.8 L polycarbonate container, and leveling feet

Controls: Touchpad

Motors: 3 Hp blender, 1/4 Hp shaver

Weight: 71 lbs / 32.2 kg (shipping)

Warranty: 2 years parts and labor or 25,000 cycles



HBS1400

120V Specifications: 120V~, 60 HZ, 15 A



HBS1200

230V Specifications:



HBS1200-CE

HBS1200-UK

HBS1200-CCC

220-240V~, 50-60 HZ, 1,000W



Insulated double-wall hopper reduces noise and keeps ice cold (showing inner hopper only)



The Wave~Action® system continually forces mixture down into the blades for smooth results every time



A press of the automatic cycle buttons sets the right serving size and number of servings



Comes with a stackable 64 oz./1.8 L polycarbonate container (6126-650)



Long-lasting clutch seal shields the internal parts from moisture

Say
Goodbye
to Blender
Jars

with
blend-in-cup
technology

Good Thinking®



Can be
configured
to make
MILKSHAKES

MIC2000

BIC2000 Series SmartServe® Blend-in-Cup with Self-Rinsing



AVAILABILITY:

BIC2000



UNIQUE FEATURES

SmartServe® Blend-In-Cup Machine

Blends in your disposable cups - Everything you put into the cup is served to the customer, no more wasted ingredients left in blender jars.

No Dispensing - The step of pouring from the blender jar is completely eliminated.

Simple process - Dispense ingredients into cup, insert cup and press "start", serve the customer. Equipment automatically rinses itself.

Water Savings - Rinses with as little as 10 oz./300 mL of water. Compared with manual cleaning, SmartServe™ can cut water usage by 8X.

Labor Saving - SmartServe™ has an output of more than a drink a minute.

Space/Jar Saving - Requires just approximately 7.5" of counter width plus no more blender jars to store.

Consistent Output - Blends using a perfectly controlled and consistent process every time. Blend parameters can be changed easily via USB port.

Specifications:

Controls: Touchpad with USB port for program changes

Weight: 90 lbs / 22.7 kg (shipping)

Warranty: 1 year**



120V Specifications:

120V~, 60 HZ, 7A

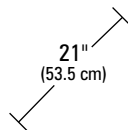

36.25"
(92 cm)

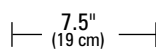

230V Specifications:

BIC2000-CE
BIC2000-UK
BIC2000-CN



220-240V~, 50-60 HZ, 3.5A

**Please contact your local representative for detailed warranty information.

Step 1:

Add ingredients to your cup. Can include nugget ice, frozen fruit packets, fruit concentrate, etc.



Step 2:

Insert cup into machine, press start. SmartServe™ automatically blends your drink to the perfect consistency.



Step 3:

After the blend cycle is complete, serve blended drink to customer. SmartServe™ then automatically rinses itself to prepare for the next drink.



Flexibility:

SmartServe™ can be customized via a USB port to accommodate your cups and menu items.



Ease of use:

Different control panel covers can limit the number of keys the operator sees, while allowing management access to all functions.



Easy to install:

Accepts standard water line for rinse water and standard PVC drain line.

Image shows 2 PrimePour™ units in use



**Fast &
Consistent**

Complex cocktails
made easy

with
precise portion
control

Good Thinking®



With just a pull of the tap,
spirits are perfectly blended
with premium cocktail mixes
to make high-quality drinks
every time. No mixology
experience required.

Under-the-bar unit

COT2000

PrimePour™

Cocktails On Tap



COT2000

PrimePour™

Speed - Pouring a cocktail in seconds means less wait time for customers and increased sales.

Portion and Quality Control - exact calibration of mix and spirit offers consistent taste profile.

Designer Tap Towers - Eye-catching single or double towers with convenient drip tray for a neat bartop.

Simple Installation - Platform slides onto bartop without tools and attaches to supply box underneath.

Automatic Pump Shutoff - when mix is empty to ensure that spirit is not wasted.

Slide-Out Bottle Tray - holds three 1 liter or 750 ml bottles securely and makes refilling easy.

Spirit Level Window - Lets you easily view level to know when to refill.

Easy to Resupply and Clean - Drink mix bag-in-box connects with QCD.

CO₂ Powered - No electricity is required, allowing unit to be completely portable with a small CO₂ tank.

Small Footprint

COT2000

Specifications:

Standard: Unit comes with base and single tap tower with platform

Weight: 84 lbs / 38 kg (shipping)

Warranty: Option to purchase up to 4 years



UNIQUE FEATURES



Designer Tap Towers

Eye-catching towers with convenient drip tray for a neat bartop



Spirit level view window

Slide-Out Bottle Tray

Holds three 1 liter or 750 ml bottles securely and makes refilling easy



Plastic Drink Mix Container Available for custom mixes (DMC2000)

A Hamilton Beach Commercial water dispenser with three hot water faucets and three cold water faucets. The dispenser is stainless steel and has a 'Hamilton Beach COMMERCIAL' logo on the top. A stainless steel cup is on the right. The background is a blue-tinted kitchen setting with a glass pitcher on the left.

Hamilton Beach
COMMERCIAL

Minimize
downtime

with easy
to replace
quick-connect
motor

Good Thinking®

HMD200 / HMD400 Series Drink Mixers Single & Triple Spindle



AVAILABILITY:

HMD200



120V



230V

AVAILABILITY:

HMD400



120V



230V

UNIQUE FEATURES

Single-Spindle Mixer

Versatile Drink and Food Prep - Great for everything from mixing ice cream shakes to "flashing" bar drinks to blending eggs, pancake, and waffle batter.

Performance - More powerful 1/3 Hp motor mixes up to twice as fast, so customers don't have to wait.

Precision Motor - The motor is balanced to minimize vibration. Built to last with sealed, permanently lubricated ball bearings.

Two-Way Motor Activation - Operators can start and stop mixing action by inserting the cup into the cup guide, or by using the pulse switch on the top of the mixer (pulse is 120V only).

Specifications:

Standard: Unit comes with base, motor, spindle, solid agitator, and stainless steel cup.

Controls: 3-speed rocker switch and unique pulse switch (120V only)

Motor: 1/3 Hp

Weight: 15.4 lbs / 7.0 kg (shipping)

Warranty: 1 year parts & labor



120V Specifications:

120V~, 60 HZ, 300W



230V Specifications:

HMD200-CE

HMD200-UK

HMD200-CCC



220-240V~, 50-60 HZ, 300W

Triple-Spindle Mixer

Optimum Output - The ideal choice for high-volume milkshake prep.

Performance - 1/3 Hp motors mix up to twice as fast, to maximize service and minimize the wait.

3 Separate Motors - Each motor works independently and has its own power switch.

Precision Motors - Each motor is individually balanced to minimize vibration. All three motors are built to last with sealed, permanently lubricated ball bearings.

Two-Way Motor Activation - Operators can start and stop mixing action by inserting the cup into the cup guide, or by using the pulse switch on the top of the mixer (pulse is 120V only).

Specifications:

Standard: Unit comes with base, 3 motors, 3 spindles, 3 solid agitators, and 3 stainless steel cups.

Controls: 3-speed rocker switch and unique pulse switches (120V only)

Motors: 1/3 Hp on each motor

Weight: 37 lbs / 16.783 kg (shipping)

Warranty: 1 year parts & labor



120V Specifications:

120V~, 60 HZ, 900W



230V Specifications:

HMD400-CE

HMD400-UK

HMD400-CCC



220-240V~, 50-60 HZ, 900W



3 speed switch plus unique fingertip-action pulse switch that stops and starts the motor (pulse is 120V only)



Operator can easily replace motor in minutes



Removable cup guide pulls out for easy dishwasher cleanup

A Hamilton Beach Commercial mixer is mounted on a wall. The mixer is dark grey with a stainless steel mixing arm and a vertical stainless steel support. A silver label on the top of the mixer reads "Hamilton Beach" and "COMMERCIAL". The mixer is mounted on a dark grey metal plate. The background is a blurred stainless steel kitchen environment.

Hamilton Beach
COMMERCIAL

Save
Counter
Space

with
Wall-Mount
Construction

Good Thinking®

HMD300 Series Wall Mount Drink Mixer



AVAILABILITY:

HMD300



120V



230V

UNIQUE FEATURES

Wall-Mount Single-Spindle Mixer

Powerful 1/3 Hp Motor - Built to last with permanently sealed ball bearings. Can be replaced by operator to avoid downtime.

Easy Wall Mount - All hardware included. Plugs into standard outlet.

Two-Way Motor Activation - Operators can start and stop mixing action by inserting the cup into the cup guide, or by using the pulse switch on the top of the mixer (120V only).

Speed Switch - Offers flexibility for different menu items.

Easy To Clean - Removable cup guide and cup rest.

Built To Last - Heavy-duty, die cast, stainless steel construction.

Versatile Drink and Food Prep - Great for everything from mixing ice cream shakes to "flashing" bar drinks to blending eggs, pancake, and waffle batter.



With two-way motor activation, operators can start and stop mixing action by inserting the cup into the cup guide, or by using the pulse switch on the top of the mixer (120V only)



Speed switch offers flexibility for different menu items



Removable cup guide pulls out for easy dishwasher cleanup.

Specifications:

Standard: Unit comes with base, all mounting hardware, spindle with 990043600 agitator and stainless-steel cup

Controls: On/off pulse switch (120V only); High/Low switch

Motor: 1/3 Hp

Weight: 10.5 lbs / 4.76 kg (shipping)

Warranty: 1 year parts & labor

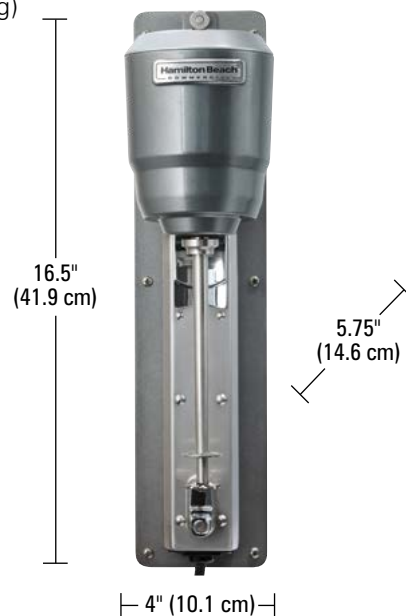

120V Specifications:
HMD300



120V~, 60 HZ, 250 W

230V Specifications:
HMD300-CE
HMD300-UK

RoHS COMPLIANT



220-240V~, 50-60 HZ, 250 W



**HMD300M-220
MACHINE-MOUNT MIXER
ALSO AVAILABLE**

Please contact your local representative for details

Easy
one-hand
activation

with
Smart-Start™
mixing shaft

Good Thinking®



Hamilton Beach
COMMERCIAL

Mix'n CHILL™

WARNING

Cut Hazard
Always use collar when operating with paper cup. Always use shield when mixing. Failure to follow these instructions can result in broken bones or cuts. *Inspect agitator daily for wear.

Do not put spoon or other utensils in cup when mixing. Agitator will spin if timer is set to FP and no foot pedal is connected. Always connect a foot pedal before setting timer to FP. **Replace agitator every 30 days.

PROGRAM: C, D, E, F, G, MANUAL

SPEED: 10, 20, 30, 40, 50, 60, 70, 80, 100

START STOP
PULSE

Mix 'n Chill®

Drink Mixers



AVAILABILITY:

HMD900



120V



230V

UNIQUE FEATURES

Mix 'n Chill®

One-Hand Activation - To start the motor, put the filled cup under the mixing shaft and push.

Performance - 3/4 Hp motor provides heavy-duty mixing action.

Easy To Clean - Stainless steel pan removes easily without the use of tools and is dishwasher safe.

Consistent Results - Pre-programmed cycles deliver consistent mixing results regardless of the operator.

User Friendly - Contoured splash shield reduces discomfort on the operator's wrist and easily removes for cleaning.

Dependability - Ice cream companies and restaurateurs worldwide consider this drink mixer the standard because of its dependable performance.

Specifications:

Standard: Unit comes with base, spindle with 929 agitator, splash shield, and removable stainless steel pan

Controls: On/off rocker switch; rotary dial with variable speed selections and pre-programmed cycles

Motor: 3/4 Hp

Weight: 33.6 lbs / 15.2 kg (shipping)

Warranty: 1 year parts & labor



Stainless steel pan is easily removed for easy cleanup



929 agitator maximizes mixing performance for hard- and soft-serve ice cream and is especially good for candy mix-ins

See page 51 for additional agitator choices

120V



120V Specifications:

HMD900



120V~, 60 HZ, 6.4A

230V



230V Specifications:

HMD900-CE
HMD900-UK
HMD900-CN



RoHS COMPLIANT



220-240V~, 50-60 HZ, 7A

94950 Mix 'n Chill® - Still Available

- Variable Speed
- Removable Splash Pan
- 3/4 Hp Motor



120V Specifications:

94950



120V~, 60 HZ, 5.2A

31

*Meets IPX3 moisture protection with added hood



Autoclavable
for quick
sterilization

with
detachable
two-piece
construction

Good Thinking®

HMI200 Series Immersion Blender Heavy Duty



HMI200

AVAILABILITY:



UNIQUE FEATURES

Immersion Blender

Heavy Duty - Long-life motor construction and stainless steel chopping attachment designed for foodservice applications.

Flexibility - Detachable chopping attachment plus two speeds give professional kitchens the flexibility they need to purée soups and sauces right in the pan, whip egg whites, cream butters & mix batters with ease.

Stainless Steel 9"/23 cm Shaft - Not only does the thick 9"/23 cm shaft reach into deep pots and bowls, it detaches for easy cleaning.

Innovative Blade Guard - Keeps prep areas neat and saves time by reducing messy splashing and clogging.

Double-Insulated - With two-conductor cord for easier use and storage.

Specifications:

Standard: Motor unit, detachable 9"/23 cm chopping shaft and cutting blades

Controls: 2-speed switch

Motor: 175 Watts

Weight: 4.2 lbs / 1.9 kg (shipping)

Warranty: 1 year parts & labor



Blade guard reduces splashing and allows mix to pass through without clogging



Built-in storage hook for easy hanging and storage on wire racks



Chopping attachment detaches easily for dishwasher cleanup and is autoclavable for quick sterilization



Four blades with five cutting edges quickly cut through ingredients for professional results every time

120V Specifications:



120V~, 60 HZ, 175W

230V Specifications:

HMI200-CE
HMI200-UK
HMI200-CCC

RoHS COMPLIANT



220-240V~, 50-60 HZ, 175W

The Perfect Choice For Healthcare Applications

Another "First" by HBC - The HMI200 Immersion Blender by Hamilton Beach Commercial is the first product of its kind that can be quickly sterilized in an autoclave.



BLEND

Pesto, dressings, and remoulades



CHOP

Salsas, hummus, compotes, and vegetables



GRIND

Nuts, grains, and spices



PUREE

Soups, sauces, and coulis



EMULSIFY

Mayonnaise, dressings, and aioli



Smooth emulsion

with onboard dosing cup

Good Thinking®

EXPEDITOR™

Family of Culinary Blenders

HBF500 Series



AVAILABILITY:
HBF500 120V 230V

AVAILABILITY:
HBF500S 120V 230V

AVAILABILITY:
990 120V 230V

HBF500/HBF500S Culinary Blender

Variable Speed & Pulse Functions - for blending, pureeing, grinding, chopping, and emulsifying

Chop Function - cycles between low speed and operator-selected high speed

1 Hp Motor - has the torque needed for chopping ingredients

Patented Wave~Action® System - keeps ingredients circulating through the blades to ensure that contents are well-emulsified

All-Metal Drive Coupling - Built to last

Large Dosing Cup - Makes adding liquid for emulsions easy while blending

Stainless Steel Blades - Quickly cut through ingredients

Jar Pad Sensor - Turns off motor when container is not in place (230V Only)

Stackable 48 oz. (1.4 L) Polycarbonate Container

HBF500 Series

Standard: Unit comes with base, one polycarbonate container, dosing cup, lid.

Controls: Toggle switches, var. speed

Motor: 1 Hp

Weight: 11.3 lbs / 5.1 kg (shipping)

Warranty: 2 years parts & labor



120V Specifications:

120V~, 60 HZ, 6 A



230V Specifications:

HBF500-CE
 HBF500-UK
 HBF500-CCC



Global Care 220-240V~, 50-60 HZ, 600W

64 oz. (1.8 L) Stainless Steel Container with Comfortable, Easy-Grip Handle

HBF500S Series

Standard: Unit comes with base, stainless steel container, dosing cup, lid.

Controls: Toggle switches, var. speed

Motor: 1 Hp

Weight: 12.5 lbs / 5.9 kg (shipping)

Warranty: 2 years parts & labor



120V Specifications:

120V~, 60 HZ, 6 A



230V Specifications:

HBF500S-CE
 HBF500S-UK
 HBF500S-CCC



Global Care 220-240V~, 50-60 HZ, 600W

990 Food Blender

2 Speed Power plus Pulse - For blending, mixing, chopping - even pureeing of hot and cold foods

Durable Stainless Steel Blades - Four stainless steel cutting and mixing blades ensure quick, thorough blending. Special accessory included for easy blade removal.

Heavy-Duty Rocker Switches - Built to take the day-in and day-out abuse of a busy establishment

Sure-Grip™ Feet - Prevents skidding and won't mar countertops

1 Gallon (3.78 L) Stainless Steel Container

990 Series

Standard: Unit comes with base, stainless steel container, blade assembly unit and blade removal accessory.

Controls: Hi/Low with Pulse

Motor: 3/4 Hp

Weight: 23 lbs / 10.4 kg (shipping)

Warranty: 2 years parts & labor



120V Specifications:

120V~, 60 HZ, 3 A



One food
blender,
unlimited
options

with the
versatility
chefs
demand

Good Thinking®



Includes
**Lifetime
Warranty**
on the blade and
motor coupling



Chop



Grind



Blend



PUREE



Emulsify

EXPEDITOR™

Family of Culinary Blenders

HBF600 Series



AVAILABILITY: **HBF600** 120V 230V

AVAILABILITY: **HBF600S** 120V 230V

UNIQUE FEATURES

3 Hp Motor - has the torque needed for chopping ingredients

Large Dosing Cup - Makes adding liquid for emulsions easy while blending

Patented Wave~Action® System - keeps ingredients circulating through the blades to ensure that contents are well-emulsified

Lifetime Warranty on Motor Drive Coupling and Stainless Steel Blade - Ensures that the parts are free from defects in material and workmanship for the life of the part.

Chop Function - Cycles between low speed and operator-selected high speed

Variable Speed and Pulse Functions - For blending, pureeing, grinding, chopping, and emulsifying



Patented Jar Pad Sensor
4 magnetic connections prevent blending unless container is on correctly



One-Touch Chopping Function
cycles between low speed and operator-selected high speed



Temperature Gauge
alerts operator if motor overheats while blending back-to-back batches

HBF600 Series

Stackable 64 oz. (1.8 L) Polycarbonate Container

Standard: unit comes with base, one polycarbonate container, dosing cup, lid.

Controls: Touchpad

Motor: 3 Hp

Weight: 14 lbs / 6.4 kg (shipping)

Warranty: 3 year parts & labor



120V Specifications:

120V~, 60 HZ, 13 A



230V Specifications:

HBF600-CE
HBF600-UK
HBF600-CCC



220-240V~, 50-60 HZ, 750W

HBF600S Series

64 oz. (1.8 L) Stainless Steel Container with Comfortable, Easy-Grip Handle

Standard: unit comes with base, stainless steel container, dosing cup, lid.

Controls: Touchpad

Motor: 3 Hp

Weight: 14.21 lbs / 6.5 kg (shipping)

Warranty: 3 year parts & labor



120V Specifications:

120V~, 60 HZ, 13 A



230V Specifications:

HBF600S-CE
HBF600S-UK
HBF600S-CCC



220-240V~, 50-60 HZ, 750W

Saves prep time

with powerful, high-volume blending

Good Thinking®



Chop

Grind

Blend

PUREE

Emulsify

EXPEDITOR™

Family of Culinary Blenders

HBF1100 Series



AVAILABILITY:

HBF1100 120V 230V

AVAILABILITY:

HBF1100S 120V 230V

UNIQUE FEATURES

Saves Prep Time - From its powerful 3.5 Hp motor to its custom-designed blade and large-capacity container, the HBF1100S is fully equipped to produce great results in a fraction of the time.

Unique Chop Function - pulses the blades between low speed and chef-selected blend speed. This pulsing action keeps foods with even a small amount of liquid moving inside the jar. Perfect for hummus, salsa, smoothies, and salad dressings.

Custom Program Buttons - offer the operator a large degree of custom blending and precision control. They keep recipes consistent, freeing up valuable time. As the menu changes, program cycles are easily updated by inserting a memory card.

Variable Speed Dial - allows the blender to operate from a very low speed (perfect for salad dressings, chopping, and grinding) to a high speed that quickly creates a velvety smooth puree.

Preset Timer Buttons - Operators are free to perform other kitchen tasks by selecting from 4 timer buttons, then pressing their choice of HIGH, VARIABLE, CHOP, or PULSE.

Interlock Lid Function (HBF1100S) - Designed with safety in mind, the interlock function with indicator light ensures that the blender won't start until the jar and lid are securely in place.

Low-Profile Design - offers convenient access to container on any kitchen countertop. Also makes it easy to move the blender from one kitchen station to another.

Heavy-Duty Construction - Built for long-lasting performance in the world's busiest kitchens.



Precision-Control Touchpad
Equipped with a wide variety of controls to provide multiple possibilities for every kitchen



HBF1100S has Transparent Lid with 120 ml/4 oz. Dosing Cup
Gives chefs optimal control over food texture and consistency



Lifetime Warranty
On all-metal motor drive coupling and stainless steel blades

HBF1100 Series

4 Liter/1 Gallon Polycarbonate Container

Standard: unit comes with base, 1 gallon / 4 L polycarbonate clear container and 4 oz. / 120 ml removable dosing cup

Controls: Touchpad

Motor: 3.5 Hp

Weight: 24.3 lbs / 11 kg (shipping)

Warranty: 3 year parts & labor



120V Specifications:

120V~, 60 HZ, 14 A



HBF1100S Series

4 Liter/1 Gallon Stainless Steel Container

Standard: unit comes with base, brushed stainless steel container with overmolded handles, transparent lid, and 120 ml/4 oz. removable dosing cup

Controls: Touchpad

Motor: 3.5 Hp

Weight: 24.3 lbs / 11 kg (shipping)

Warranty: 3 year parts & labor



120V Specifications:

120V~, 60 HZ, 14 A



230V Specifications:

HBF1100S-CE

HBF1100S-UK

HBF1100S-CN



220-240V~, 50-60 HZ, 11 A

No more
food-covered
handles

with
notched
pan rest™
design

Good Thinking®

DISHER CAPACITY

Color	Disher Size	Bowl Dia.	Milliliters*	Fluid Oz.*	Fluid Oz. Fractional**	Wt./Oz.*	Patties/Lb. †	Scoops/Gal. ‡
White	6	3"	138	4.66	4 3/4	4.86	3	16
Grey	8	2 3/4"	108	3.64	3 3/4	3.80	3 1/2	22
Ivory	10	2 5/8"	94	3.19	3 1/4	3.33	4	24
Green	12	2 1/2"	82	2.78	2 3/4	2.90	5	26
Blue	16	2 1/4"	61	2.07	2	2.16	6-8	35
Yellow	20	2 1/8"	52	1.77	1 3/4	1.84	9-10	42
Red	24	2"	44	1.49	1 1/2	1.56	11-12	51
Black	30	1 3/4"	30	1.03	1	1.07	13-14	62
Orchid	40	1 1/2"	20	0.68	3/4	0.70	15-16	70

* Water Capacity ** Approximate † Hamburger Patties ‡ Ice Cream

78/80 Series Dishers Heavy Duty



78

Dishers

Heavy-Duty Stainless Steel - The bowl, thumb lever, and spring are made of stainless steel for long life and easy cleanup in the dishwasher.

Heavy-Duty Spring Action - The heavy-duty stainless steel spring allows for ease of operation and long-lasting durability.

Color-Coded Handles - Designed for instant identification and improved service, the color-coded handles let you streamline your foodservice operation. Bright, identifiable colors help maintain portion control, and make disher size selection quick and easy.

Specifications:

Warranty: 1 year parts & labor



80

Deluxe Dishers

80 dishers have all the features of the 78 line plus these extras:

Pan Rest™ Feature - These convenient notches let dishers rest on the edge of pans to help prevent slippage that could slow down service.

Ergonomic Grip - Handles are shaped for a comfortable grip that helps reduce hand and arm fatigue.

Imprinted Capacity - With the capacity clearly molded onto each handle, there's never a question which size disher is being used.

Specifications:

Warranty: 2 year parts & labor



UNIQUE FEATURES



Pan Rest™ feature on handle holds disher in place



Dishers are sold in colorful, easy-to-identify packaging

Maximum
juice,
minimum
effort

Good Thinking®



Model 932 is built with heavy-duty gears for years of durability



932's juice collector cup swings out for easy access



96700 includes 3 stainless steel reinforced reamers: 1 for lemons and limes, 1 for oranges, and 1 for grapefruit

932 / 96700 / HWG800 Series

Juicers

Manual or Motorized



932

Manual Citrus Juicer

Dependability - Considered the standard worldwide because of its hard-working, dependable performance and classic looks.

Flexibility - Designed to extract pure citrus juice from lemons, limes, oranges, and grapefruit.

Maximum Juice Extraction - The extractor arm exerts up to 2,000 lbs. of force to ensure maximum juice output with minimum skin oil and pulp residue.

Strainer Cone and Funnel - Remove for easy cleaning.

Acid-Resistant Finish - The metal components, as well as the enamel finish, resist wear and tear from exposure to citrus acids.

Specifications:

Standard: Unit comes with base, strainer cone, funnel, swing-out juice collector cup, and Sure Grip™ feet

Weight: 13.2 lbs / 6 kg (shipping)

Warranty: 1 year parts & labor



96700

AVAILABILITY: 120V 230V

Electric Citrus Juicer

3 Reinforced Reamers - Small for lemons and limes, medium for oranges, and large for grapefruits. Each reamer has a stainless steel insert for durability.

Quiet Motor - With its exceptionally quiet motor, the 96700 is a welcome addition to any establishment.

Extra-Tall Spout - Juice spout is a full 8.5"/ 21.6 cm from the counter to allow juicing into a variety of containers.

Low Center of Gravity - Makes the juicer less prone to tip over.

Durability - Heavy-duty metal housing, durable strainer, and reamers.

Specifications:

Standard: Unit comes with extra-large stainless steel bowl, acid-resistant cast aluminum base, ABS plastic strainer, and 3 reamer sizes

Controls: On/off push-button switch

Weight: 30 lbs / 13.6 kg (shipping)

Warranty: 2 year parts & labor



120V Specifications:

120V~, 60 HZ, 3A



230V Specifications:

1G96700

1G96700-UK

RoHS COMPLIANT



220-240V~, 50-60 HZ, 250W

Wheatgrass Juicer

Powerful, High-Torque Motor - For maximum juice yield

Durable Motor - Permanently lubricated and air-cooled for years of juicing

Easy Assembly - With 304 grade surgical stainless steel parts for long life

Durability - Stainless steel construction

Food Zone Parts Remove Easily - for quick cleaning

Toggle Switch - Includes reverse option for cleaning after juicing dry herbs and sprouts

Includes Stomper - For feeding longer wheatgrass

Specifications:

Standard: Unit comes with 304 grade stainless steel housing and parts, custom wrench, stomper

Controls: Toggle switch

Weight: 37 lbs / 17 kg (shipping)

Warranty: 1 year parts & labor



120V Specifications:

120V~, 60 HZ, 375 W



Conforms to NSF/ANSI STD. 8

A Hamilton Beach BrewStation commercial coffee maker is shown with its removable tank. The tank is stainless steel with a black handle and a spigot. The base is black with a stainless steel front panel. A person in a white shirt is holding the handles of the tank. The coffee maker is on a white table with stacks of white coffee cups and saucers.

Easy-Fill
Removable
Tank

for Easy
Cleanup

Good Thinking®

Brew
a full tank in
45
Seconds
per cup

HCU045S / HCU065S / HCU110S Series Brewstation® Urns with Removable Tank



AVAILABILITY:

HCU045S / HCU065S / HCU110S  120V  230V

UNIQUE FEATURES

Brewstation® Urns

- One-Hand dispensing** - fills cups fast for superior service
- Removable Tank** - for fast, easy filling and cleanup
- Boil-Dry Protection** - automatically shuts off when tank is empty
- Speed Brewing** - for fast, fresh-tasting coffee with less waste
- Fold Up/Down Handles** - for easy carrying and compact storage
- Decaf Indicator** - enables you to inform guests when decaf is being served
- Heavy-Duty Locking Clips** - securely lock tank onto base
- Corrosion-free stainless steel construction** - cleans up fast and easy



Dual heater system center heater brews coffee, then shuts off. Gentle warming heater keeps coffee at a constant serving temperature without overcooking it.

45 Cup

HCU045S

Specifications:

Standard: Removable lid tank, Brewstation® base, drip tray
Controls: On/off switch
Electrical: 120V, 60 Hz, 1400W
Weight: 12.6 lbs / 5.7 kg (ship.)
Warranty: 1 year parts/labor



65 Cup

HCU065S

Specifications:

Standard: Removable lid tank, Brewstation® base, drip tray
Controls: On/off switch
Electrical: 120V, 60 Hz, 1400W
Weight: 13.2 lbs / 6.0 kg (ship.)
Warranty: 1 year parts/labor



110 Cup

HCU110S

Specifications:

Standard: Removable lid tank, Brewstation® base, drip tray
Controls: On/off switch
Electrical: 120V, 60 Hz, 1400W
Weight: 14.2 lbs / 6.4 kg (ship.)
Warranty: 1 year parts/labor



HCU045S-CE

Electrical: 220-240 V, 50/60 Hz, 1280-1525 W
Warranty: 1 year parts/labor



HCU065S-CE

Electrical: 220-240 V, 50/60 Hz, 1280-1525 W
Warranty: 1 year parts/labor



HCU110S-CE

Electrical: 220-240 V, 50/60 Hz, 1280-1525 W
Warranty: 1 year parts/labor



One-hand dispensing fills cups fast to shorten the wait



12.25"

12.25"

12.25"

26.25"

21.25"

19"

OVERALL HEIGHT



Removable tank for fast and easy cleanup.

6126-650

**Tempest®/Summit®
64 oz./1.8 L
Polycarb. Container**

6126-650 comes with complete cutting assembly and cover. For HBH550 Series, HBH650 Series, HBH850 Series, HBS1200 Series (230V only) and HBS1400.



6126-600

**Tempest®/Summit®
48 oz./1.4 L
Polycarb. Container**

With complete cutting assembly and cover. For HBH550 Series, HBH650 Series and HBH850 Series.



6126-HBF600

**HBF600 64 oz./1.8 L
Polycarbonate
Container**

With complete cutting assembly and dosing cup. For HBF600 Series.



6126-1200

**Revolution®
64 oz./1.8 L
Polycarb. Container**

With complete cutting assembly and cover. For HBS1200.



**6126-250 (120V)
6126-250-CE (230V)**

**Rio®
44 oz./1.25 L
Polycarb. Container**

With complete cutting assembly and cover. For HBB250R and HBB250 Series.



**6126-450 (120V)
6126-450-CE (230V)**

**Tango®
48 oz./1.4 L
Polycarb. Container**

With complete cutting assembly and cover. For HBH450R and HBH450 Series.



**6126-HBF500
6126-HBF500-CE (230V)**

**48 oz./1.4 L
Polycarbonate
Container**

With complete cutting assembly and dosing cup. For HBF500 Series.



6126-750

**48 oz./1.4 L
Polycarbonate
Container**

With complete cutting assembly and cover. For HBH750 Series.



Accessories

6126-1100

**HBF1100 1 Gallon/
4L Polycarbonate
Container**

With complete cutting assembly, cover and dosing cup. For HBF1100 Series.



6126-1100S

**HBF1100 1 Gallon/4L
Stainless Steel
Container**

With complete cutting assembly, cover and dosing cup. For HBF1100S Series.



**6126-250S (120V)
6126-250S-CE (230V)**

**Rio® 32 oz./ .95 L
Stainless Steel
Container**

With complete cutting assembly and cover. For HBB250SR and HBB250 Series.



**6126-400 (120V)
6126-400-CE (230V)**

**64 oz./1.8 L
Stainless Steel
Container**

For HBF500S Series.



6126-HBF600S

**64 oz./1.8 L
Stainless Steel
Container**

For HBF600S Series.



**6126-HBB909 (120V)
6126-HBB909-CE (230V)**

**909 32 oz./ .95 L
Stainless Steel
Container**

With complete cutting assembly, cover, clutch, and collar. For HBB908 Series and HBB909.



**6126-HBB908 (120V)
6126-HBB908-CE (230V)**

**908® 44 oz./1.25 L
Polycarbonate
Container**

With complete cutting assembly and cover. For HBB908 Series.



6126-755

**64 oz./2 L
Polycarbonate
Container**

With complete cutting assembly and cover. For HBH750 Series.



98908

**Multi-Blender
Repair Kit**

Complete cutting assembly, clutch, and gasket. For models 901, 908, 909, 910, 918, and 919.



98450

**Tango® Blender
Repair Kit**

With complete cutting assembly, gasket, clutch, and retainer nut. For HBH450 Series.



98250

**Rio® Blender
Repair Kit**

With complete cutting assembly, clutch, gasket, and retainer nut. For models HBB250 and HBB250S Series.



98400

**Food Blender
Repair kit**

With complete cutting assembly, clutch, gasket, and retainer nut. For HBF500S Series.



98500

**Food Blender
Repair kit**

With complete cutting assembly, clutch, gasket, and retainer nut. For HBF500.



98650

**Tempest®/Summit®
Revolution®/Eclipse®
Repair Kit**

With complete cutting assembly, clutch, gasket, and retainer nut. For HBH650 Series, HBH750 Series, HBH850 Series, HBF600/HBF600S Series, and HBS1400.



981100

**HBF1100 Cutter
Assembly**

With complete cutting assembly, clutch, gasket, and retainer nut. For HBF1100 Series.



981100S

**HBF1100S Cutter
Assembly**

With complete cutting assembly, clutch, gasket, and retainer nut. For HBF1100S Series.



WK2000

Wheel Kit for COT2000

Contains four swivel wheels. Fits COT2000.



TRK2000

Tank Regulator Kit for COT2000

Regulator and air hose for connection to CO2 tank. For use with COT2000.



QS850

Quiet Shield® Sound Enclosure

Reduces sound during operation. Maintains low profile height even when open. Fits HBH850 Series.



CK650

Tempest® In-Counter Kit

Allows HBH650 Series to be mounted in-counter. Kit includes stainless steel bracket, gasket, hardware & counter cutting template.



929

Stainless Steel Agitator

For easy mixing of hard ice cream shakes or mix-ins. For models 94950, HMD900, HMD200 and HMD400.



930

Stainless Steel Agitator

For faster mixing of hard ice cream shakes or mix-ins. For 94950 and HMD900 Series.



96000

Foot Pedal

Can be used with Mix 'n Chill® model 94950 for hands-free control of mixer.



JP750

Jar Pad for 6126-750 Container

Converts your existing blender which uses a 64oz container to the Eclipse™ 48oz container for smaller batch sizes. Allow 6129-750 Eclipse™ container to be used on Fury™ HBH550, Tempest® HBH650 and Summit® HBH850 series blenders.



HMIA200B

Immersion Mixer Chopping Attachment

For mixing, chopping & pureeing soups, sauces, batters & dressings in bowls or in the pan. Autoclavable for quick sterilization.



928

Plastic Cone Agitator

Gently mixes pre-ground candies, cookies, and fruit flavors into milkshakes. For models 94950, HMD200, HMD400 and HMD900 Series.



110E

Universal Stainless Steel Container

32 oz./.95 L stainless steel container for all drink mixers by Hamilton Beach Commercial.



**990156300 (120V)
990156400 (230V)**

Replacement Motor Kit

For drink mixer HMD200 Series and HMD400 Series.



DMC2000

2.5 Gallon Plastic Container

Plastic drink mix container for custom mixes. For COT2000.



Global Warranty Coverage



Hamilton Beach® Commercial stands behind its global platform of products worldwide. We understand that your foodservice equipment is a crucial element to the profitability of your business. If you ever have an issue, you need service that is quick, convenient and dependable.

FOR OUR U.S. CUSTOMERS:



For qualifying products, please follow this easy 3 step process:

1. Dial 1-866-285-1087 to speak to a member of our highly trained technical services staff (M-F 8am-5pm EST). We will make an initial phone diagnosis.
2. If it is determined that minimal on-site maintenance cannot be performed, Hamilton Beach® Commercial will ship a replacement product to your location.
3. Once the replacement unit is received, you send the troubled unit back to Hamilton Beach® Commercial (we will provide the box and supporting materials to return the unit and we pay the freight cost for the returned unit).

For all other products, please call 1-866-285-1087 to receive assistance on your parts and labor warranty.

Note: Limitations and exclusions apply. See operation manual for complete details. Express Care is only available to end users located in the continental US, Alaska and Hawaii.

FOR OUR GLOBAL CUSTOMERS:



Hamilton Beach® Commercial has a network of highly trained service companies in over 60 countries worldwide.

We provide 24/7/365 support via our dedicated technical services website which includes:

- detailed troubleshooting and repair instructions
- drawings with exploded view
- recommended parts lists
- registered service centers by country
- operation manuals and agency certifications

Our technical services team, based in North Carolina USA, offers a variety of training options, including web-based training.

Please visit us at:
hamiltonbeach.commercial.com to find your country service provider, or contact us directly at +1 910 693 4277 or send an email to:
commercial.support@hamiltonbeach.com.



4421 Waterfront Drive • Glen Allen, Virginia 23060 • 1-800-572-3331 (US) or + 1-910-963-4277
www.hamiltonbeachcommercial.com

©2016 Hamilton Beach Brands, Inc. • Printed in the USA • BB 4/16 1021-0416-COM