



STORAGE & TRANSPORT



WORKING SOLUTIONS



FOCUS  
FOODSERVICE

JOHNSON-ROSE

CALL: 800.968.3918  
FAX: 800.968.4129  
orders@crown-brands.com  
www.crown-brands.com

# The Single Source **②** Solutions

As part of the Crown Brands' initiative to create a better / best tiered product structure in our storage and transportation line, we offer our customers items under both our Focus Foodservice and Johnson-Rose brands. Combined, we have over 2,000 products to choose from. Our selection of shelving and wall storage solutions is extensive in materials, styles and price points. When your build requires materials "to spec", Focus Foodservice delivers every time. If a value to quality proposition is needed, our Johnson-Rose brand is a cost effective solution.



FBC2819B



**FOCUS**  
FOODSERVICE

## Get Focused on Efficient Use of Space with our NEW Folding Bus Cart or Wall Storage Systems.

Our new 3-Shelf Bus Cart will make light of most any chore and when you done. Its easy to use and easier to store when not in use. [pages 24 and 37].

Finding enough storage is always a challenge. Take advantage of every inch of accessible wall space available with our wall mount shelving supplies, kits, pot and pan racks and our EZ-Wall Storage System. We have over 100 components and accessories in green epoxy, stainless steel and chromate to customize just about any vertical space [pages 38-47].



## Worktables & Equipment Stands that Provide Stainless Service.



Our Johnson-Rose table selection has over 300 skus available in stainless or stainless and galvanized combinations. They are extremely well designed and constructed to handle the daily demands of a commercial kitchen. Each worktable features riveted hat channels, plus rolled and welded edges for performance and durability (see pages 68-69).

# Table of Contents [by Brand]

## Focus Foodservice: 04 - 58

### Shelving Introduction.....02 - 04

- Corner Shelves.....04-05
- Stainless Steel Shelves...06-07
- FPS-Plus™ Shelves.....08-10
- FPS-Plus™ Accessories\* .....11
- Green Epoxy Shelves.....12
- Green Epoxy Accessories\* ...13
- Black Epoxy Shelves.....14
- Black Epoxy Accessories\*.15
- Chromate Shelves.....16-18
- Chromate Accessories\* .....19
- Heavy-Duty Dunnage.....20
- Dunnage Racks.....21-23
- Shelf Cart Kits.....23

### Solutions Introduction.....24

- Security Cages.....25-29
- Enclosure Panels.....30-31
- HDS-PLUS™ High Density..32-35
- Z-Racks & Welded Racks...36
- Sheet Pan Rack, Cover,  
Dish Rack Dolly and  
 3-Shelf Folding Bus Cart...37

### Wall Storage Introduction.....38

- EZ-WALL System.....39-41
- EZ-WALL Accessories.....42
- EZ-WALL Kit.....43
- Pot Rack & Utensil Rack.....44
- KD Shelving Kits.....45
- Direct Wall Mounts.....46
- Wall Mounted Shelving.....47

### Accessories Introduction.....48

- Shelving and Post  
Accessories\* .....49-53
- Casters.....54-57

## Making Your Search...Simple.

As we continue to evaluate and strategize our brands' product assortments, we want to make it easy for our customers to find what they need quickly.

To help navigate through over 3,000 storage and transportation items, we have organized our catalog by brand then by segment.

Still need assistance? Please contact our customer service or visit our websites through [www.crown-brands.com](http://www.crown-brands.com).

## Johnson-Rose: 59 - 73

### Shelving + Accessories.....60 - 63

- Green Epoxy Shelves.....61
- Chrome Shelves.....62
- Shelving Kits.....63
- Security Cages.....63

### Solutions.....64

- Dunnage Racks.....64
- K/D Bun Racks + Covers.....64
- Hand Sinks.....64

### Wall Storage Options.....65

- K/D Stainless Steel Shelves..65
- Microwave Shelves.....65
- Wall Mount Brackets.....65

### Shelf + Post Accessories.....66

- Accessories.....66
- Casters.....66

### Worktables, Stands + Operational Table Tops and Base.....67 - 73

- Stainless Steel Worktables.....68
- Overshelves for Worktables.....69
- Equipment Stands.....69
- Operational Tables Chart.....70
- Operational Tables.....71-73

## Shared Resources: + Index 74 - 77

- Shelving Introduction.....02
- Two Brands, More Options.....59
- Index By Brand.....74-77

# More Ways to Store



We support our customers by offering the largest selection of sizes and comprehensive assortment of shelving styles and finishes in the industry. Our Focus Foodservice shelves and posts are manufactured to the highest quality specifications, while our Johnson-Rose branded shelving adds a more economical alternative to our line.

Focus Foodservice: Shelving					
Shelf Size	Chromate Finish	Black Epoxy Coated	Green Epoxy Coated	FPS - PLUS (Solid /Vented)	Stainless Steel Wire Solid
12" x 36"	X		X		
12" x 48"	X		X		
12" x 60"	X		X		
14" x 24"	X	X	X		
14" x 30"	X	X	X		X
14" x 36"	X	X	X		X
14" x 42"	X	X	X		
14" x 48"	X	X	X		X
14" x 60"	X	X	X		X
14" x 72"	X	X	X		
18" x 18"	X				
18" x 24"	X	X	X	X	X
18" x 30"	X	X	X	X	X
18" x 36"	X	X	X	X	X
18" x 42"	X	X	X	X	X
18" x 48"	X	X	X	X	X
18" x 54"	X	X	X	X	
18" x 60"	X	X	X	X	X
18" x 72"	X	X	X	X	X
21" x 24"	X		X	X	
21" x 30"	X		X	X	
21" x 36"	X		X	X	
21" x 42"	X		X	X	
21" x 48"	X		X	X	
21" x 54"	X		X	X	
21" x 60"	X		X	X	
21" x 72"	X		X	X	
24" x 24"	X	X	X	X	X
24" x 30"	X	X	X	X	X
24" x 36"	X	X	X	X	X
24" x 42"	X	X	X	X	X
24" x 48"	X	X	X	X	X
24" x 54"	X	X	X	X	
24" x 60"	X	X	X	X	X
24" x 72"	X	X	X	X	
30" x 36"	X				
30" x 60"	X		X		
36" x 48"	X		X		
36" x 60"	X		X		
36" x 72"	X		X		

Johnson-Rose: Shelving		
Shelf Size	Chromate Finish	Green Epoxy Coated
14" x 24"	X	X
14" x 30"	X	X
14" x 36"	X	X
14" x 42"	X	X
14" x 48"	X	X
14" x 60"	X	X
14" x 72"	X	X
18" x 18"	X	
18" x 24"	X	X
18" x 30"	X	X
18" x 36"	X	X
18" x 42"	X	X
18" x 48"	X	X
18" x 54"	X	X
18" x 60"	X	X
18" x 72"	X	X
21" x 24"	X	X
21" x 30"	X	X
21" x 36"	X	X
21" x 42"	X	X
21" x 48"	X	X
21" x 54"	X	X
21" x 60"	X	X
21" x 72"	X	X
24" x 24"	X	X
24" x 30"	X	X
24" x 36"	X	X
24" x 42"	X	X
24" x 48"	X	X
24" x 54"	X	X
24" x 60"	X	X
24" x 72"	X	X

\* NOTE: This list does not include any specialty shelving such as wine, corner or heavy-duty dunnage shelves.



**FOODSERVICE**

SHELVING: 02-23

## SHELVING 101:

There's a place for everything and everything has its place. But without the best storage solution, everything will eventually become one thing... **DISORGANIZED.**

Focus Foodservice understands that although everything has a place, the place is not exactly the same for everything.

Front of the house to back, from prep to freezer to above the sink. You need something to help store your "everything".

You need shelving to stack on. Ways to divide and conquer your places and spaces.

We've got you covered.



**FOCUS FOODSERVICE**

Call: 800.968.3918

Fax: 800.968.4129

Click: [orders@crowns-brands.com](mailto:orders@crowns-brands.com)

Search: [www.focusfoodservice.com](http://www.focusfoodservice.com)

# Wire Corner Shelving [Chromate & Green Epoxy]

## How to Corner the Market

Cornered by the lack of storage space?  
Focus Foodservice Corner Shelves Can Help.

- Maximize storage by utilizing the entire space
- Great for organizing areas around 3 compartment sinks
- Finish off corner runs in coolers
- 650 lbs per shelf capacity
- Available in Green Epoxy & Chrome
- 18", 21", and 24" options
- Dimension of shelf is determined by sides perpendicular to two the walls

*Please note: When ordering corner shelves, you must order a total of 5 posts.*



step 1: install corner shelving



step 2: add additional units



step 3: complete the perimeter

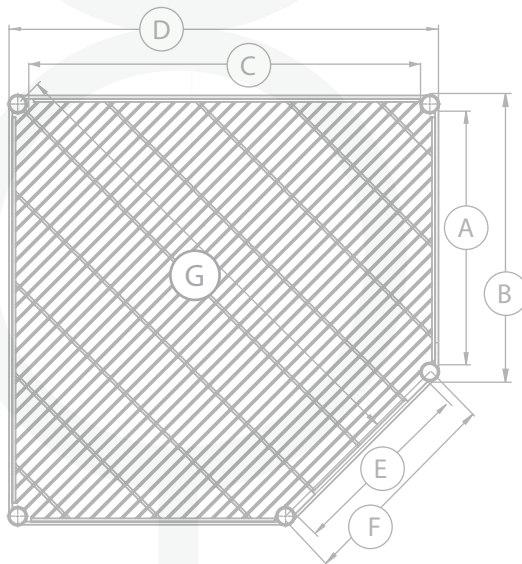

## Determining the Corner Shelf Dimensions

Shelf Size	A	B	C	D	E	F	G
18" Shelf	15.53" (394mm)	18" (457mm)	26.14" (663mm)	28.55" (725mm)	13.85" (352mm)	16.26" (413mm)	31.09" (789mm)
21" Shelf	18.63" (394mm)	21" (533mm)	29.29" (743mm)	31.55" (801mm)	13.85" (352mm)	16.26" (413mm)	35.33" (897mm)
24" Shelf	21.64" (549mm)	24" (609mm)	32.24" (818mm)	34.55" (877mm)	13.85" (352mm)	16.26" (413mm)	39.58" (1005mm)



**NSF APPROVED:** These commercial rated shelves are available in chromate and green epoxy. Green epoxy coated shelves are ideal for any type of storage application, dry or wet. Chromate is only recommended for dry storage opportunities.

## Wire Corner Shelves [Chromate and Green Epoxy Coated]

Chromate Item #	Green Epoxy Item #	Description	Case
FF18CC	FF18CG	18" (45.7mm) Corner Shelf	4
FF21CC	FF21CG	21" (53.0mm) Corner Shelf	4
FF24CC	FF24CG	24" (61.0 mm) Corner Shelf	4

# Wire Corner Shelving Accessories



**CROWN BRANDS**  
STORAGE AND  
TRANSPORTATION



FPSL24CL inlay on FF24GC shelf

## Clear Shelf Inlays for Corner Shelves

Clear plastic mats provide greater stability for items on shelves, while allowing for better visibility and light to pass through. Designed to fit corner shelves. Available in all three corner shelf sizes.

Item #	Description	Case
FPSL18CL	Clear inlay for 18" (45.7mm) shelf	4
FPSL21CL	Clear inlay for 21" (53.0mm) shelf	4
FPSL24CL	Clear inlay for 24" (60.0mm) shelf	4

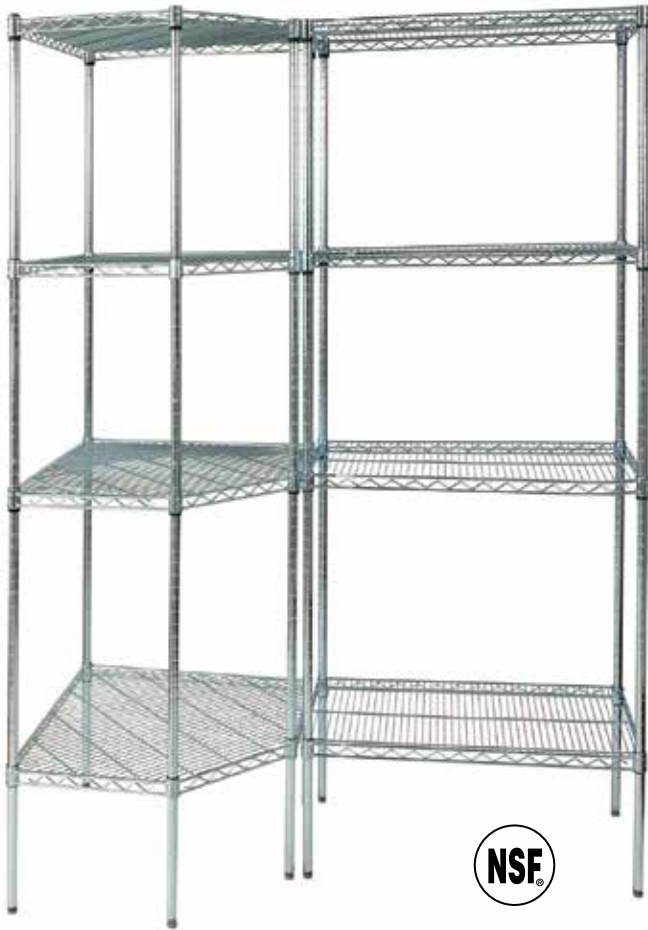

## Corner Shelves Can Also Hold Their Own Just Standing Alone.

Need to find a little more storage space in the corner of an already full room or have that underutilized space next to a 3-compartment sink?

These corner shelf units can solve many of those "what to do" situations that standard shelving just cannot accommodate.



## U-Clamps: Reduce Number of Posts, Increase Economy of Shelf Space.

The FPSSH clamps that were developed for our FPS-Plus shelves work on corner shelving as well. Since the corner shelves are reinforced with a second wire around their perimeter, a standard S hook will not accommodate the extra width. The U-clamp design allows you to hook over the dual wires on the corner shelf as well as the single wire on the adjacent shelving unit.

- Connect shelves while eliminating posts, saving space and money.
- Each shelf assembled with U-Clamps will hold up to 450 weight capacity
- Easy to assemble and adjust



## Corner + Standard Shelves = Maximum Capacity

Per the diagram on page 4, the dimensions of a shelf are based on the measurement of the two shorter parallel sides of the shelf (B). This measurement is the same on any of our (and most other) standard 4-sided shelves. This makes it extremely easy to maximize storage in almost any room - corner to corner. Plus, corner shelves allow you to reach stored items from the front quickly instead of having a post obstructing your access point.

Item #	Description	Case
FPSSH	Stainless Steel U Clamps to attach adjacent shelving units (2 per pack)	96

# Solid Stainless Steel Shelving

**NSF** **NSF APPROVED:** These commercial rated solid and wire stainless steel shelves are ideal for any storage application, dry or wet.

**1 YR** **1 YEAR LIMITED WARRANTY:** Focus Foodservice offers a one year limited warranty on our stainless steel shelves against rust or corrosion under general conditional usage.



## Stainless Performance

- Marine edge contains spills.
- Solid shelf great to use as top of a worktable.
- Die-cast corners add increased strength to the overall construction.
- Each shelf up to 48" in length is rated to support up to 800 lbs. of uniformly distributed weight. Shelves longer than 48" support 600 lbs.



Die-cast corners with heavy-duty bolt construction.

Stainless steel posts available in 63", 74" and 86" lengths in both stationary and mobile options (see page 7).



## Solid Stainless Steel Shelves

Item #	Shelf Size (width x length)		Case
	(in.)	(cm)	
FF1430SSS	14" x 30"	35.5 x 76.0	1
FF1436SSS	14" x 36"	35.5 x 91.4	1
FF1448SSS	14" x 48"	35.5 x 122.0	1
FF1460SSS	14" x 60"	35.5 x 152.4	1
FF1824SSS	18" x 24"	45.7 x 61.0	1
FF1830SSS	18" x 30"	45.7 x 76.0	1
FF1836SSS	18" x 36"	45.7 x 91.4	1
FF1842SSS	18" x 42"	45.7 x 106.6	1
FF1848SSS	18" x 48"	45.7 x 122.0	1
FF1860SSS	18" x 60"	45.7 x 152.4	1
FF2424SSS	24" x 24"	61.0 x 61.0	1
FF2430SSS	24" x 30"	61.0 x 76.0	1
FF2436SSS	24" x 36"	61.0 x 91.4	1
FF2442SSS	24" x 42"	61.0 x 106.6	1
FF2448SSS	24" x 48"	61.0 x 122.0	1
FF2460SSS	24" x 60"	61.0 x 152.4	1



# Stainless Steel Wire Shelving Posts and Select Accessories



**CROWN BRANDS**  
STORAGE AND  
TRANSPORTATION

## Baskets & Hooks

The intergated hooks on these baskets wrap around the outer truss wires on most standard shelves\*.

- Available in 3 sizes, in both chromate and green epoxy finishes.

\* Cannot be used on corner shelves. hooks will not wrap around their double wire truss construction.



More accessories on page 52-53



FWMHOOKSS [single] and  
FWMHOOKSS2PK3 [double]

Single J Hooks are packed 12 per package. Double J Hooks are packed 3 per package.



FURHOOKS

These 2 3/4" Stainless steel hooks included with our utensil rack for standard-duty storage. They are also sold separately. Packed 20 per package.

- The open wire design minimizes dust accumulation and allows a free circulation of air, greater visibility of stored items.
- These commercial rated stainless shelves are ideal for any storage application, dry or wet.

FF1836WRSS

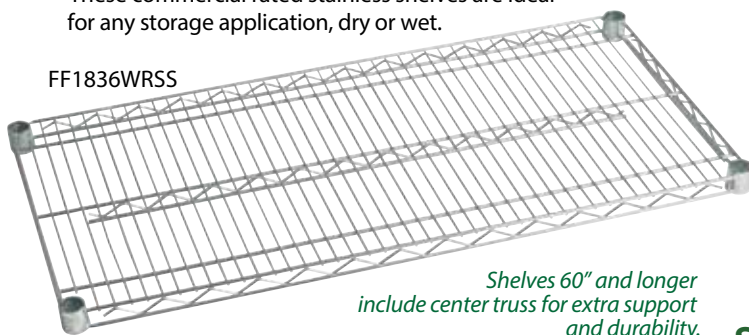

*Shelves 60" and longer include center truss for extra support and durability.*

## Stainless Steel Wire Shelves

Item #	Shelf Size (width x length)		Case
	(in.)	(cm)	
FF1836WRSS	18" x 36"	45.7 x 91.4	4
FF1848WRSS	18" x 48"	45.7 x 122.0	4
FF1860WRSS	18" x 60"	45.7 x 152.4	2
FF2436WRSS	24" x 36"	61.0 x 91.4	4
FF2448WRSS	24" x 48"	61.0 x 122.0	4
FF2460WRSS	24" x 60"	61.0 x 152.4	2



*Zinc plated feet allow you to keep shelving unit level on uneven floors.*

## Stainless Steel Posts

Posts available in either stationary or mobile options, please specify required post when placing order. Converting stationary posts to mobile after purchase is as an option. The leveling feet can be replaced with thread casters or for greater durability, remove and replace the entire leveling foot with stem casters.

Stationary Post Item #	Mobile Post Item #	Height		Case
		(in.)	(cm)	
FG063SS	FGN063SS	63	160.0	4
FG074SS	FGN074SS	74	188.0	4
FG086SS	FGN086SS	86	218.4	4

# FPS-PLUS™ Polymer Shelving with Anti-Microbial Protection



## FPS-PLUS Shelving Solutions

FPS-PLUS™ is the next generation in storage solutions. It offers the same durability and flexibility as standard wire shelving, but with more versatility and ease of cleaning.

- All of the polymer panels, green epoxy shelf trusses and posts are infused with anti-microbial protection. Since this is incorporated into the plastic material and epoxy coating during the manufacturing process, it will not wash off or wear away. This 24/7 protection will last the useful life of the shelving.
- The removable polymer panels are designed to easily lift off the shelving trusses and conveniently fit into most commercial dishwashers.
- Available in 18", 21" and 24" depths and in all standard lengths from 24"-72".
- Each shelf up to 48" in length is rated to support up to 800 lbs. of uniformly distributed weight. Shelves longer than 48" support up to 600 lbs.



Shelving panels remove for easy cleaning and fit into most standard commercial dishwashers.

Routine cleaning is easier and more convenient than ever. Complete shelving units no longer need to be disassembled or moved. Simply detach panels, wash and re-attach.



Shelving panels available in both solid and vented styles in numerous sizes.



**NSF APPROVED:** These commercial rated polymer panels and green epoxy trusses are ideal for any storage application, dry or wet. Panels are easy to remove and clean without the need to move or disassemble the shelving unit.



**LIFETIME / LIMITED WARRANTY:** We offer a lifetime warranty against rust or corrosion on our FPS-PLUS™ Polymer panels. A 12-year warranty covers our green epoxy shelf trusses and posts against rust or corrosion or manufacturer's defect when used under general conditions.



**CROWN BRANDS**  
**STORAGE AND TRANSPORTATION**

## FPS-PLUS™ Polymer Shelves

with Anti-Microbial Protection

Need a storage system that is easier to clean and offers the same flexibility & durability of standard wire shelving? FPS-PLUS™ is the answer.

Vented Shelf Item #	Solid Shelf Item #	Shelf Size (width x length)		Case
		(in.)	(cm)	
FPS1824VNGN	FPS1824SOGN	18" x 24"	45.7 x 61.0	4
FPS1830VNGN	FPS1830SOGN	18" x 30"	45.7 x 76.0	4
FPS1836VNGN	FPS1836SOGN	18" x 36"	45.7 x 91.4	4
FPS1842VNGN	FPS1842SOGN	18" x 42"	45.7 x 106.6	4
FPS1848VNGN	FPS1848SOGN	18" x 48"	45.7 x 122.0	4
FPS1854VNGN	FPS1854SOGN	18" x 54"	45.7 x 137.0	4
FPS1860VNGN	FPS1860SOGN	18" x 60"	45.7 x 152.4	2
FPS1872VNGN	FPS1872SOGN	18" x 72"	45.7 x 182.9	2
FPS2124VNGN	FPS2124SOGN	21" x 24"	53.0 x 61.0	4
FPS2130VNGN	FPS2130SOGN	21" x 30"	53.0 x 76.0	4
FPS2136VNGN	FPS2136SOGN	21" x 36"	53.0 x 91.4	4
FPS2142VNGN	FPS2142SOGN	21" x 42"	53.0 x 106.6	4
FPS2148VNGN	FPS2148SOGN	21" x 48"	53.0 x 122.0	4
FPS2154VNGN	FPS2154SOGN	21" x 54"	53.0 x 137.0	4
FPS2160VNGN	FPS2160SOGN	21" x 60"	53.0 x 152.4	2
FPS2172VNGN	FPS2172SOGN	21" x 72"	53.0 x 182.9	2
FPS2424VNGN	FPS2424SOGN	24" x 24"	61.0 x 61.0	4
FPS2430VNGN	FPS2430SOGN	24" x 30"	61.0 x 76.0	4
FPS2436VNGN	FPS2436SOGN	24" x 36"	61.0 x 91.4	4
FPS2442VNGN	FPS2442SOGN	24" x 42"	61.0 x 106.6	4
FPS2448VNGN	FPS2448SOGN	24" x 48"	61.0 x 122.0	4
FPS2454VNGN	FPS2454SOGN	24" x 54"	61.0 x 137.0	4
FPS2460VNGN	FPS2460SOGN	24" x 60"	61.0 x 152.4	2
FPS2472VNGN	FPS2472SOGN	24" x 72"	61.0 x 182.9	2



*Make sure to specify mobile posts [below] and casters at time of order if you are building a shelving cart.*

*FPS-PLUS™ Shelves work with our standard green epoxy posts, so there are no special posts to purchase.*

## Green Epoxy Posts

No special posts to purchase. FPS-PLUS™ Polymer Shelving works best with standard Focus Foodservice green epoxy posts. Our posts carry a 12-year limited warranty. Make sure to specify posts for stationary or mobile use at time of order.

Stationary Post Item #	Mobile Post Item #	Height		Case
		(in.)	(cm)	
FG007G	FGN007G	7	17.8	4
FG013G	FGN013G	13	33.0	4
FG033G	FGN033G	33	83.8	4
FG054G	FGN054G	54	137.2	4
FG063G	FGN063G	63	160.0	4
FG074G	FGN074G	74	188.0	4
FG086G	FGN086G	86	218.4	4



# FPS-PLUS™ Polymer Shelving

## Mobile Carts and Replacement Parts

### Mobile Cart Kits Available in 4 or 5 Vented Shelf Units

- 4 or 5 shelves in widths of 18", 21" or 24" and lengths of 36", 48" or 60".
- A set of 4 each 5" (12.7 cm) polyurethane swivel casters. (2 with brakes) and a set of 4 bumpers.
- A set of 4 green epoxy 63" mobile posts.
- Overall weight capacity per cart is 1000 lbs (455 kg).

#### 4 Shelf Models

Item #	Shelf Size (width x length)		Case
	(in.)	(cm)	
FMPS1836694	18" x 36"	45.7 x 91.4	1
FMPS1848694	18" x 48"	45.7 x 122.0	1
FMPS1860694	18" x 60"	45.7 x 152.4	1
FMPS2136694	21" x 36"	53.0 x 91.4	1
FMPS2148694	21" x 48"	53.0 x 122.0	1
FMPS2160694	21" x 60"	53.0 x 152.4	1
FMPS2436694	24" x 36"	61.0 x 91.4	1
FMPS2448694	24" x 48"	61.0 x 122.0	1
FMPS2460694	24" x 60"	61.0 x 152.4	1

#### 5 Shelf Models

Item #	Shelf Size (width x length)		Case
	(in.)	(cm)	
FMPS1836695	18" x 36"	45.7 x 91.4	1
FMPS1848695	18" x 48"	45.7 x 122.0	1
FMPS1860695	18" x 60"	45.7 x 152.4	1
FMPS2136695	21" x 36"	53.0 x 91.4	1
FMPS2148695	21" x 48"	53.0 x 122.0	1
FMPS2160695	21" x 60"	53.0 x 152.4	1
FMPS2436695	24" x 36"	61.0 x 91.4	1
FMPS2448695	24" x 48"	61.0 x 122.0	1
FMPS2460695	24" x 60"	61.0 x 152.4	1



Vented Shelf Kits

### Replacement Panels use as back-up during cleaning or as alternates for greater versatility.

Vented Panel Item #	Solid Panel Item #	Panel Description	Shelf Size (width/length)		Case
			(in.)	(cm)	
FPS1812VPEGN	FPS1812SOPEGN	18" x 12" End Panel	18" x 12"	45.7 x 30.4	12
FPS1812VPMGN	FPS1812SOPMGN	18" x 12" Middle Panel	18" x 12"	45.7 x 30.4	12
FPS1818VPEGN	FPS1818SOPEGN	18" x 18" End Panel	18" x 18"	45.7 x 45.7	12
FPS2112VPEGN	FPS2112SOPEGN	21" x 12" End Panel	21" x 12"	53.0 x 30.4	12
FPS2112VPMGN	FPS2112SOPMGN	21" x 12" Middle Panel	21" x 12"	53.0 x 30.4	12
FPS2118VPEGN	FPS2118SOPEGN	21" x 18" End Panel	21" x 18"	53.0 x 45.7	12
FPS2412VPEGN	FPS2412SOPEGN	24" x 12" End Panel	24" x 12"	60.9 x 30.4	12
FPS2412VPMGN	FPS2412SOPMGN	24" x 12" Middle Panel	24" x 12"	60.9 x 30.4	12
FPS2418VPEGN	FPS2418SOPEGN	24" x 18" End Panel	24" x 18"	60.9 x 45.7	12



FPS2418VPEGN



FPS1812OPEGN

# Accessorize Your FPS-PLUS™ Shelving



**CROWN BRANDS**  
STORAGE AND  
TRANSPORTATION

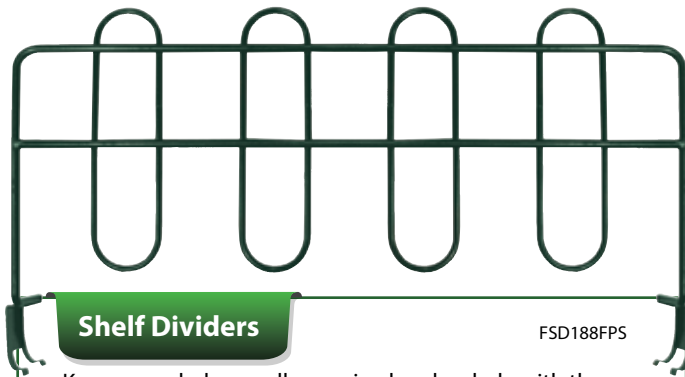

## Shelf Dividers

FSD188FPS

Keep your shelves well organized and orderly with these 8" high dividers. Order by shelf depth for either 18" or 24". Shelf divider brackets fit securely over FPS-Plus™ shelf panels and can be easily removed when shelves need to be cleaned.

Specially designed C brackets accommodate the width and contour of our FPS-Plus™ shelf panels.

## Post Clamps

FPSPC

Secure two units together for maximum strength. Green epoxy coated post clamps are constructed slightly wider apart to accommodate the gap between two FPS-PLUS™ Polymer shelving units.



## "U" Shelf Clamps

FPSSH



Save time, space and money by using our "U" Clamp shelf connectors when multiple shelving units are required. These stainless steel connectors will combine shelving units in a variety of configurations, while eliminating the need for adjacent posts.

Assembly is quick and easy - no tools required. Remove the FPS-Plus™ shelving panels from your assembled unit, attach the "U" clamps to the shelving trusses and re-attached the panels. These clamps will accommodate the thickness of the polymer shelf panels with a friction fit.



Affix "U" Clamps to truss.



Secure second truss.



Snap on first panel.



Attach all panels.

## FPS-PLUS™ Accessories

Item #	Description	Case
FSD188FPS	Shelf Divider 18" x 8" h (53.0 x 20.3 cm)	4
FSD248FPS	Shelf Divider 24" x 8" h (61.0 x 20.3 cm)	4
FSL184FPS	Side Shelf Ledge 18" X 4" h (45.7 x 10.1 cm)	4
FSL214FPS	Side Shelf Ledge 21" X 4" h (53.0 x 10.1 cm)	4
FSL244FPS	Side Shelf Ledge 24" x 4" h (61.0 x 10.1 cm)	4
FBL304FPS	Back Shelf Ledge 30" x 4" h (76.2 x 10.1 cm)	4
FBL364FPS	Back Shelf Ledge 36" x 4" h (91.4 x 10.1 cm)	4
FBL484FPS	Back Shelf Ledge 48" x 4" h (121.9 x 10.1 cm)	4
FPSSH	"U" Clamps, Stainless Steel (2 per pack)	96
FPSPC	Post clamps, green epoxy coated (2 per pack)	25

\* More shelving accessories available. Refer to pages 49-53 for more products.

## Shelf Ledges

Shelf ledges promote safety in your operation by keeping items from or falling off shelves. End and side ledges available and can be used in tandem for complete post-to-post containment.

All ledges are 4" high. Side ledges are available in 18", 21" and 24" depths; back ledges are available in 30", 36", 48" and 60" lengths.

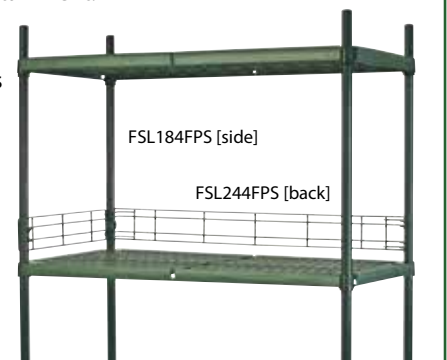

FSL184FPS [side]

FSL244FPS [back]

# Green Epoxy Shelving & Posts



**NSF APPROVED:** These commercial rated green epoxy coated shelves, posts are ideal for any storage application, dry or wet.



**LIMITED WARRANTY:** We offer a 12-year warranty covers our green epoxy shelves and posts against rust or corrosion or manufacturer's defect when used under general conditions.

## Green Epoxy Coated Shelves

These zinc underplated commercial rated steel wire shelves with an optimum thickness of green epoxy to ensure long lasting performance, even in the toughest wet environments.

Shelf Size (width x length)

Item #	(in.)	(cm)	Case
FF1236GN	12" x 36"	30.5 x 91.4	4
FF1248GN	12" x 48"	30.5 x 122.0	4
FF1260GN	12" x 60"	30.5 x 152.4	2
FF1424G	14" x 24"	35.5 x 61.0	4
FF1430G	14" x 30"	35.5 x 76.0	4
FF1436G	14" x 36"	35.5 x 91.4	4
FF1442G	14" x 42"	35.5 x 106.6	4
FF1448G	14" x 48"	35.5 x 122.0	4
FF1460G	14" x 60"	35.5 x 152.4	2
FF1472G	14" x 72"	35.5 x 182.9	2
FF1824G	18" x 24"	45.7 x 61.0	4
FF1830G	18" x 30"	45.7 x 76.0	4
FF1836G	18" x 36"	45.7 x 91.4	4
FF1842G	18" x 42"	45.7 x 106.6	4
FF1848G	18" x 48"	45.7 x 122.0	4
FF1854G	18" x 54"	45.7 x 137.0	2
FF1860G	18" x 60"	45.7 x 152.4	2
FF1872G	18" x 72"	45.7 x 182.9	2
FF2124G	21" x 24"	53.0 x 61.0	4
FF2130G	21" x 30"	53.0 x 76.0	4
FF2136G	21" x 36"	53.0 x 91.4	4
FF2142G	21" x 42"	53.0 x 106.6	4
FF2148G	21" x 48"	53.0 x 122.0	4
FF2154G	21" x 54"	53.0 x 137.0	2
FF2160G	21" x 60"	53.0 x 152.4	2
FF2172G	21" x 72"	53.0 x 182.9	2
FF2424G	24" x 24"	61.0 x 61.0	4
FF2430G	24" x 30"	61.0 x 76.0	4
FF2436G	24" x 36"	61.0 x 91.4	4
FF2442G	24" x 42"	61.0 x 106.6	4
FF2448G	24" x 48"	61.0 x 122.0	4
FF2454G	24" x 54"	61.0 x 137.0	2
FF2460G	24" x 60"	61.0 x 152.4	2
FF2472G	24" x 72"	61.0 x 182.9	2
FF3060GN	30" x 60"	76.0 x 152.4	2
FF3648GN	36" x 48"	91.4 x 122.0	2
FF3660GN	36" x 60"	91.4 x 152.4	2
FF3672GN	36" x 72"	91.4 x 182.9	2

## Shelving Kits

One complete shelving unit in a single box.

*Each kit contains:  
4 shelves with split sleeves  
and 4 each 74" stationary  
split posts shipped in  
white corrugated box  
with a full color label.*



Item #	Description	Case
FK183674GN	Kit includes 4 each 18" x 36" (45.7 x 91.4 cm) shelves & 4 each 74" (188.0 cm) split posts	1
FK184874GN	Kit includes 4 each 18" x 48" (45.7 x 122.0 cm) shelves & 4 each 74" (188.0 cm) split posts	1
FK243674GN	Kit includes 4 each 24" x 36" (61.0 x 91.4 cm) shelves & 4 each 74" (188.0 cm) split posts	1
FK244874GN	Kit includes 4 each 24" x 48" (61.0 x 122.0 cm) shelves & 4 each 74" (188.0 cm) split posts	1

## Green Epoxy Coated Posts

Please specify either stationary [with leveling feet] or mobile post design when ordering.

Stationary Post Item #	Mobile Post Item #	Height		Case
		(in.)	(cm)	
FG007G	FGN007G	7	17.8	4
FG013G	FGN013G	13	33.0	4
FG033G	FGN033G	33	83.8	4
FG054G	FGN054G	54	137.2	4
FG063G	FGN063G	63	160.0	4
FG074G	FGN074G	74	188.0	4
FG086G	FGN086G	86	218.4	4

# Make the Most of Your Green Shelves and Posts.



**CROWN BRANDS**  
STORAGE AND TRANSPORTATION

## Drying Rack Shelves

The first of their kind in the foodservice industry – full shelf drying racks. The perfect product for holding almost any kind of tray for drying or storage. No need for additional attachments, these are complete shelves!

Two shelf styles available:

15 drying slots to accommodate deeper bakeware and cutting boards  
35 drying slots for standard sheet pans, shallow pans, etc.

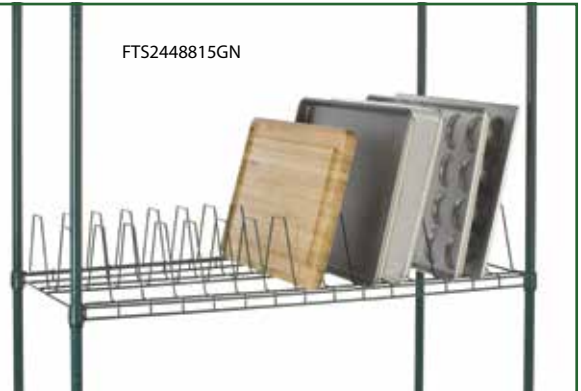

## Shelf Ledges

Shelf ledges promote safety in your operation by keeping items from or falling off shelves. End and side ledges available and can be used in tandem for complete post-to-post containment.

All ledges are 4" high. Side ledges are available in 18", 21" and 24" depths; back ledges are available in 30", 36", 48" and 60" lengths.

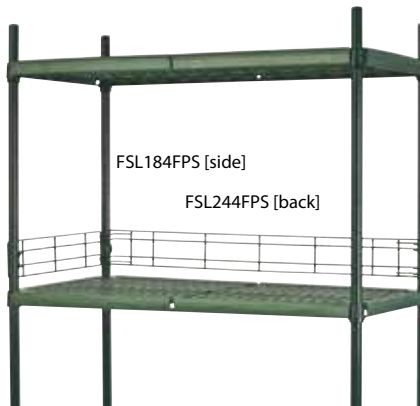

## Shelf Connecting S Hooks

Use to eliminate 2 posts per adjacent unit. Two hooks required per shelf. Available in green epoxy coated, black epoxy coated or chromate finish. Packed 2 per package



93333GN

## Post Clamps

Secure shelving units together for maximum strength. It is recommended to use clamps at the front and back of the unit. Also available in chromate and black epoxy.



FPSPC

## Universal Security Wall Brackets

Brackets provide the opportunity to secure a unit to the wall for greater safety and security. Spacing is 2" (5.1 cm) off wall. Also available in chromate.



FWPSBG

## Green Epoxy Accessories

Item #	Description	Case
FTS2448815GN	Drying Rack 24" x 48" (61.0 x 122.0 cm), 15 slots	2
FTS2448835GN	Drying Rack 24" x 48" (61.0 x 122.0 cm), 35 slots	2
FSL184FPS	Side Shelf Ledge 18" X 4" h (45.7 x 10.1 cm)	4
FSL214FPS	Side Shelf Ledge 21" X 4" h (53.0 x 10.1 cm)	4
FSL244FPS	Side Shelf Ledge 24" x 4" h (61.0 x 10.1 cm)	4
FBL304FPS	Back Shelf Ledge 30" x 4" h (76.2 x 10.1 cm)	4
FBL364FPS	Back Shelf Ledge 36" x 4" h (91.4 x 10.1 cm)	4
FBL484FPS	Back Shelf Ledge 48" x 4" h (121.9 x 10.1 cm)	4
93333GN	S Hook, shelf connector - green epoxy (2 per pack)	50
FPSPC	Post clamps, green epoxy coated (2 per pack)	25
FWPSBG	Security Bracket, green epoxy coated (2 per pack)	24

\* More shelving accessories available. Refer to pages 49-53 for more products.

# Black Epoxy Shelves, Posts and Accessories



*Zinc plated feet allow you to keep shelving unit level on uneven floors.*

## Black Epoxy: The Best Way to Display.

Constructed of steel wire and coated with an optimum thickness of black epoxy for long lasting performance makes these shelves ideal for dry storage applications such as showrooms or front of house use.

- Assembly is quick and easy with no special tools required.
- Shelf ribs run front to back, allowing you to slide items on and off shelves smoothly.
- Shelves can be adjusted at 1" (25mm) intervals along the entire length of the post.
- Each shelf up to 48" in length is rated to support up to 800 lbs. of uniformly distributed weight. Shelves longer than 48" support 600 lbs.

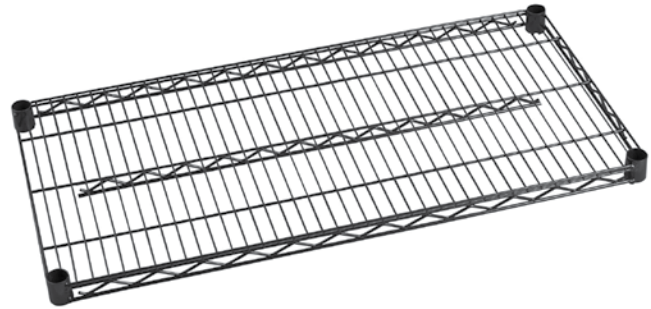

## Black Epoxy Coated Shelves

Item #	Shelf Size (width x length)		Case
	(in.)	(cm)	
FF1424BK	14" x 24"	35.5 x 61.0	4
FF1430BK	14" x 30"	35.5 x 76.0	4
FF1436BK	14" x 36"	35.5 x 91.4	4
FF1442BK	14" x 42"	35.5 x 106.6	4
FF1448BK	14" x 48"	35.5 x 122.0	4
FF1460BK	14" x 60"	35.5 x 152.4	2
FF1472BK	14" x 72"	35.5 x 182.9	2
FF1824BK	18" x 24"	45.7 x 61.0	4
FF1830BK	18" x 30"	45.7 x 76.0	4
FF1836BK	18" x 36"	45.7 x 91.4	4
FF1842BK	18" x 42"	45.7 x 106.6	4
FF1848BK	18" x 48"	45.7 x 122.0	4
FF1854BK	18" x 54"	45.7 x 137.0	2
FF1860BK	18" x 60"	45.7 x 152.4	2
FF1872BK	18" x 72"	45.7 x 182.9	2
FF2424BK	24" x 24"	61.0 x 61.0	4
FF2430BK	24" x 30"	61.0 x 76.0	4
FF2436BK	24" x 36"	61.0 x 91.4	4
FF2442BK	24" x 42"	61.0 x 106.6	4
FF2448BK	24" x 48"	61.0 x 122.0	4
FF2454BK	24" x 54"	61.0 x 137.0	2
FF2460BK	24" x 60"	61.0 x 152.4	2
FF2472BK	24" x 72"	61.0 x 182.9	2

Black epoxy wine shelves also available see page 28 for details.

## Black Epoxy Coated Posts

Please specify either stationary [with leveling feet] or mobile post design when ordering.

Stationary Post Item #	Mobile Post Item #	Height		Case
		(in.)	(cm)	
FG007BK	FGN007BK	7	17.8	4
FG015BK		15	38.1	4
FG033BK	FGN033BK	33	83.8	4
FG054BK	FGN054BK	54	137.2	4
FG063BK	FGN063BK	63	160.0	4
FG074BK	FGN074BK	74	188.0	4
FG086BK	FGN086BK	86	218.4	4

Four sets of plastic split sleeves are included with each shelf.





**NSF APPROVED:** These commercial rated black epoxy coated shelves and accessories are recommended for dry storage applications only.



**1 YEAR LIMITED WARRANTY:** Focus Foodservice offers a one year limited warranty on our black epoxy shelves and posts against rust or corrosion under general usage.



**CROWN BRANDS**  
**STORAGE AND TRANSPORTATION**

### Shelf Ledges

Promote safety in your operation by using these heavy-duty ledges to keep items from protruding or falling from shelves. Ledges fit back or sides of shelving units. Ledges can be stacked on top of each other for additional height. Available for black epoxy shelves, green epoxy coated and chromate finishes (sizes and styles may vary).

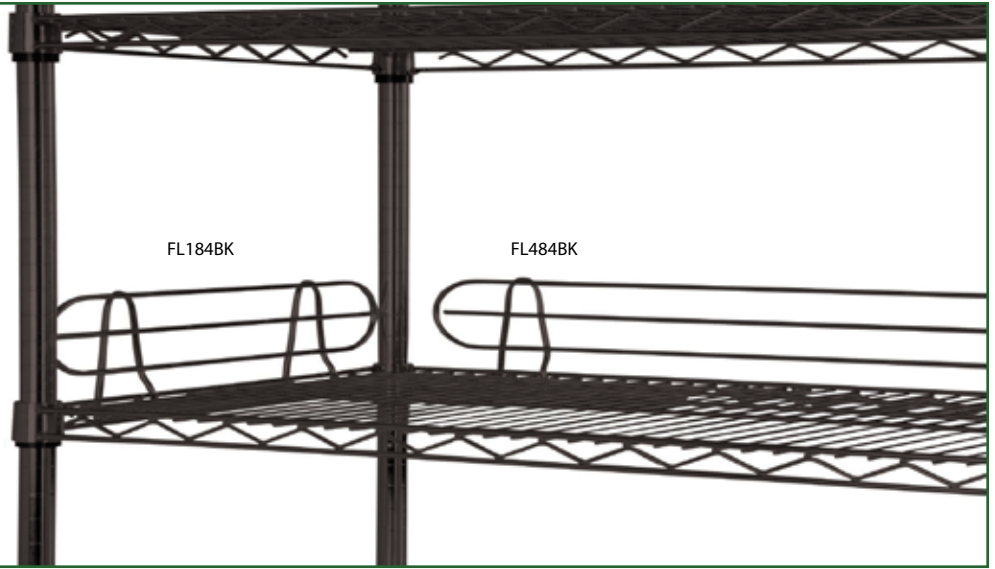

### Shelf Dividers

Keep your shelves well organized and orderly with these 8" (20.3 cm) high, pressure fit dividers. Order by shelf width. in black epoxy coated, green epoxy coated and chromate finishes (sizes may vary).



### Post Clamps

Secure shelving units together for maximum strength. It is recommended to use clamps at the front and back of the unit. These post clamps are available in black or green epoxy and chromate.



## Black Epoxy Accessories

Item #	Description	Case
FSD14BK	Shelf Divider 14" X 8" h (35.5 x 20.3 cm)	4
FSD18BK	Shelf Divider 18" X 8" h (45.7 x 20.3 cm)	4
FSD21BK	Shelf Divider 21" X 8" h (53.0 x 20.3 cm)	4
FSD24BK	Shelf Divider 24" X 8" h (61.0 x 20.3 cm)	4
FL184BK	Shelf Ledge 18" X 4" h (45.7 x 10.1 cm)	4
FL214BK	Shelf Ledge 21" X 4" h (53.0 x 10.1 cm)	4
FL244BK	Shelf Ledge 24" x 4" h (61.0 x 10.1 cm)	4
FL364BK	Shelf Ledge 30" x 4" h (76.2 x 10.1 cm)	4
FL484BK	Shelf Ledge 48" x 4" h (121.9 x 10.1 cm)	2
93333BK	S Hook, shelf connector - black epoxy (2 per pack)	50
FPOCLBK	Post clamps, black epoxy coated (2 per pack)	25

\* More shelving accessories available. Refer to pages 49-52 for more products.

### Shelf Connecting S Hooks

Use to eliminate 2 posts per adjacent unit. Two hooks required per shelf. Available in green epoxy coated, black epoxy coated or chromate finish. Packed 2 per package.



93333BK

# Chromate Shelves & Posts



**NSF APPROVED:** These commercial rated chromate finish shelves are ideal for dry storage application.



**1 YEAR LIMITED WARRANTY:** Focus Foodservice offers a one year limited warranty on our chromate finish shelves and posts against rust or corrosion under general condition usage.



## Chromate: The Ideal Solution for Dry Storage Needs.

These Zinc plated commercial rated steel wire with ultra-clear coated shelves are ideal for display and dry storage applications.

## Chromate Finish Shelves

Item #	Shelf Size (width x length)		Case
	(in.)	(cm)	
FF1236C	12" x 36"	30.5 x 91.4	4
FF1248C	12" x 48"	30.5 x 122.0	4
FF1260C	12" x 60"	30.5 x 152.4	2
FF1424C	14" x 24"	35.5 x 61.0	4
FF1430C	14" x 30"	35.5 x 76.0	4
FF1436C	14" x 36"	35.5 x 91.4	4
FF1442C	14" x 42"	35.5 x 106.6	4
FF1448C	14" x 48"	35.5 x 122.0	4
FF1460C	14" x 60"	35.5 x 152.4	2
FF1472C	14" x 72"	35.5 x 182.9	2
FF1818CH	18" x 18"	45.7 x 45.7	4
FF1824C	18" x 24"	45.7 x 61.0	4
FF1830C	18" x 30"	45.7 x 76.0	4
FF1836C	18" x 36"	45.7 x 91.4	4
FF1842C	18" x 42"	45.7 x 106.6	4
FF1848C	18" x 48"	45.7 x 122.0	4
FF1854C	18" x 54"	45.7 x 137.0	2
FF1860C	18" x 60"	45.7 x 152.4	2
FF1872C	18" x 72"	45.7 x 182.9	2
FF2124C	21" x 24"	53.0 x 61.0	4
FF2130C	21" x 30"	53.0 x 76.0	4
FF2136C	21" x 36"	53.0 x 91.4	4
FF2142C	21" x 42"	53.0 x 106.6	4
FF2148C	21" x 48"	53.0 x 122.0	4
FF2154C	21" x 54"	53.0 x 137.0	2
FF2160C	21" x 60"	53.0 x 152.4	2
FF2172C	21" x 72"	53.0 x 182.9	2
FF2424C	24" x 24"	61.0 x 61.0	4
FF2430C	24" x 30"	61.0 x 76.0	4
FF2436C	24" x 36"	61.0 x 91.4	4
FF2442C	24" x 42"	61.0 x 106.6	4
FF2448C	24" x 48"	61.0 x 122.0	4
FF2454C	24" x 54"	61.0 x 137.0	2
FF2460C	24" x 60"	61.0 x 152.4	2
FF2472C	24" x 72"	61.0 x 182.9	2
FF3036CH	30" x 36"	76.0 x 91.4	2
FF3060CH	30" x 60"	76.0 x 152.4	2
FF3648C	36" x 48"	91.4 x 122.0	2
FF3660CH	36" x 60"	91.4 x 152.4	2
FF3672CH	36" x 72"	91.4 x 182.9	2

The open wire design minimizes dust accumulation and allows a free circulation of air, greater visibility of stored items and optimum light penetration.

Zinc plated feet allow you to keep shelving unit level on uneven floors.

## Chromate Finish Posts

Please specify either stationary [with leveling feet] or mobile post design when ordering.

Stationary Post Item #	Mobile Post Item #	Height		Case
		(in.)	(cm)	
FG007C	FGN007C	7	17.8	4
FG013C	FGN013C	13	33.0	4
	FGN021CH	21	53.3	4
FG027CH	FGN027CH	27	68.6	4
FG033C	FGN033C	33	83.8	4
FG054C	FGN054C	54	137.2	4
FG063C	FGN063C	63	160.0	4
FG074C	FGN074C	74	188.0	4
FG086C	FGN086C	86	218.4	4

# Chromate Shelving Kits [Stationary and Mobile]



**CROWN BRANDS**  
STORAGE AND  
TRANSPORTATION

## All-in-One Shelving Kits Great Cash and Carry Opportunities

Provide a complete shelving unit in a single box.

Each kit contains:

4 shelves with split sleeves & 4 each 74" stationary split posts shipped in white corrugated box with a full color label.

Item #	Description	Case
FK183674CH	Kit includes 4 each 18" x 36" (45.7 x 91.4 cm) shelves & 4 each 74" (188.0 cm) split posts	1
FK184874CH	Kit includes 4 each 18" x 48" (45.7 x 122.0 cm) shelves & 4 each 74" (188.0 cm) split posts	1
FK243674CH	Kit includes 4 each 24" x 36" (61.0 x 91.4 cm) shelves & 4 each 74" (188.0 cm) split posts	1
FK244874CH	Kit includes 4 each 24" x 48" (61.0 x 122.0 cm) shelves & 4 each 74" (188.0 cm) split posts	1



Each Kit includes:  
4 or 5 Chromate shelves  
4 Chromate 63" (160.0 cm) posts  
4 each 5" (12.7cm) polyurethane casters  
(2 swivel/2 swivel w/brake)  
4 revolving bumpers



FMK1836694CH

## Stem Caster Carts Easy to Order, Simple to Build.

### 4 Shelf Models

Item #	Shelf Size (width x length)		Case
	(in.)	(cm)	
FMK1836694CH	18" x 36"	45.7 x 91.4	1
FMK1848694CH	18" x 48"	45.7 x 122.0	1
FMK1860694CH	18" x 60"	45.7 x 152.4	1
FMK2136694CH	21" x 36"	53.0 x 91.4	1
FMK2148694CH	21" x 48"	53.0 x 122.0	1
FMK2160694CH	21" x 60"	53.0 x 152.4	1
FMK2436694CH	24" x 36"	61.0 x 91.4	1
FMK2448694CH	24" x 48"	61.0 x 122.0	1
FMK2460694CH	24" x 60"	61.0 x 152.4	1

### 5 Shelf Models

Item #	Shelf Size (width x length)		Case
	(in.)	(cm)	
FMK1836695CH	18" x 36"	45.7 x 91.4	1
FMK1848695CH	18" x 48"	45.7 x 122.0	1
FMK1860695CH	18" x 60"	45.7 x 152.4	1
FMK2136695CH	21" x 36"	53.0 x 91.4	1
FMK2148695CH	21" x 48"	53.0 x 122.0	1
FMK2160695CH	21" x 60"	53.0 x 152.4	1
FMK2436695CH	24" x 36"	61.0 x 91.4	1
FMK2448695CH	24" x 48"	61.0 x 122.0	1
FMK2460695CH	24" x 60"	61.0 x 152.4	1

Final overall height with casters included: 69" (175.3 cm)

# Chromate Trucks and Tools

## Equipped to Handle the Everyday Obstacles

### Heavy-Duty Mobile Kits and Accessories

#### Chromate Wire Shelf Truck

These well-suited transportation carts consists of four shelves, 63" staked posts, aluminum split sleeves and an aluminum truck dolly.

Item #	Shelf Size (width/length)	Case
FST243663CH	24" x 36" (61.0 x 91.4 cm)	1
FST244863CH	24" x 48" (61.0 x 122.0 cm)	1
FST246063CH	24" x 60" (61.0 x 152.4 cm)	1

In demanding use situations and where thresholds are continually encountered, we recommend the use of staked posts and aluminum split sleeves.



FK244874CH

#### Replacement Mounting Hardware for Enclosure Panel

Item #	Description	Case
FEPHDWRE	Contains 4 S hooks plus bolts and nuts	50



#### Aluminum Truck Dollies

Features a heavy-duty extruded aluminum frame with full wrap around bumpers. Designed for use on a variety of Focus shelving solutions, including standard shelving systems, security cages, and enclosure units. Minimal parts for fast and easy assembly. Features swivel plate casters with non-marking 5" (12.7 cm) polyurethane wheels (2 with brakes).

FST244863CH



Item #	Fits Shelf Size (width/length)	Case
FTDA2436	24" x 36" (61.0 x 91.4 cm)	1
FTDA2448	24" x 48" (61.0 x 122.0 cm)	1
FTDA2460	24" x 60" (61.0 x 152.4 cm)	1

#### Replacement Casters for Aluminum Truck Dollies

Item #	Description	Case
FTDPC5C	Replacement swivel plate caster	16
FTDPC5B	Replacement swivel plate caster with brake	16



Requires a 2" retaining (snap) pliers to assemble (not included).

#### Aluminum Split Sleeves

For high temperature, demanding, or conductive applications. Zinc retainer rings. 4 sets per bag. 1 set required per shelf.

Item #	Description	Case
FFSALSLV	Tapered aluminum split sleeves (4 pair)	150

#### Staked Posts - Chromate Finish

Bottom foot insert is staked into the bottom of the post to guarantee a more durable connection in demanding applications. Post bolt connects through underside of the dolly and into the post foot receptacle.

Item #	Height	Case
FGSTK054CH	54" (137.2 cm)	4
FGSTK063CH	63" (160.0 cm)	4



# More Opportunities to Get You Organized.



**CROWN BRANDS**  
STORAGE AND  
TRANSPORTATION

## Shelf Ledges and Dividers

Promote safety in your operation by using these heavy-duty ledges to keep items from protruding or falling from shelves. Ledges fit back or sides of shelving units. Ledges can be stacked on top of each other for additional height. Available for black epoxy shelves, green epoxy coated and chromate finishes (sizes and styles may vary).

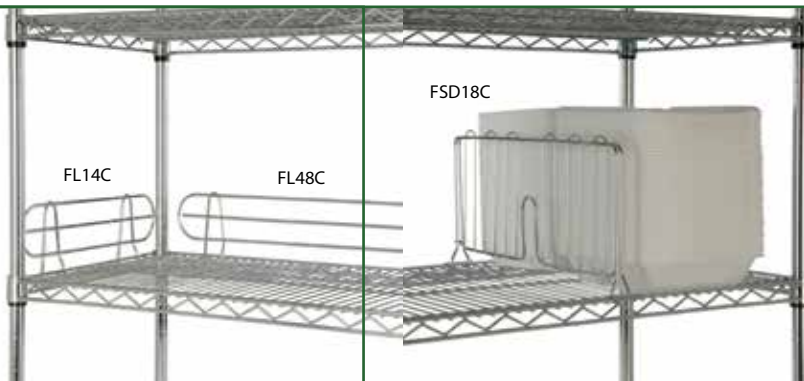

Keep your shelves well organized and orderly with these 8" (20.3 cm) high, pressure fit dividers. Order by shelf width. Dividers available in chromate or black epoxy coated (sizes may vary).

## Wire Can Rack

FFCR10CH



### FIFO's Best Friend.

Get more out of your shelving and proper inventory rotation with this front-loading, front dispensing can rack. Holds 8 each #10 cans or 12 each #5 cans. Fits on 24" (61.0 cm) wide shelves.

## Post Clamps

Secure shelving units together for maximum strength. It is recommended to use clamps at the front and back of the unit. These post clamps are available in chromate, black or green epoxy.

FPOCL



## Shelf Connecting

### S Hooks

Use to eliminate 2 posts per adjacent unit. Two hooks required per shelf. Available in chromate, green epoxy or black epoxy coated. Packed 2 per package



93333

## Chromate Accessories

Item #	Description	Case
FSD18C	Shelf Divider 18" X 8" h (45.7 x 20.3 cm)	4
FSD24C	Shelf Divider 24" X 8" h (61.0 x 20.3 cm)	4
FL184C	Shelf Ledge 18" X 4" h (45.7 x 10.1 cm)	4
FL214C	Shelf Ledge 21" X 4" h (53.0 x 10.1 cm)	24
FL244C	Shelf Ledge 24" x 4" h (61.0 x 10.1 cm)	4
FL364C	Shelf Ledge 30" x 4" h (76.2 x 10.1 cm)	4
FL484C	Shelf Ledge 48" x 4" h (121.9 x 10.1 cm)	2
FL604C	Shelf Ledge 60" x 4" h (152.4 x 10.1 cm)	2
FFCR10CH	Wire Can Rack 24 <sup>13/16</sup> " x 7 <sup>7/8</sup> " x 13 <sup>5/16</sup> " h (63.1x 20 x 33.8 cm)	1
FPOCL	Post clamps, chromate finish (2 per pack)	25
93333	S Hook, shelf connector - chromate (2 per pack)	50
FWPSBCH	Security bracket, chromate finish (2 per pack)	24

## Security Brackets

Brackets provide the opportunity to secure a unit to the wall for greater safety and security. Spacing is 2" (5.1 cm) off wall. Available in chromate or green epoxy finish.



FWPSBCH

\* More shelving accessories available. Refer to pages 49 - 53 for more products.

# Heavy-Duty Dunnage Shelving



**NSF APPROVED:** These commercial rated heavy-duty dunnage shelves are ideal for any more load-bearing storage application. Use the green epoxy for any storage need, including coolers. Chromate style is recommended for dry storage only.

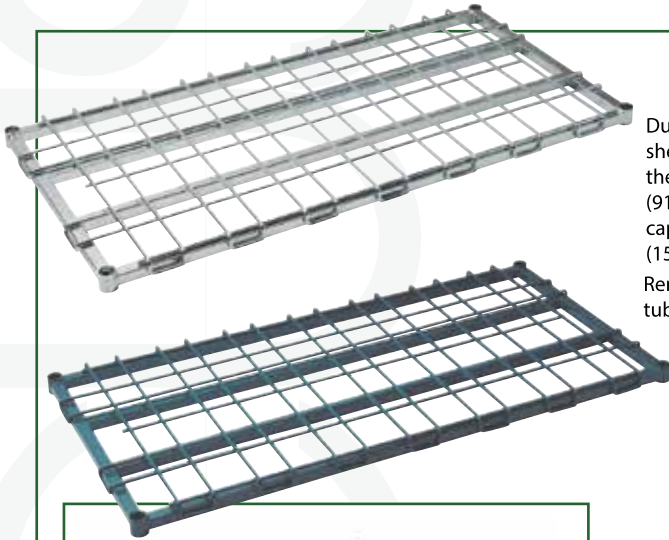

## Heavy-Duty Shelves with Wire Mats

Dunnage shelves offer considerably more weight-bearing capacity than other Focus shelves. They can be combined with other Focus shelves to provide extra strength at the lower levels of a shelving unit where the heaviest loads will be placed. The 36" (91.4 cm) length shelf has a 1,600-pound (727 kg) uniformly distributed static load capacity, the 48" (121.9 cm) shelf holds up to 1,300-pounds (591 kg), and the 60" (152.5 cm) shelf holds up to 1,000 pounds (455 kg).

Removable wire deck (5/16" / 8.0 mm) fits over reinforced 1" (2.5 cm) square, tubular frame and lifts off for easy, thorough cleaning.

Chromate Item #	Green Epoxy Coated Item #	Shelf Size (width x length)		Case
		(in.)	(cm)	
FFSM1836CH	FFSM1836GN	18" x 36"	45.7 x 91.4	1
FFSM1848CH	FFSM1848GN	18" x 48"	45.7 x 122.0	1
FFSM1860CH	FFSM1860GN	18" x 60"	45.7 x 152.4	1
FFSM2436CH	FFSM2436GN	24" x 36"	61.0 x 91.4	1
FFSM2448CH	FFSM2448GN	24" x 48"	61.0 x 122.0	1
FFSM2460CH	FFSM2460GN	24" x 60"	61.0 x 152.4	1



## Beer Keg Racks - Chromate Finish

These racks endure the heavy load of full kegs and the continual impact of being loaded and unloaded. 2 shelf design doubles storage capacity and creates a neat and orderly way to store kegs for easier identification of inventory and rotation of stock. The uniformly distributed static load capacity is 1,300-pounds (591 kg) for 48" (121.9 cm) shelves and 1,000 pounds (455 kg) for 60" (152.5 cm) shelves. Removable wire deck (5/16" / 8.0 mm) fits over reinforced 1" (25 mm) square tubular frame, lifts off for easy, thorough cleaning, and makes loading and unloading kegs much easier. 54" (137.0 cm) high units consist of 2 each heavy duty shelves with wire mats, 2 each three sided frames for added strength and stability, and 4 each 54" (137.0 cm) posts with leveling feet. 63" (160.0 cm) high units consist of 2 each heavy duty shelves with wire mats, 2 each three sided frames for added strength and stability, 1 each wire shelf, and 4 each 63" (160.0 cm) posts with leveling feet.

Item #	Dimensions (width/length/height)		Keg Capacity	Case
	(in.)	(cm)		
FBKR184854	18" x 48" x 54"	45.7 x 122.0 x 137.2	4	1
FBKR186054	18" x 60" x 54"	45.7 x 152.4 x 137.2	6	1
FBKR184863	18" x 48" x 63"	45.7 x 122.0 x 160.0	4	1
FBKR186063	18" x 60" x 63"	45.7 x 152.4 x 160.0	6	1



## 3 Sided Tubular Frames

When storage demands require the lowest shelf to be placed 24" (61.0 cm) or more above the floor, use a 3 sided frame so the stability of your shelving unit is not compromised. Each support frame is manufactured from 1" (25.4 mm) square tubing.

Chromate Item #	Green Epoxy Coated Item #	Dimensions (width/length)		Case
		(in.)	(cm)	
FFSF1836CH	FFSF1836GN	18" x 36"	45.7 x 91.4	1
FFSF1848CH	FFSF1848GN	18" x 48"	45.7 x 122.0	1
FFSF1860CH	FFSF1860GN	18" x 60"	45.7 x 152.4	1
	FFSF2160GN	21" x 60"	53.0 x 152.4	1
FFSF2436CH	FFSF2436GN	24" x 36"	61.0 x 91.4	1
FFSF2448CH	FFSF2448GN	24" x 48"	61.0 x 122.0	1
FFSF2460CH	FFSF2460GN	24" x 60"	61.0 x 152.4	1

# Tubular Dunnage Racks [Stationary and Mobile]



**CROWN BRANDS**  
STORAGE AND  
TRANSPORTATION

## Heavy-Duty Dunnage Racking

The low profile of Focus dunnage racks makes it easy to store large, bulky items off the floor without taking up valuable shelf space. Removable wire mat (5/16" / 8.0 mm) lifts off for easy and thorough cleaning. Offset wire design raises mat above post caps, preventing items from snagging or tearing. Top and lower support frames are made of 1" (25.4 mm) square tubing. These dunnage racks provide fast, secure assembly without the use of any special tools. Available in chromate or green epoxy coated finish.

### Stationary Dunnage Racks with Wire Mats

Lower 3 sided support frame is open in front – no need to move the rack to clean beneath it. Open wire grid minimizes dust and moisture accumulation on mat. Leveling feet compensate for surface irregularities. Racks are 131/2" (342.9 mm) high including cap and leveling feet. Available in chromate or green epoxy coated finish.

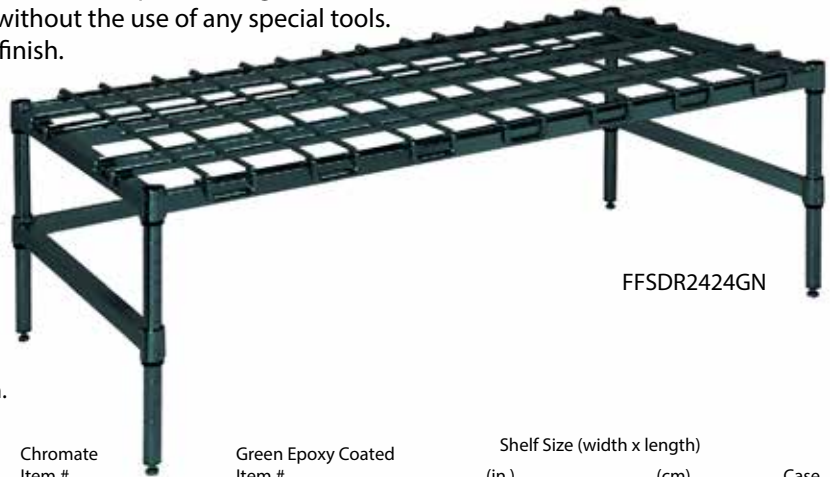

FFSDR2424GN



FFSDR1836CH

Chromate Item #	Green Epoxy Coated Item #	Shelf Size (width x length)		Case
		(in.)	(cm)	
FFSDR1836CH	FFSDR1836GN	18" x 36"	45.7 x 91.4	1
FFSDR1848CH	FFSDR1848GN	18" x 48"	45.7 x 122.0	1
FFSDR1860CH	FFSDR1860GN	18" x 60"	45.7 x 152.4	1
FFSDR2436CH	FFSDR2436GN	24" x 36"	61.0 x 91.4	1
FFSDR2448CH	FFSDR2448GN	24" x 48"	61.0 x 122.0	1
FFSDR2460CH	FFSDR2460GN	24" x 60"	61.0 x 152.4	1

### Mobile Dunnage Racks with Wire Mats

Two swivel casters and two swivel/brake casters provide excellent maneuverability plus manageability. 5" (12.7 cm) casters have a non-marking polyurethane tread, designed for heavy-duty use. Includes 2 each swivel casters with brakes, 2 each swivel casters, and 4 each 5" (12.7 cm) revolving donut bumpers. Racks are 121/2" (31.8 cm) high including cap and casters. Available in chromate or green epoxy coated finish.

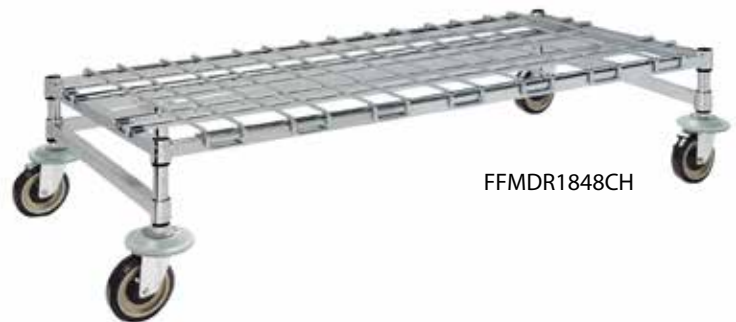

FFMDR1848CH



FFMDR1836GN

Chromate Item #	Green Epoxy Coated Item #	Shelf Size (width x length)		Case
		(in.)	(cm)	
FFMDR1836CH	FFMDR1836GN	18" x 36"	45.7 x 91.4	1
FFMDR1848CH	FFMDR1848GN	18" x 48"	45.7 x 122.0	1
FFMDR1860CH	FFMDR1860GN	18" x 60"	45.7 x 152.4	1
FFMDR2436CH	FFMDR2436GN	24" x 36"	61.0 x 91.4	1
FFMDR2448CH	FFMDR2448GN	24" x 48"	61.0 x 122.0	1
FFMDR2460CH	FFMDR2460GN	24" x 60"	61.0 x 152.4	1

# Aluminum Dunnage Racks



**NSF APPROVED:** These commercial rated aluminum dunnage racks are freezers, coolers, displays, as well as packaging and storage areas.



**LIFETIME / LIMITED WARRANTY:** We offer a lifetime warranty against rust or corrosion on our aluminum racks. Plus, our 5-year warranty covers any material defects and workmanship.

## Heavy-Duty Aluminum Dunnage Racks

Approved for use in freezers, coolers, displays, as well as packaging and storage areas. These heavy-duty all-welded aluminum racks keep product organized and off of the floor. tremendous selection of standard sizes are available that fit a wide variety of applications and allow you to maximize your space.

Constructed from high tensile, extruded type 6063-T5 aluminum tube, 1.5" x 1.75" (3.8 x 4.4 cm). 0.07" (0.18 cm) wall thickness, uniform throughout. (11.4 cm) centers.

Item #	Size (length/width/height)		Capacity		# of Support	
	(in.)	(cm)	(lbs)	(kg)	Bars	Case
FHADR36188	36" x 18" x 8"	91.4 x 45.7 x 20.3	3000	1364	4	6
FHADR361812	36" x 18" x 12"	91.4 x 45.7 x 30.5	3000	1364	4	6
FHADR362012	36" x 20" x 12"	91.4 x 50.8 x 30.5	3000	1364	4	6
FHADR36248	36" x 24" x 8"	91.4 x 61.0 x 20.3	2500	1136	5	6
FHADR362412	36" x 24" x 12"	91.4 x 61.0 x 30.5	2500	1136	5	6
FHADR48188	48" x 18" x 8"	122.0 x 45.7 x 20.3	2500	1136	4	6
FHADR481812	48" x 18" x 12"	122.0 x 45.7 x 30.5	2500	1136	4	6
FHADR48208	48" x 20" x 8"	122.0 x 50.8 x 20.3	2500	1136	4	6
FHADR482012	48" x 20" x 12"	122.0 x 50.8 x 30.5	2500	1136	4	6
FHADR48248	48" x 24" x 8"	122.0 x 61.0 x 20.3	2500	1136	5	6
FHADR482412	48" x 24" x 12"	122.0 x 61.0 x 30.5	2500	1136	5	6
FHADR60188	60" x 18" x 8"	152.4 x 45.7 x 20.3	2000	909	4	6
FHADR601812	60" x 18" x 12"	152.4 x 45.7 x 30.5	2000	909	4	6
FHADR602012	60" x 20" x 12"	152.4 x 50.8 x 30.5	2000	909	4	6
FHADR60248	60" x 24" x 8"	152.4 x 61.0 x 20.3	2000	909	5	6
FHADR602412	60" x 24" x 12"	152.4 x 61.0 x 30.5	2000	909	5	6



## Standard Duty Aluminum Dunnage Racks

For use in all the same applications as our heavy duty racks, but with less weight bearing capacity. Constructed from high tensile, extruded type 6063-T5 aluminum tube, 1.5" x 1.5" (3.8 x 3.8 cm). 0.062" (0.16 cm) wall thickness, uniform throughout. All heli-arc weld construction for better strength and sanitation. All seams welded. All feet capped with durable plastic inserts to prevent floor damage. Tube spacing on 4.5" (11.4 cm) centers. Lifetime guarantee against rust.

Item #	Size (length/width/height)		Capacity		# of Support	
	(in.)	(cm)	(lbs)	(kg)	Bars	Case
FADR302412	30" x 24" x 12"	76.0 x 61.0 x 30.5	2000	909	5	6
FADR36208	36" x 20" x 8"	91.4 x 50.8 x 20.3	2000	909	4	6
FADR362012	36" x 20" x 12"	91.4 x 50.8 x 30.5	2000	909	4	6
FADR362412	36" x 24" x 12"	91.4 x 61.0 x 30.5	2000	909	5	6
FADR422412	42" x 24" x 12"	106.6 x 61.0 x 30.5	2000	909	5	6
FADR48208	48" x 20" x 8"	122.0 x 50.8 x 20.3	2000	909	4	6
FADR482012	48" x 20" x 12"	122.0 x 50.8 x 30.5	2000	909	4	6
FADR482412	48" x 24" x 12"	122.0 x 61.0 x 30.5	2000	909	5	6
FADR60208	60" x 20" x 8"	152.4 x 50.8 x 20.3	1500	682	4	6
FADR602012	60" x 20" x 12"	152.4 x 50.8 x 30.5	1500	682	4	6
FADR602412	60" x 24" x 12"	152.4 x 61.0 x 30.5	1500	682	5	6

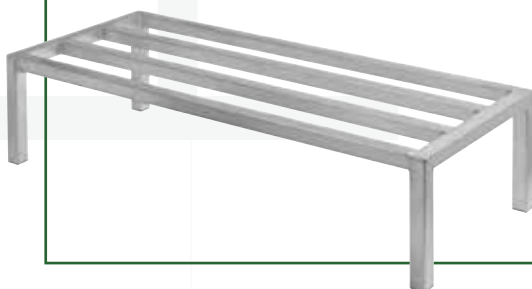



# Mobile Dunnage Racks Shelf Cart Kits



**CROWN BRANDS**  
STORAGE AND  
TRANSPORTATION

## Heavy Duty Aluminum Mobile Dunnage Racks

These versatile mobile racks eliminate wasted storage space. Optional handle makes pushing loads easier.

Constructed from high tensile, extruded type 6063-T5 aluminum tube, 1.5" x 1.75" (3.8 x 4.4 cm). 0.07" (0.18 cm) wall thickness, uniform throughout. All heli-arc weld construction for better strength and sanitation. All seams welded. 1200 lbs. (545.5 kgs) maximum distributed load capacity. Platform type casters with 1 1/4" x 5" (3.2 x 12.7 cm) diameter wheel, polyurethane tread and ball bearing axle. Two swivel with brakes and two rigid. Overall height 8.25" (21.0 cm).



*Optional handles make transportation easier.*

Item #	Size (width/length)		Capacity		# of Support Bars	Case
	(in.)	(cm)	(lbs)	(kg)		
FMADR2420	24" x 20"	61.0 x 50.8	1200	545	4	2
FMADR3620	36" x 20"	91.4 x 50.8	1200	545	4	2
FALHDL20	34" h (86.4 cm) Optional handle for 20" (50.8 cm) units					1
FMADR3624	36" x 24"	91.4 x 61.0	1200	545	5	2
FMADR4824	48" x 24"	122.0 x 61.0	1200	545	5	2
FALHDL24	34" h (86.4 cm) Optional handle for 24" (61.0 cm) units					1

## Wire Shelf Cart Kits



\* Shipped in Full Color Trilingual Merchandising Cartons



## Chromate Wire Shelf Kits

These extremely durable and versatile carts can be used in almost any part of your operation. U-shaped handles are single grooved every 1" (2.5 cm) and are double grooved every 8" (20.3 cm) for easier identification. Shelves can be adjusted in 1" (2.5 cm) increments. Two plastic post caps included providing you with the option of assembling the cart with 1 or 2 U-shaped handles. Includes 4" (10.8 cm) non-marking, industrial casters with rubber bumpers. Shipped knocked down.

Item #	Description	Size (width/length/height)	Case
FFC18362CH	2 shelf wire cart	18" x 36" x 37" (45.7 x 91.4 x 93.9 cm)	1
FFC18363C*	3 shelf wire cart	18" x 36" x 37" (45.7 x 91.4 x 93.9 cm)	1
FFC24362CH	2 shelf wire cart	24" x 36" x 37" (61.0 x 91.4 x 93.9 cm)	1
FFC24363CH*	3 shelf wire cart	24" x 36" x 37" (61.0 x 91.4 x 93.9 cm)	1

## Chrome Finish Kitchen Cart

This easy rolling cart is perfect for moving light products around any space. Comes complete with 3 each 14" x 24" (34.3 x 61.0 cm) shelves, 14 sets of plastic sleeves, 4 each 33" (83.8 cm) posts, 1 each extended push handle, and 4 each 3" (7.6 cm) diameter swivel casters (2 locking). Each kit comes in a full color display carton.

Item #	Description	Case
34458	Kitchen cart 13 1/2" x 23 1/2" x 35" high (34.3 x 59.7 x 88.9 cm)	1

\* Shipped in Full Color Trilingual Merchandising Cartons



**FOODSERVICE**

SOLUTIONS 24-37



## SOLUTION PROVIDED.

We don't just produce products, we provide solutions. Helping our customers save space, work more efficiently, protect their investment.

We aren't successful until you are.

Our storage solutions are inspired by our industry, from the dealers to the doers. We strive to lead by example, develop to the highest specifications create what our customers need... a product that serves its intended purpose, to provide a solution.

Day in, day out... year after year.

### FOCUS FOODSERVICE

Call: 800.968.3918

Fax: 800.968.4129

Click: [orders@crowns-brands.com](mailto:orders@crowns-brands.com)

Search: [www.crown-brands.com](http://www.crown-brands.com)

# Introducing: Our New 3 Shelf Folding Bus Cart

(more on page 37)



A gentle squeeze of the handles and this cart folds shut to an 8" width for easy storage behind doors, etc. The integrated latch holds the cart securely closed when not in use.

## Loaded with Features and Benefits, Before You Put One Thing On It!



# Safe & Security: Cages and Modules



CROWN BRANDS  
STORAGE AND  
TRANSPORTATION

**For Protection 24/7**

## Improved EZ-Latch and Hook System for Quicker Set-Up and More Secure Closure.

- Available as cage only, stationary model or mobile unit.
- Heavy duty chromate finish panels have open wire construction so checking contents of cage is easy.
- Locking bar on front door hooks both the top and bottom shelf for greater security.
- Each front door opens 270° for faster and easier loading and unloading of products.
- 6 convenient sizes to choose from to handle a variety of storage needs.
- Security cages can be attached to stationary or mobile shelving units greater flexibility.
- Add additional middle shelves for greater storage capacity.
- Shipped knocked down to save on freight costs. Unit assembles easily.

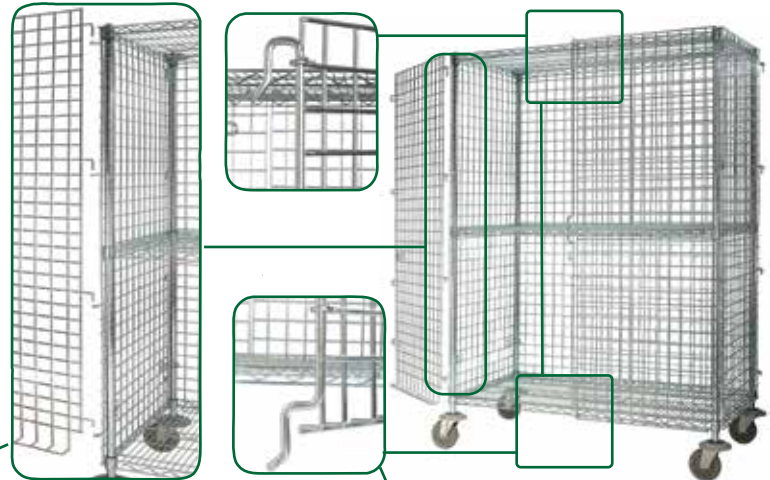

### Revised Panel Hangers

Make it easier to position and drop panels into place saving valuable time during installation.

### Modified Shepherd's Hook

Guides the doors into position for a more secure closure - no more misalignment.

## Heavy-Duty Mobile Security Cages - Chromate Finish\*

These feature everything included in our mobile security cages with 63" staked posts, aluminum split sleeves, and an aluminum truck dolly with 5" polyurethane wheels.

Size	2 Shelf Heavy-Duty Mobile Cage Item #	3 Shelf Heavy-Duty Mobile Cage Item #	4 Shelf Heavy-Duty Mobile Cage Item #	Case
24" x 36" x 63" h (61.0 x 91.4 x 160.0 cm)	FHDMSEC2436	FHDMSEC24363	FHDMSEC24364	1
24" x 48" x 63" h (61.0 x 122.0 x 160.0 cm)	FHDMSEC2448	FHDMSEC24483	FHDMSEC24484	1
24" x 60" x 63" h (61.0 x 152.4 x 160.0 cm)	FHDMSEC2460	FHDMSEC24603	FHDMSEC24604	1

\* Heavy-duty mobile security cages consist of chromate shelves, 4 each FGSTK063CH 63" chromate staked posts, aluminum truck dolly & aluminum split sleeves



## Security Module - Chromate Finish

- Converts standard 24" x 48" (61.0 x 122.0 cm) shelving units into security modules.
- Can enclose one or more areas of a unit.
- Fit between shelving spaced 20" (51.0 cm) apart on any Focus shelving unit. Modules include side panels, back panels, door and all mounting hardware. Shelves, posts, and locks not included.

Item #	Description	Case
FSECM2448CH	Security module - 24" x 48" x 20" h (61.0 x 122.0 x 50.8 cm)	1

Note: When multiple security units are used on one shelving unit, separate top and bottom shelves are necessary for each module.

Shipped in Full Color Trilingual Merchandising Cartons



# Chromate Security Cages [Conversion or Complete Kits]

**Security Cages** to convert your existing shelving unit or build from the ground up.

24/7 Protection on your investments from loss and minimize inventory shrinkage. Keep your product on the shelves where it's meant to be.

## Security Cages Only [Conversion Kits]\*

Convert your existing shelving unit into a security cage using this kit. These kits only contain the security cage, shelves or posts are not included.



Size (width/length/height)	Cage Only Item #	Case
18" x 36" x 63" (45.7 x 91.4 x 160.0 cm)	FSEC183663	1
18" x 48" x 63" (45.7 x 122.0 x 160.0 cm)	FSEC184863	1
18" x 60" x 63" (45.7 x 152.4 x 160.0 cm)	FSEC186063	1
24" x 36" x 63" (61.0 x 91.4 x 160.0 cm)	FSEC243663	1
24" x 48" x 63" (61.0 x 122.0 x 160.0 cm)	FSEC244863	1
24" x 60" x 63" (61.0 x 152.4 x 160.0 cm)	FSEC246063	1

\* Security cage only consists of front, back, and side panels, plus assembly hardware  
To create mobile cages, utilize 63" (160.0 cm) open bottom posts (Item No. FGN063C).  
For stationary applications, utilize 74" (188.0 cm) posts with leveling feet (Item No. FG074C).



FSSEC24484

## Stationary Security Cages - Chromate Finish\*\*

Size (width/length/height)	2 Shelf		3 Shelf		4 Shelf	
	Stationary Cage Item #	Stationary Cage Item #	Stationary Cage Item #	Stationary Cage Item #	Stationary Cage Item #	Case
18" x 36" x 63" (45.7 x 91.4 x 160.0 cm)	FSSEC1836	FSSEC18363	FSSEC18363	FSSEC18364	FSSEC18364	1
18" x 48" x 63" (45.7 x 122.0 x 160.0 cm)	FSSEC1848	FSSEC18483	FSSEC18483	FSSEC18484	FSSEC18484	1
18" x 60" x 63" (45.7 x 152.4 x 160.0 cm)	FSSEC1860	FSSEC18603	FSSEC18603	FSSEC18604	FSSEC18604	1
24" x 36" x 63" (61.0 x 91.4 x 160.0 cm)	FSSEC2436	FSSEC24363	FSSEC24363	FSSEC24364	FSSEC24364	1
24" x 48" x 63" (61.0 x 122.0 x 160.0 cm)	FSSEC2448	FSSEC24483	FSSEC24483	FSSEC24484	FSSEC24484	1
24" x 60" x 63" (61.0 x 152.4 x 160.0 cm)	FSSEC2460	FSSEC24603	FSSEC24603	FSSEC24604	FSSEC24604	1

\*\* Stationary security cages consist of chromate shelves & 4 each FG074C 74" chromate posts

## Mobile Security Cages - Chromate Finish\*\*\*

Size (width/length/height)	2 Shelf		3 Shelf		4 Shelf	
	Mobile Cage Item #	Mobile Cage Item #	Mobile Cage Item #	Mobile Cage Item #	Mobile Cage Item #	Case
18" x 36" x 63" (45.7 x 91.4 x 160.0 cm)	FMSEC1836	FMSEC18363	FMSEC18363	FMSEC18364	FMSEC18364	1
18" x 48" x 63" (45.7 x 122.0 x 160.0 cm)	FMSEC1848	FMSEC18483	FMSEC18483	FMSEC18484	FMSEC18484	1
18" x 60" x 63" (45.7 x 152.4 x 160.0 cm)	FMSEC1860	FMSEC18603	FMSEC18603	FMSEC18604	FMSEC18604	1
24" x 36" x 63" (61.0 x 91.4 x 160.0 cm)	FMSEC2436	FMSEC24363	FMSEC24363	FMSEC24364	FMSEC24364	1
24" x 48" x 63" (61.0 x 122.0 x 160.0 cm)	FMSEC2448	FMSEC24483	FMSEC24483	FMSEC24484	FMSEC24484	1
24" x 60" x 63" (61.0 x 152.4 x 160.0 cm)	FMSEC2460	FMSEC24603	FMSEC24603	FMSEC24604	FMSEC24604	1

\*\*\* Mobile security cages consist of chromate shelves, 4 each FGN063C 63" chromate posts, & 1 set of casters w/bumpers

IT IS RECOMMENDED THAT A MINIMUM OF 3 SHELVES BE USED WITH EACH CAGE (TOP, BOTTOM, AND MIDDLE)

# Green Epoxy Security Cages [Conversion or Complete Kits]



**CROWN BRANDS**  
STORAGE AND  
TRANSPORTATION

## Security Cages Conversion, Stationary or Mobile Kits

### Security Cages - Green Epoxy Coated

Same great features and construction as our chromate models, but in a green epoxy coated finish that is suited for wet environments. Ideal for situations where you want to secure select items and not an entire cooler or freezer. Each kit contains two front panels, two side panels, two back panels, back panel assembly hardware, and top loop assembly hardware.

To create mobile cages, utilize 63" (160.0 cm) open bottom posts (Item No. FGN063G). For stationary applications, utilize 74" (188.0 cm) posts with leveling feet (Item No. FG074G).

IT IS RECOMMENDED THAT A MINIMUM OF 3 SHELVES BE USED WITH EACH CAGE (TOP, BOTTOM, AND MIDDLE)

### Security Cages Only [Conversion Kits]\*

Convert your existing shelving unit into a security cage using this kit. These kits only contain the security cage, shelves or posts are not included.

Size	Cage Only Item #	Case
24" x 36" x 63" h (61.0 x 91.4 x 160.0 cm)	FSEC243663GN	1
24" x 48" x 63" h (61.0 x 122.0 x 160.0 cm)	FSEC244863GN	1
24" x 60" x 63" h (61.0 x 152.4 x 160.0 cm)	FSEC246063GN	1

### Stationary Security Cages - Green Epoxy Coated\*\*

Size	2 Shelf Stationary Cage Item #	3 Shelf Stationary Cage Item #	4 Shelf Stationary Cage Item #	Case
24" x 36" x 63" h (61.0 x 91.4 x 160.0 cm)	FSSEC2436GN	FSSEC24363GN	FSSEC24364GN	1
24" x 48" x 63" h (61.0 x 122.0 x 160.0 cm)	FSSEC2448GN	FSSEC24483GN	FSSEC24484GN	1
24" x 60" x 63" h (61.0 x 152.4 x 160.0 cm)	FSSEC2460GN	FSSEC24603GN	FSSEC24604GN	1

### Mobile Security Cages - Green Epoxy Coated\*\*\*

Size	2 Shelf Mobile Cage Item #	3 Shelf Mobile Cage Item #	4 Shelf Mobile Cage Item #	Case
24" x 36" x 63" h (61.0 x 91.4 x 160.0 cm)	FMSEC2436GN	FMSEC24363GN	FMSEC24364GN	1
24" x 48" x 63" h (61.0 x 122.0 x 160.0 cm)	FMSEC2448GN	FMSEC24483GN	FMSEC24484GN	1
24" x 60" x 63" h (61.0 x 152.4 x 160.0 cm)	FMSEC2460GN	FMSEC24603GN	FMSEC24604GN	1



Zinc plated feet allow you to keep shelving unit level on uneven floors. Triangular security feet (FTSFZ) are also available for additional stability or to bolt the to the floor (see accessories section).

\* Security cage only consists of front, back, and side panels, plus assembly hardware

\*\* Stationary security cages consist of green epoxy coated shelves & 4 each FG074G 74" green epoxy coated posts

\*\*\* Mobile security cages consist of green epoxy coated shelves, 4 each FGN063G 63" green epoxy coated posts & 1 set of casters (2 swivel & 2 swivel w/brakes) with bumpers

# Wire Wine Shelves & Kits



**NSF APPROVED:** These commercial rated black epoxy coated wire wine shelves do include zinc underplating, so they can be used in a cooler.



**FWSK3654CH**  
3 3/8" cradle width and 1" cradle depth

## Wine Shelves Single and Double [Black epoxy and Chromate]

Each bottle is supported individually by formed wires in each shelf so bottles will not bump against each other. Open wire construction keeps bottles and labels highly visible for easy reading and selection. Now available in black epoxy or chromate finish. Black epoxy shelves have zinc underplating so they can be used in a cooler.

Double bottle wine shelves provide twice the capacity in 15% less space. Double wine shelves can also be used with 24" x 36" (61.0 x 91.4 cm) and 24" x 48" (61.0 x 122.0 cm) security cages shown on pages 26 & 29 for greater protection of valuable assets. Approximately 80% of standard 750 ml bottles tested fit two deep in double wine shelves.



**FDWS2436CH**

Item #	Finish	Shelf Size (width x length)		Bottle Capacity	Case
		(in.)	(cm)	per Shelf	
<b>SINGLE SHELVES</b>					
FFWS1436BK	Black epoxy	14" x 36"	35.5 x 91.4	9	4
FFWS1448BK	Black epoxy	14" x 48"	35.5 x 122.0	12	4
FFWS1436CH	Chromate	14" x 36"	35.5 x 91.4	9	4
FFWS1448CH	Chromate	14" x 48"	35.5 x 122.0	12	4
<b>DOUBLE SHELVES</b>					
FDWS2436BK	Black epoxy	24" x 36"	61.0 x 91.4	18	4
FDWS2448BK	Black epoxy	24" x 48"	61.0 x 122.0	24	4
FDWS2436CH	Chromate	24" x 36"	61.0 x 91.4	18	4
FDWS2448CH	Chromate	24" x 48"	61.0 x 122.0	24	4

## Wine Shelf Kits Double [Chromate Only]



**FDWSK4854CH**

## Wine Shelf Kits Single [Black Epoxy and Chromate]

We now offer convenient kits for single and double shelves so you can order one item number to include posts and shelves. Kits with posts 63" (160.0 cm) and taller include 4 each security brackets that mount to the wall for greater stability.

Description	Black Epoxy Item #	Chromate Item #	Bottle Capacity	Case
<b>SINGLE SHELF KITS</b>				
Includes 8 each 14" x 36" (35.5 x 91.4 cm) shelves and 4 each 54" (137.2 cm) stationary posts	FWSK3654BK	FWSK3654CH	72	1
Includes 10 each 14" x 36" (35.5 x 91.4 cm) shelves and 4 each 63" (160.0 cm) stationary posts	FWSK3663BK	FWSK3663CH	90	1
Includes 12 each 14" x 36" (35.5 x 91.4 cm) shelves and 4 each 74" (188.0 cm) stationary posts	FWSK3674BK	FWSK3674CH	108	1
Includes 8 each 14" x 48" (35.5 x 91.4 cm) shelves and 4 each 54" (137.2 cm) stationary posts	FWSK4854BK	FWSK4854CH	96	1
Includes 10 each 14" x 48" (35.5 x 91.4 cm) shelves and 4 each 63" (160.0 cm) stationary posts	FWSK4863BK	FWSK4863CH	120	1
Includes 12 each 14" x 48" (35.5 x 91.4 cm) shelves and 4 each 74" (188.0 cm) stationary posts	FWSK4874BK	FWSK4874CH	144	1

Description	Item #	Capacity	Case
<b>DOUBLE SHELF KITS (Chromate Only)</b>			
Includes 8 each 24" x 36" (61.0 x 91.4 cm) shelves and 4 each 54" (137.2 cm) stationary posts	FDWSK3654CH	144	1
Includes 10 each 24" x 36" (61.0 x 91.4 cm) shelves and 4 each 63" (160.0 cm) stationary posts	FDWSK3663CH	180	1
Includes 12 each 24" x 36" (61.0 x 91.4 cm) shelves and 4 each 74" (188.0 cm) stationary posts	FDWSK3674CH	216	1
Includes 8 each 24" x 48" (61.0 x 91.4 cm) shelves and 4 each 54" (137.2 cm) stationary posts	FDWSK4854CH	192	1
Includes 10 each 24" x 48" (61.0 x 91.4 cm) shelves and 4 each 63" (160.0 cm) stationary posts	FDWSK4863CH	240	1
Includes 12 each 24" x 48" (61.0 x 91.4 cm) shelves and 4 each 74" (188.0 cm) stationary posts	FDWSK4874CH	288	1

# Wine Display Racks, Kits, Modules and Security Cages

## Wine Display Modules and Kits

### Display Wine Racks

A fast, easy, and economical way to store and display wine. Assembles in minutes without tools. Holds 82 bottles. Includes 2 each wine rack modules, 3 each 14" x 30" (35.5 x 76.0 cm) shelves, and 4 each 63" (160.0 cm) stationary posts.

Item #	Description	Pack
FDWR82BK	Display wine rack, black epoxy finish, holds 82 bottles	1
FDWR82CH	Display wine rack, chromate finish, holds 82 bottles	1

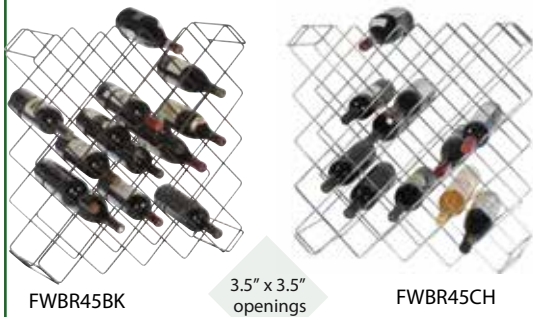

FWBR45BK

3.5" x 3.5" openings

FWBR45CH



FDWR82BK



When assembling security wine modules using double wine shelves, first wine shelf must be placed at least 8" above bottom shelf to allow attachment of side panels. Bottom wire shelf can be used for cartons bulk storage.



FMWR1836CH

### Wine Rack Modules

A convenient and easy way to store and display wine. Each unit holds up to 45 bottles. Labels are easy to see and identify. Can be free standing or secured to shelving. 26 1/2" x 26 1/2" x 8" deep (67.3 x 67.3 x 20.3 cm). Available in chromate or black epoxy finish.

Item #	Description	Case
FWBR45BK	Wine rack module, 45 bottle capacity, black epoxy	1
FWBR45CH	Wine rack module, 45 bottle capacity, chromate finish	1

Item #	Description	Case
FSWR1836CH*	Stationary security wine rack with 2 wine modules, holds 90 bottles, chromate finish, 18" x 36" (45.7 x 91.4 cm) cage	1
FMWR1836CH**	Mobile security wine rack with 2 wine modules, holds 82 bottles, chromate finish, 18" x 36" (45.7 x 91.4 cm) cage	1
FDSWR2436CH†	Stationary security wine rack with 8 each 24" x 36" (61.0 x 91.4 cm) double wine shelves, holds 144 bottles, chromate finish, 24" x 36" (61.0 x 91.4 cm) cage	1
FDSWR2448CH†	Stationary security wine rack with 8 each 24" x 48" (61.0 x 122.0 cm) double wine shelves, holds 192 bottles, chromate finish, 24" x 48" (61.0 x 122.0 cm) cage	1
FDMWR2436CH◇	Mobile security wine rack with 8 each 24" x 36" (61.0 x 91.4 cm) double wine shelves, holds 144 bottles, chromate finish, 24" x 36" (61.0 x 91.4 cm) cage	1
FDMWR2448CH◇	Mobile security wine rack with 8 each 24" x 48" (61.0 x 122.0 cm) double wine shelves, holds 192 bottles, chromate finish, 24" x 48" (61.0 x 122.0 cm) cage	1

\* Includes 2 each FWBR45CH, 1 each FSSEC1836C, & 1 extra FF1836C shelf  
 \*\* Includes 2 each FWBR45CH, 1 each FMSEC1836C, & 1 extra FF1836C shelf  
 † Includes 8 each double wine shelves & 1 each stationary security cage kit  
 ◇ Includes 8 each double wine shelves & 1 each mobile security cage kit

# Enclosure Panels for Shelving



**1 YEAR LIMITED WARRANTY:** Focus Foodservice offers a one year limited warranty on our black epoxy shelves and posts against rust or corrosion under general condition usage.

## Enclosure Panels Dimensions and Ordering Guide

An efficient way to enclose space for stationary or mobile applications. Can be used with chromate, black epoxy, or green epoxy wire shelving. Mounting hardware included with each panel.

Item #	Size (width/height)	Fits Post Height	Grid Opening (width/height)	Pack
FEP1854CH	12 $\frac{5}{16}$ " x 50 $\frac{3}{4}$ " (31.2 x 128.9 cm)	54" (137.2 cm)	3" x 3 $\frac{5}{8}$ " (7.7 x 9.2 cm)	4
FEP1863CH	12 $\frac{5}{16}$ " x 59 $\frac{5}{8}$ " (31.2 x 151.4 cm)	63" (160.0 cm)	3" x 3 $\frac{3}{4}$ " (7.7 x 9.4 cm)	4
FEP1874CH	12 $\frac{5}{16}$ " x 70 $\frac{3}{4}$ " (31.2 x 179.7 cm)	74" (188.0 cm)	3" x 3 $\frac{3}{4}$ " (7.7 x 9.4 cm)	4
FEP2454CH	18 $\frac{3}{8}$ " x 50 $\frac{3}{4}$ " (46.6 x 128.9 cm)	54" (137.2 cm)	3 $\frac{5}{8}$ " x 3 $\frac{5}{8}$ " (9.2 x 9.2 cm)	4
FEP2463CH	18 $\frac{3}{8}$ " x 59 $\frac{5}{8}$ " (46.6 x 151.4 cm)	63" (160.0 cm)	3 $\frac{5}{8}$ " x 3 $\frac{3}{4}$ " (9.2 x 9.4 cm)	4
FEP2474CH	18 $\frac{3}{8}$ " x 70 $\frac{3}{4}$ " (46.6 x 179.7 cm)	74" (188.0 cm)	3 $\frac{5}{8}$ " x 3 $\frac{3}{4}$ " (9.2 x 9.4 cm)	4

### Mounting Hardware for Enclosure Panel

Item #	Description	Pack
FEPHDWRE	Contains 4 S hooks plus bolts and nuts	50



FEP2463CH

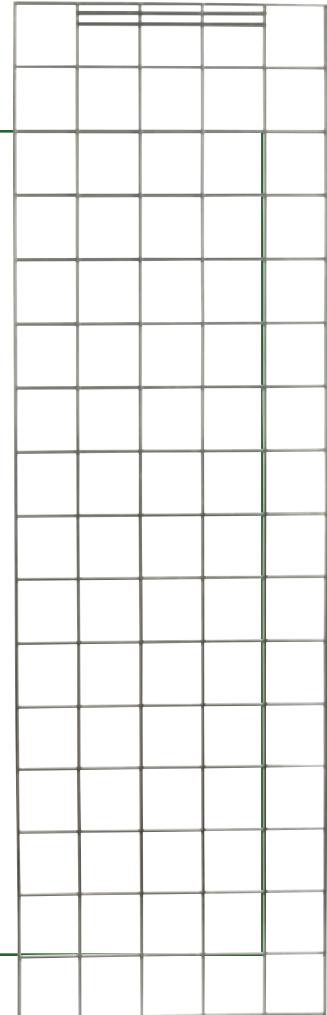

## Ordering Guide for Enclosure Panels

Ends - Panels required for EACH end according to shelf widths as follows:

Nominal Post Height	18" (45.7 cm) Nominal Shelf Width	21" (53.0 cm) Nominal Shelf Width	24" (61.0 cm) Nominal Shelf Width	30" (76.0 cm) Nominal Shelf Width	36" (91.4 cm) Nominal Shelf Width
54" (137.2 cm)	(1) FEP1854CH	(1) FEP1854CH	(1) FEP2454CH	(2) FEP1854CH	(1) FEP1854CH & (1) FEP2454CH
63" (160.0 cm)	(1) FEP1863CH	(1) FEP1863CH	(1) FEP2463CH	(2) FEP1863CH	(1) FEP1863CH & (1) FEP2463CH
74" (188.0 cm)	(1) FEP1874CH	(1) FEP1874CH	(1) FEP2474CH	(2) FEP1874CH	(1) FEP1874CH & (1) FEP2474CH

Backs - Requires multiple panels IN QUANTITIES SHOWN for specific shelf lengths:

Nominal Post Height	30" (76.0 cm) Nominal Shelf Length	36" (91.4 cm) Nominal Shelf Length	42" (106.6 cm) Nominal Shelf Length	48" (122.0 cm) Nominal Shelf Length	54" (137.0 cm) Nominal Shelf Length	60" (152.4 cm) Nominal Shelf Length	72" (182.9 cm) Nominal Shelf Length
54" (137.2 cm)	(2) FEP1854CH	(1) FEP1854CH & (1) FEP2454CH	(2) FEP2454CH	(2) FEP1854CH & (1) FEP2454CH	(1) FEP1854CH & (2) FEP2454CH	(3) FEP2454CH	(1) FEP1854CH & (3) FEP2454CH
63" (160.0 cm)	(2) FEP1863CH	(1) FEP1863CH & (1) FEP2463CH	(2) FEP2463CH	(2) FEP1863CH & (1) FEP2463CH	(1) FEP1863CH & (2) FEP2463CH	(3) FEP2463CH	(1) FEP1863CH & (3) FEP2463CH
74" (188.0 cm)	(2) FEP1874CH	(1) FEP1874CH & (1) FEP2474CH	(2) FEP2474CH	(2) FEP1874CH & (1) FEP2474CH	(1) FEP1874CH & (2) FEP2474CH	(3) FEP2474CH	(1) FEP1874CH & (3) FEP2474CH





# Enclosure Panel Carts and Accessories

## Enclosure Cart Kits

### Enclosure Panel Carts

Easy to order mobile carts. Include 4 each chromate finish shelves, 4 each 63" mobile posts, enclosure panels for 3 sides, casters (2 swivel, 2 swivel w/brake) and 4 bumpers

Item #	Shelf Size (width x height)	Pack
FEMK184869CH	18" x 48" (45.7 x 122.0 cm)	1
FEMK186069CH	18" x 60" (45.7 x 152.4 cm)	1
FEMK243669CH	24" x 36" (61.0 x 91.4 cm)	1
FEMK244869CH	24" x 48" (61.0 x 122.0 cm)	1
FEMK246069CH	24" x 60" (61.0 x 152.4 cm)	1

In demanding use situations and where thresholds are continually encountered, we recommend the use of staked posts and aluminum split sleeves (see below).



### Replacement Mounting Hardware for Enclosure Panel

Item #	Description	Case
FEPHDWRE	Contains (4) S hooks plus bolts and nuts	50



### Aluminum Truck Dollies

Features a heavy-duty extruded aluminum frame with full wrap around bumpers. Designed for use on a variety of Focus shelving solutions, including standard shelving systems, security cages, and enclosure units. Minimal parts for fast and easy assembly. Features swivel plate casters with non-marking 5" (12.7 cm) polyurethane wheels (2 with brakes).

Item #	Fits Shelf Size (width/length)	Case
FTDA2436	24" x 36" (61.0 x 91.4 cm)	1
FTDA2448	24" x 48" (61.0 x 122.0 cm)	1
FTDA2460	24" x 60" (61.0 x 152.4 cm)	1



### Casters for Aluminum Truck Dollies

Item #	Description	Case
FTDPC5C	Replacement swivel plate caster-set of 4	16
FTDPC5B	Replacement swivel plate caster w/brake set of 4	16



Requires retaining (snap) pliers to assemble (not included).

### Aluminum Split Sleeves

For high temperature, demanding, or conductive applications. Zinc retainer rings. 4 sets per bag. 1 set required per shelf.

Item #	Description	Case
FFSALSLV	Tapered aluminum split sleeves (4 pair)	150

### Staked Posts - Chromate Finish

Bottom foot insert is staked into the bottom of the post to guarantee a more durable connection in demanding applications. Post bolt connects through underside of the dolly and into the post foot receptacle.

Item #	Height	Pack
FGSTK054CH	54" (137.2 cm)	4
FGSTK063CH	63" (160.0 cm)	4



# HDS-PLUS™ High Density System



# Maximizes Usable Storage Capacity.



The Focus HDS-Plus system combines stationary and mobile shelving units with an overhead track system and a moving aisle into a highly efficient storage solution.

## **Easy To Order:**

Simple order process. All necessary parts are packaged into easy-to-order, ready-to-ship kits.  
**SHELVES & POSTS SOLD SEPARATELY.**

## **Quick and easy assembly:**

Shelving units and overhead track system can be put together in minutes.

## **5 Easy-to-Assemble Components:**

**Shelving/Posts:** Features high quality Focus shelves in a variety of finishes to suit your needs.

**Stationary Unit Kits:** Use on both ends of the storage system or as a middle unit to provide security and stability. Easily attaches to posts. Includes a variety of finishes, security feet, guide blocks and locking collars.

**Mobile Unit Kits:** Assembles quickly and easily to shelving posts on mobile units and allows for ease of movement. Includes caster channels, casters and guide blocks.

**Overhead Track Sets:** Available in lengths of 6 ft to 21 ft. \* Sections are connected together with easy-to-use track joiners allowing a large range of length combinations. End caps seal exposed ends of track tubes.

*\* Lengths 20' (610 cm) and over require an additional stationary unit in the center of the track.*

Increases storage capacity more than  
and more effectively utilizes space. **35%**

# HDS-PLUS™ High Density System

## Easy to Order. Simple to Install.



There are hundreds of different configurations of to make any foodservice operation infinitely more efficient. Select shelves and posts\* in stainless steel (solid or wire), green epoxy, fps-plus (solid or vented) or chromate finish.

\* post sizes are limited to 80" for stationary and 74" for mobile. (stainless steel posts are available in 74" for mobile units only)

### HDS-PLUS™ Components



High Density Storage System uses high quality Focus Foodservice shelving and posts.



Guide blocks are made from high density polyethylene designed specifically to fit in Focus posts.



Track sets consist of mirror-finish 304 stainless steel tubes - which fit precisely through guide blocks, track joiners - securely connect tubes, and end caps seal exposed tube ends.



Caster channels are made from 304 stainless steel. 6" Polyurethane stem casters feature heavy duty stainless axles. Weight capacity per caster is 400 lbs (182 kg).



Triangular security feet add additional stability to the stationary units.

### HDS-Plus™ High Density Shelving

Item #	Description	Case
FTSSU	Stationary unit kit	1
FTSMU18	18" (45.7 cm) Mobile unit kit	1
FTSMU21	21" (53.0 cm) Mobile unit kit	1
FTSMU24	24" (61.0 cm) Mobile unit kit	1
FTSTK6	Track set 6' (182.9 Cm)	1
FTSTK7	Track set 7' (213.4 Cm)	1
FTSTK8	Track set 8' (243.8 Cm)	1
FTSTK9	Track set 9' (274.3 Cm)	1
FTSTK10	Track set 10' (304.8 Cm)	1
FTSTK11	Track set 11' (335.3 Cm)	1
FTSTK12	Track set 12' (365.8 Cm)	1
FTSTK13	Track set 13' (396.2 Cm)	1
FTSTK14	Track set 14' (426.7 Cm)	1
FTSTK15	Track set 15' (457.2 Cm)	1
FTSTK16	Track set 16' (487.7 Cm)	1
FTSTK17	Track set 17' (518.2 Cm)	1
FTSTK18	Track set 18' (548.6 Cm)	1
FTSTK19	Track set 19' (579.1 Cm)	1
FTSTK20	Track set 20' (609.6 Cm)	1
FTSTK21	Track set 21' (640.1 Cm)	1

### Component Parts

Item #	Description	Case
FTSC6	6" (15.2 cm) Casters, set of 4	4
FTSFZ	Triangular security feet, zinc, (4 per pkg)	25
FTSGB	Guide blocks, set of 4	60
FTSJ2	Track joiners, set of 2	24
FTSLC	Locking collars, set of 4 w/Allen key	30
FTST2	2' (61.0 cm) Track tube set (2 pieces)	20
FTST3	3' (91.4 cm) Track tube set (2 pieces)	20
FTST5	5' (152.4 cm) Track tube set (2 pieces)	10
FTSCAP	End caps for track tubes, set of 4	4
FTSU18	18" (45.7 cm) Stainless steel caster channels, set of 2	10
FTSU21	21" (53.0 cm) Stainless steel caster channels, set of 2	10
FTSU24	24" (61.0 cm) Stainless steel caster channels, set of 2	1

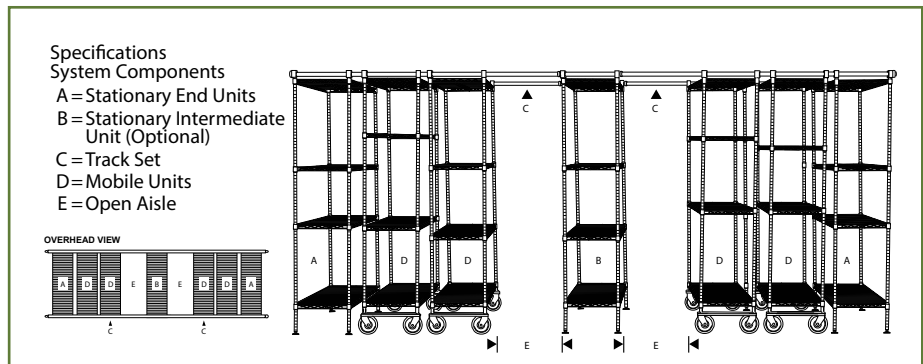

# HDS-PLUS™ High Density System Shelving and Post Selector



**CROWN BRANDS**  
STORAGE AND TRANSPORTATION

## HDS-PLUS SYSTEM Shelving Requirements

- Shelf Widths: 18", 21" and 24".
- Shelf Lengths: 24", 30", 36", 42", 48", 54", 60" and 72".
- Shelf Types: Stainless steel, FPS-Plus, Green Epoxy and Chromate.
- Warranty: 1 year on components and chromate shelves/posts.  
12 years on polymer shelves and green epoxy shelves/posts.  
12 years on stainless steel shelves/posts
- Need help with your specifications? Ask your Focus Foodservice sales rep about our HDS-PLUS™ Configurator.



## Shelves

Shelf Size (width/length) (in.)	(cm)	Chromate Item #	Green Epoxy Item #	FPS-Plus Vented Item #	FPS-Plus Solid Item #	Stainless Steel Solid Item #	Solid Steel Wire Item #	Case
18" x 24"	45.7 x 61.0	FF1824C	FF1824G	FPS1824VNGN	FPS1824SOGN	FF1824SSS		
18" x 30"	45.7 x 76.0	FF1830C	FF1830G	FPS1830VNGN	FPS1830SOGN	FF1830SSS		
18" x 36"	45.7 x 91.4	FF1836C	FF1836G	FPS1836VNGN	FPS1836SOGN	FF1836SSS	FF1836WRSS	4
18" x 42"	45.7 x 106.6	FF1842C	FF1842G	FPS1842VNGN	FPS1842SOGN	FF1842SSS		
18" x 48"	45.7 x 122.0	FF1848C	FF1848G	FPS1848VNGN	FPS1848SOGN	FF1848SSS	FF1848WRSS	4
18" x 54"	45.7 x 137.0	FF1854C	FF1854G	FPS1854VNGN	FPS1854SOGN			2
18" x 60"	45.7 x 152.4	FF1860C	FF1860G	FPS1860VNGN	FPS1860SOGN	FF1860SSS	FF1860WRSS	2
18" x 72"	45.7 x 182.9	FF1872C	FF1872G	FPS1872VNGN	FPS1872SOGN			
21" x 24"	53.0 x 61.0	FF2124C	FF2124G	FPS2124VNGN	FPS2124SOGN			4
21" x 30"	53.0 x 76.0	FF2130C	FF2130G	FPS2130VNGN	FPS2130SOGN			4
21" x 36"	53.0 x 91.4	FF2136C	FF2136G	FPS2136VNGN	FPS2136SOGN			4
21" x 42"	53.0 x 106.6	FF2142C	FF2142G	FPS2142VNGN	FPS2142SOGN			4
21" x 48"	53.0 x 122.0	FF2148C	FF2148G	FPS2148VNGN	FPS2148SOGN			4
21" x 54"	53.0 x 137.0	FF2154C	FF2154G	FPS2154VNGN	FPS2154SOGN			2
21" x 60"	53.0 x 152.4	FF2160C	FF2160G	FPS2160VNGN	FPS2160SOGN			2
21" x 72"	53.0 x 182.9	FF2172C	FF2172G	FPS2172VNGN	FPS2172SOGN			2
24" x 24"	61.0 x 61.0	FF2424C	FF2424G	FPS2424VNGN	FPS2424SOGN	FF2424SSS		
24" x 30"	61.0 x 76.0	FF2430C	FF2430G	FPS2430VNGN	FPS2430SOGN	FF2430SSS		
24" x 36"	61.0 x 91.4	FF2436C	FF2436G	FPS2436VNGN	FPS2436SOGN	FF2436SSS	FF2436WRSS	4
24" x 42"	61.0 x 106.6	FF2442C	FF2442G	FPS2442VNGN	FPS2442SOGN	FF2442SSS		
24" x 48"	61.0 x 122.0	FF2448C	FF2448G	FPS2448VNGN	FPS2448SOGN	FF2448SSS	FF2448WRSS	4
24" x 54"	61.0 x 137.0	FF2454C	FF2454G	FPS2454VNGN	FPS2454SOGN			2
24" x 60"	61.0 x 152.4	FF2460C	FF2460G	FPS2460VNGN	FPS2460SOGN	FF2460SSS	FF2460WRSS	2
24" x 72"	61.0 x 182.9	FF2472C	FF2472G	FPS2472VNGN	FPS2472SOGN			

## Posts

Description	Height (in.)	(cm)	Chromate Item #	Green Epoxy Item #	Stainless Steel	Case
80" Posts for Stationary Units	80"	203.2	FG080CH	FG080GN		4
74" Posts for Mobile Units	74"	188.0	FGN074C	FGN074G	FGN074SS	4

# Z RACK: Work Hard, Rest Eazy.



**NSF APPROVED:** These commercial rated aluminum bakery racks are constructed for ultra heavy-duty use.



**LIFETIME / LIMITED WARRANTY:** We offer a lifetime warranty against rust or corrosion on our aluminum racks. Plus, our 5-year warranty covers any material defects and workmanship.

## Welded, Nestable Aluminum Sheet Pan Racks

These ultra heavy-duty, end-loading welded racks are truly remarkable. With their unique "Z Frame" support construction, they nest while not in use, saving huge amounts of space. Made from type 6063-T5 ultra-strong aluminum. 1 1/4" (3.2 cm) ribbed slides for easier loading and unloading of pans. 5" (12.7cm) non-marking polyurethane casters- 2 swivel & 2 swivel with brakes. 20 13/16" x 26" x 70" h (52.9 x 66.0 x 177.8 cm).



Item #	Description	Slide Spacing	Case
FAZNBR12	Welded end-load aluminum Z Rack, 12 pan capacity	3" (7.6 cm)	6
FAZNBR20	Welded end-load aluminum Z Rack, 20 pan capacity	3" (7.6 cm)	1



Z Racks nest together when not in use for great compact storage.

FAKDBR20



FAZNBR20

## K/D Aluminum Sheet Pan Racks

Economical solution for storage and transport of sheet pans. Easiest to assemble rack on the market! Made from type 6063-T5 ultra-strong aluminum. 1 1/4" (3.2 cm) ribbed slides for easier loading and unloading of pans. 5" (12.7 cm) nonmarking polyurethane swivel casters. 12 or 20 pan capacity models. 2013/16" x 26" x 70" h (52.9 x 66.0 x 177.8 cm).

Item #	Description	Slide Spacing	Case
FAKDBR12*	K/D end-load aluminum rack, 12 pan capacity	5" (12.7 cm)	1
FAKDBR20*	K/D end-load aluminum rack, 20 pan capacity	3" (7.6 cm)	1

\*Shippable by UPS or Fedex



FBR CNF

### Specialized Solution

3 zippers for convenient and easy removal and placement of cover over rack. Can be used for end and front load sheet pan racks. Approved for use in dry storage, coolers and freezers without cracking. 12 mil thickness.

Item #	Description	Case
FBR CNF	Nylon cover for full size bakery racks - 24" x 28.5" x 62.5" (61.0 x 72.4 x 158.8 cm)	10

## Replacement Casters for Aluminum Bakery Racks

Replacement casters available in swivel or swivel with brake

Item #	Description	Case
FBR CST5B	5" (12.7 cm) swivel stem caster w/brake for aluminum bakery racks	4
FBR CST5S	5" (12.7 cm) swivel stem caster for aluminum bakery racks	4

These casters fit most standard bakery racks.





**CROWN BRANDS**  
STORAGE AND  
TRANSPORTATION

# Carts and Dolly

## [Form & Function]

**NEW**  
PRODUCT



### 3 Shelf Folding Cart

- Heavy duty stainless steel & polymer construction for added durability
- 28" x 19" x 36 w/4" heavy duty swivel casters, two with brakes
- Folds to a narrow 8" width for easy storage
- Top shelf features ergonomic handles
- Rounded design suitable for front or back of house use featuring marine edges to keep contents in place
- Integrated lock for secure closing
- Honeycomb pattern under-shelf ribbing creates a light weight cart with great load bearing capacity
- Textured surfaces to mask scratches and wear

### Stainless Steel Utility Carts

- Ultra-durable welded construction
  - Reinforced hemmed front edge on shelves for increased strength
  - Bumpers on legs/handle protect walls/doors
  - Sound deadening panels under shelves minimize vibrations and noise
  - 300 lb (135 kg) carts feature 22 gauge shelves and 20 gauge legs.
  - 500 lb (230 kg) carts feature 20 gauge shelves and 18 gauge legs.
- \*Shippable via UPS or FedEx.



Integrated lock for secure closing



Center support doubles as carrying handle



Honeycomb pattern reduces weight, increases strength



Item#	Weight Capacity	Shelf Size	Height Between Shelves	Caster Size	Caster Type	Overall Size	90312 Case
<b>NEW</b> FBC2819B	350 lbs (135 kg)	19" x 28" (39.4 x 61.0 cm)	11¾" (29.8 cm)	4" (10.2 cm)	All Swivel 2 Brake	19" x 28" x 36" (41.3 x 69.9 x 81.6 cm)	1
90312*	300 lbs (135 kg)	15½" x 24" (39.4 x 61.0 cm)	11¾" (29.8 cm)	3½" (8.9 cm)	All Swivel	16¼" x 27½" x 32½" (41.3 x 69.9 x 81.6 cm)	1
90322	300 lbs (135 kg)	18" x 27" (45.7 x 68.6 cm)	11¾" (29.8 cm)	3½" (8.9 cm)	All Swivel	18¾" x 30¾" x 33" (46.7 x 78.1 x 83.8 cm)	1
90411*	500 lbs (230 kg)	15½" x 24" (39.4 x 61.0 cm)	11⅞" (30.2 cm)	4" (10.2 cm)	All Swivel	16¾" x 27⅞" x 32½" (42.5 x 70.2 x 81.6 cm)	1
90422	500 lbs (230 kg)	18" x 27" (45.7 x 68.6 cm)	11⅞" (30.2 cm)	4" (10.2 cm)	All Swivel	19" x 31" x 32½" (48.3 x 78.7 x 81.6 cm)	1
90444	500 lbs (230 kg)	21" x 35" (53.3 x 88.9 cm)	13⅞" (33.3 cm)	5" (12.7 cm)	All Swivel Non Marking Polyurethane	22⅞" x 39¼" x 37¼" (56.8 x 99.7 x 94.6 cm)	1



### Aluminum Dish Rack Dolly with Handle

This convenient and easy to roll dolly with handle accommodates all standard glass and dish racks. 21½" (54.6 cm) square. 61/8" (15.4 cm) high without handle and 33¾" (84.3 cm) high with handle. Lightweight aluminum is easy to roll. Convenient draining holes so water does not pool. 5" (12.7 cm) non-marking polyurethane swivel casters. Non-marking corner bumpers. 30" (76.2 cm) aluminum handle included.

Item #	Description	Case
FDRDA21H	Aluminum dish rack dolly with handle	1

# FOCUS

**FOODSERVICE**

WALL STORAGE: 38-45

## MAXIMIZE VERTICAL POTENTIAL

Storage space is always a problem. Finding new ways to utilize missed opportunities can be challenging especially since no two spaces are identical. Focus Foodservice has an array of problem solving solutions when it comes to capitalizing on open wall spaces. Anywhere above a sink, worktable or even above a large piece of equipment can be an ideal place for more storage. Besides some of the standard wall mount brackets and shelves, we now offer the EZ-Wall modular wall storage system that can be customized to maximize your workstations' efficiencies. Getting you organized has never been so EZ.

**FOCUS FOODSERVICE**  
Call: 800.968.3918  
Fax: 800.968.4129  
Click: [orders@crowns-brands.com](mailto:orders@crowns-brands.com)  
Search: [www.crowns-brands.com](http://www.crowns-brands.com)





# Going Above and Beyond with... **EZ-WALL™ Storage Solutions**



**CROWN BRANDS**  
STORAGE AND  
TRANSPORTATION



## Create More Efficient & Productive Working Environments by Increasing the Vertical Capacity of Your Workstations.

- Grid system maximizes workstation by using vertical wall spaces.
- Increase efficiency and storage, keep everything within arms reach.
- Heavy duty commercial grade, epoxy coated grid and components.
- Comprehensive selection of components both dry and wet applications.



## Amazing transformations from underutilized workspaces to highly organized and efficient workstations.

### Before:

Limited shelf storage space could not hold enough of the essential spices or ingredients use everyday. The fabricated wood shelves were a health code risk and not easy to clean or care for. Ingredients were close, but still hard to access. No space for prep tools and materials needed to keep the kitchen running smoothly.

### After:

Chromate EZ-Wall Unit replaces shelving with easier accessibility and visibility. Modular storage and grid mounted wire baskets (second row of shelves) bring ingredients closer to prep faster and more efficiently. Now, there is more room for additional back stock. Grids allow for all utensils and gadgets to be within reach at all times. Grid mounted wire baskets (to right) become instant storage for disposal gloves, small boxed goods, etc.

# EZ-WALL™ Storage Solutions

## EZ-WAYS to Accessorize

Most components are available in Chromate & Green Epoxy (see pages 42-43 for item info).

Modular & Versatile



Watch our EZ-WALL™ installation video on our website. Just scan the QR code below.



Horizontal and vertical brackets allow you to custom build the most modular and versatile wall storage system ever. They create the secure foundation to which all the other components can be attached and re-positioned as needed.

A Spice Rack, Double “J” Hook and Plastic Bin Holder\* have recently been added to the EZ-Wall™ System to allow for even more flexibility to your wall storage needs. \*Plastic Bin Holder shown with bin from Update Int'l. Update Int'l [MOB-106 and MOB-122] bins sold separately.

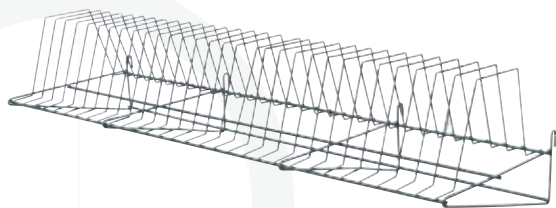

A 48" green epoxy drying rack offers a method to safely dry and store a variety of bakware, etc.



Stainless steel J hooks [single and double] snap fit to grid or shelf trusses.

Our new universal design bin holder can be adjusted to accommodate any standard plastic parts bin and hold it secure and level.



Spice Rack is perfect size for holding commercial spice containers. Can also be used to conveniently store bottles or cans for easy access.



Utility holder hook [left] fastens to wire grid to hold plastic utility basket. Featured basket shown is from Update Int'l [#FLT-C4P] sold separately.

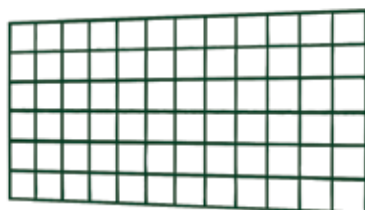

Wire grids can be hung from vertical brackets (above), hung by smaller brackets (shown on page to right) or mounted directly to wall with 4 to 6 hooks.



Peg hooks are designed to wrap around grid wires to provide a more stable fixture for items to hang from.



Pronged bottle drying fixture fastens to wire grid. Long prongs hold plastic serving bottles, short prongs hold dispensing caps, etc.

Full listing of EZ-WALL™ components on pages 42 and 43.



**CROWN BRANDS**  
**STORAGE AND TRANSPORTATION**

Our #10 Can Holder designed to mount on to the wire grid and accommodates 4 cans.



Single and double shelf supports in green epoxy and chromate finishes mount to the vertical brackets to create a platform for adding shelves. See page 42 for product specifications.



[fig. 1]

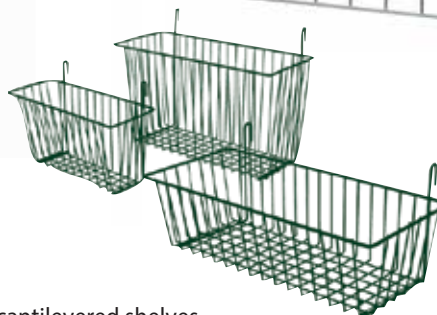

Wire mounted baskets are available in both chromate and green epoxy. They can hang on a wire grid or off our standard shelves. 3 sizes to help organize or hold almost anything.

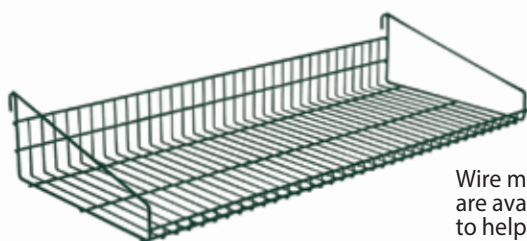

Wire mounted cantilevered shelves are available in 2 finishes and 3 sizes to help keep inventory within arms reach.

Wire mounted shelves mount directly to the grids. This eliminates the need for vertical brackets, shelf supports and additional shelves; however, this style of shelving may not have the same weight capacity as those installed with the components listed above.

Various specialized brackets [fig. 2-4, below] are available to retro-fit some of our most popular items to the horizontal mounts that the standard vertical brackets cannot. For example, the bracket [shown in fig.1 and fig. 4] has been designed to hang a wire grid or our utensil rack directly from the horizontal bracket.

Additional retro-fit brackets [shown below] can accommodate other existing items currently in our assortment. The advantage to using these brackets with your EZ-Wall systems is that you are no longer mounting shelving directly to the wall, so you can move or adjust the position of your shelving depending on your needs.



FWMAFWSAL1224CH used with our aluminum and stainless steel K/D shelf kits.

[fig. 2]



FWMAFWPS13CH used with post mount shelving.

[fig. 3]



FWMGBL used to hang wire grids or existing utensil rack.

[fig. 4]

# EZ-WALL™ Storage Solutions [Brackets and Baskets]

## Horizontal Mounting Brackets [Chromate or Green Epoxy]

Chromate Finish Item #	Green Epoxy Finish Item #	Horizontal Mounting Bracket Dimensions	Horizontal Mounting Bracket Dimensions		Case
			(in.)	(cm)	
FWMBKT12CH	FWMBKT12GN	12" Horizontal Bracket	12" x 0.66" x 1.75"	(30.5 x 1.7 x 4.4 cm)	12
FWMBKT18CH	FWMBKT18GN	18" Horizontal Bracket	18" x 0.66" x 1.75"	(45.7 x 1.7 x 4.4 cm)	12
FWMBKT36CH	FWMBKT36GN	36" Horizontal Bracket	36" x 0.66" x 1.75"	(91.4 x 1.7 x 4.4 cm)	6
FWMBKT48CH	FWMBKT48GN	48" Horizontal Bracket	48" x 0.66" x 1.75"	(122.0 x 1.7 x 4.4 cm)	6
FWMBKT60CH	FWMBKT60GN	60" Horizontal Bracket	60" x 0.66" x 1.75"	(152.4 x 1.7 x 4.4 cm)	6

FWMBKT60CH



FWMVB17GN

## Vertical Brackets [Chromate or Green Epoxy]

Chromate Finish Item #	Green Epoxy Finish Item #	Vertical Bracket Dimensions	Vertical Bracket Dimensions		Case
			(in.)	(cm)	
FWMVB17CH	FWMVB17GN	16" Vertical Bracket	16" x 2.375" x 1.75"	(40.6 x 6.0 x 4.4 cm)	12
FWMVB31CH	FWMVB31GN	31" Vertical Bracket	31" x 2.375" x 1.75"	(79.3 x 6.0 x 4.4 cm)	12
FWMVB41CH	FWMVB41GN	44" Vertical Bracket	44.5" x 2.375" x 1.75"	(113 x 6.0 x 4.4 cm)	6

FWMVB31GN

FWMVB41GN

## Single Shelf Mounts [Chromate or Green Epoxy]

Chromate Finish Item #	Green Epoxy Finish Item #	Single Shelf Mount Dimensions	Single Shelf Mount Dimensions		Case
			(in.)	(cm)	
FWMSB14CH	FWMSB14GN	Single Mount for 14" Shelf	16.5" x 9" x 1.5"	(41.9 x 22.8 x 3.1 cm)	16
FWMSB18CH	FWMSB18GN	Single Mount for 18" Shelf	20.25" x 9" x 1.5"	(51.4 x 22.8 x 3.1 cm)	8
FWMSB21CH	FWMSB21GN	Single Mount for 21" Shelf	21" X 6" X 2"	(53.0 x 15.3 x 5.1 cm)	16
FWMSB24CH	FWMSB24GN	Single Mount for 24" Shelf	26.5" x 9" x 1.5"	(67.31 x 22.8 x 3.1 cm)	16

FWMSB18CH/GN

FWMDB14CH/GN

## Double Shelf Mounts [Chromate or Green Epoxy]

Chromate Finish Item #	Green Epoxy Finish Item #	Double Shelf Mount Dimensions	Double Shelf Mount Dimensions		Case
			(in.)	(cm)	
FWMDB14CH	FWMDB14GN	Double Mount for 14" Shelf	16.5" x 9" x 1.5"	(41.9 x 22.8 x 3.1 cm)	16
FWMDB18CH	FWMDB18GN	Double Mount for 18" Shelf	20.25" x 9" x 1.5"	(51.4 x 22.8 x 3.1 cm)	16
FWMDB21CH	FWMDB21GN	Double Mount for 21" Shelf	23.25" x 9" x 1.5"	(59.0 x 22.8 x 3.1 cm)	16
FWMDB24CH	FWMDB24GN	Double Mount for 24" Shelf	26.5" x 9" x 1.5"	(67.31 x 22.8 x 3.1 cm)	16

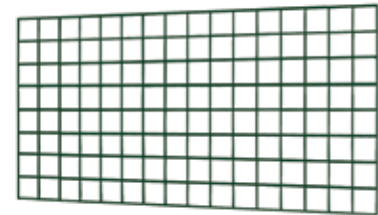

FWMG2436GN

## Wire Grids [Chromate or Green Epoxy]

Chromate Finish Item #	Green Epoxy Finish Item #	Wire Grid Dimensions	Wire Grid Dimensions		Case
			(in.)	(cm)	
FWMG1836CH	FWMG1836GN	18" x 36" Wire Grid	18.25" x 36.25" x 0.5"	(46.3 x 92.0 x 1.3 cm)	6
FWMG2424CH	FWMG2424GN	24" x 24" Wire Grid	24.25" x 24.25" x 0.5"	(61.6 x 61.6 x 1.3 cm)	4
FWMG2436CH	FWMG2436GN	24" x 36" Wire Grid	24.25" x 36.25" x 0.5"	(61.6 x 92.0 x 1.3 cm)	4
FWMG2448CH	FWMG2448GN	24" x 48" Wire Grid	24.25" x 48.25" x 0.5"	(61.6 x 122.5 x 1.3 cm)	4
FWMG3036CH	FWMG3036GN	30" x 36" Wire Grid	30.25" x 36.25" x 0.5"	(76.8 x 92.0 x 1.3 cm)	4

## Grid Mounted Wire Baskets [Chromate or Green Epoxy]

Chromate Finish Item #	Green Epoxy Finish Item #	Wire Basket Dimensions	Wire Basket Dimensions		Case
			(in.)	(cm)	
FWMBSKT1357CH	FWMBSKT1357GN	Wire Basket	13.5" x 5" x 7"	(34.3 x 12.7 x 17.7 cm)	24
FWMBSKT1377CH	FWMBSKT1377GN	Wire Basket	17.5" x 7.5" x 5"	(44.4 x 19.0 x 12.7 cm)	12
FWMBSKT17710CH	FWMBSKT17710GN	Wire Basket	17.5" x 7.5" x 10"	(44.4 x 19.0 x 25.4 cm)	12

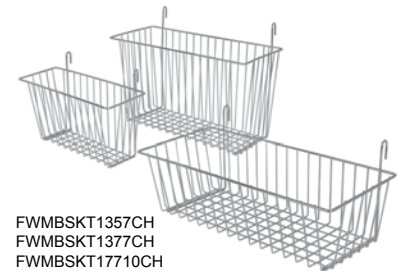

FWMBSKT1357CH  
FWMBSKT1377CH  
FWMBSKT17710CH

## Grid Mounted Cantilever Wire Shelves [Chromate or Green Epoxy]

Chromate Finish Item #	Green Epoxy Finish Item #	Bracket Size (width/length)	Bracket Size (width/length)		Case
			(in.)	(cm)	
FWMGMS3019CH	FWMGMS3019GN	Cantilever Shelf	29" x 19" x 6"	(73.6 x 48.2 x 15.2 cm)	4
FWMGMS3619CH	FWMGMS3619GN	Cantilever Shelf	35" x 19" x 6"	(88.9 x 48.2 x 15.2 cm)	4
FWMGMS4819CH	FWMGMS4819GN	Cantilever Shelf	47" x 19" x 6"	(119.3 x 48.2 x 15.2 cm)	4

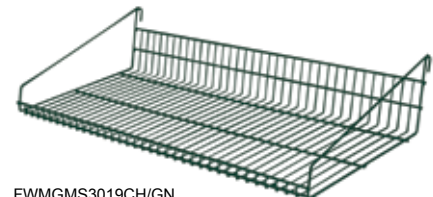

FWMGMS3019CH/GN

# EZ-WALL™ Storage Solutions [Components and Kit]



**CROWN BRANDS**  
STORAGE AND  
TRANSPORTATION

## Grid Mounted Storage Accessories [Chromate]

Item #	Description	(in.)	Dimensions (cm)	Case
FWMSPICERACKCH	Spice Rack	23" x 4.25" x 6"	(58.4 x 10.7 x 15.2 cm)	6
FWMCRCH	#10 Can Rack	15" x 8" x 10.5"	(38.1 x 20.3 x 26.6 cm)	4
FWMPEGHOOKCH	Peg Hooks (12 per pack)	7.25" x 1.25" x 5.25"	(18.4 x 15.2 x 13.3 cm)	20

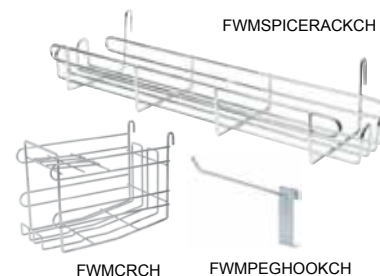

## Grid Mounted Storage & Drying Accessories [Green Epoxy]

Item #	Description	(in.)	Dimensions (cm)	Case
FWMCUHG	Plastic Utensil Holder	5.5" x 2.5" x 7.25"	(13.9 x 6.3 x 18.4 cm)	8
FWMBHR6GN	Bottle Drying Rack	8" x 12" x 3.75"	(20.3 x 30.4 x 9.52 cm)	12
FWMPEGHOOKGN	Peg Hooks (12 per pack)	7.25" x 1.25" x 5.25"	(18.4 x 15.2 x 13.3 cm)	20
FWMTDRGN	Drying/Storage Rack	46.5" x 15" x 11"	(118.1 x 38.1 x 27.9 cm)	2

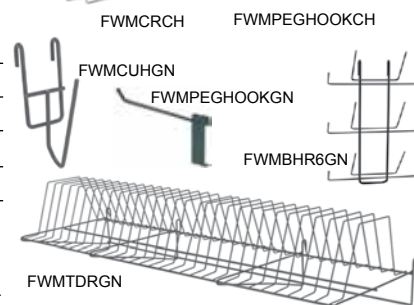

## Hooks, Brackets & Accessories [Stainless Steel]

Item #	Description	Bracket Size (width/length) (in.)	(cm)	Case
FWMHOOSS	J Hooks (12 per pack)	3.5" x 0.5" x 1.25"	(8.89 x 1.27 x 3.17 cm)	20
FWMHOOSS2PK3	Double J Hooks (3 per pack)	2" x 3.5" x 2"	(5.08 x 8.89 x 5.08 cm)	100
FWMBHSS6	Bin Holders (6 per pack)	3.5" x 2.5" x 1"	(8.89 x 6.35 x 2.54 cm)	20
FWMB6SS	Direct Wall Mounts (6 per pack)	2" x 1" x 1.5"	(5.08 x 2.54 x 3.81 cm)	40
FWMGBL*	Grid Brackets (2 per pack)	3.5" x 5.5" x 1.75"	(8.89 x 13.97 x 4.44 cm)	24
FWMAFWSAL1224CH	Post Brackets (2 per pack)	18" x 4" x 1.25"	(45 x 10.1 x 3.17 cm)	12
FWMAFWPS13CH	K/D Shelf Brackets (2 per pack)	4.5" x 3.5" x 3.75"	(11.5 x 8.9 x 9.4 cm)	24



\*Replaces FWMAFUR1824CHSS

## WE'VE MADE IT EASIER TO CASH & CARRY.

Our basic EZ-WALL kit that will help increase storage and work flow efficiencies in any prep or wash station application. The 24" x 24" green epoxy grids along with various hooks and baskets can be used independently of the horizontal and vertical brackets by using our direct wall hooks. Or mount them partially anywhere to help organize your work spaces as well as promote cleaner storage solutions for both prep and wash areas in versatile and modular ways.

This **EZ-WALL™ Kit** Includes:

- (8) Stainless Steel Direct Wall Mounting Brackets
- (6) Green Epoxy Coated Peg Hooks
- (6) Stainless Steel "J" Hooks
- (2) Green Epoxy Coated 24" x 24" Grids
- (1) Green Epoxy Coated 13.5" x 5" x 7" Basket
- (1) Green Epoxy Coated 17.5" x 7.5" x 7" Basket

Full color packaging illustrates how this unit can be used for prep or as part of a wash station. Detailed images demonstrate the components being used in various configurations.



Item #	Description	Case
FWMKIT1	EZ-WALL Prep and Dry Kit (2) 24" x 24" (60.96 x 60.96 cm) grids & accessories	1

# Stainless Steel Pot & Pan and Utensil Racks

Tabs allow you to add 14" wide shelf.

**Heavy-Duty**

Providing Durable and Efficient Ways to Dry & Store Your Pots and Pans.

**Stainless Steel Pot and Pan Rack**

- Space Saving Design with three fully welded tubes tiered to maximize storage capacity while minimizing the overall space required.
- Economical alternative to expensive custom fabricated designs.
- Three sizes to choose from 36", 48" or 60" length, each will accommodate a 14" wide shelf.
- Fast, easy installation that holds up to 400lbs of weight\*.
- Keep your pots and pans within arms reach for efficient drying and storage needs.

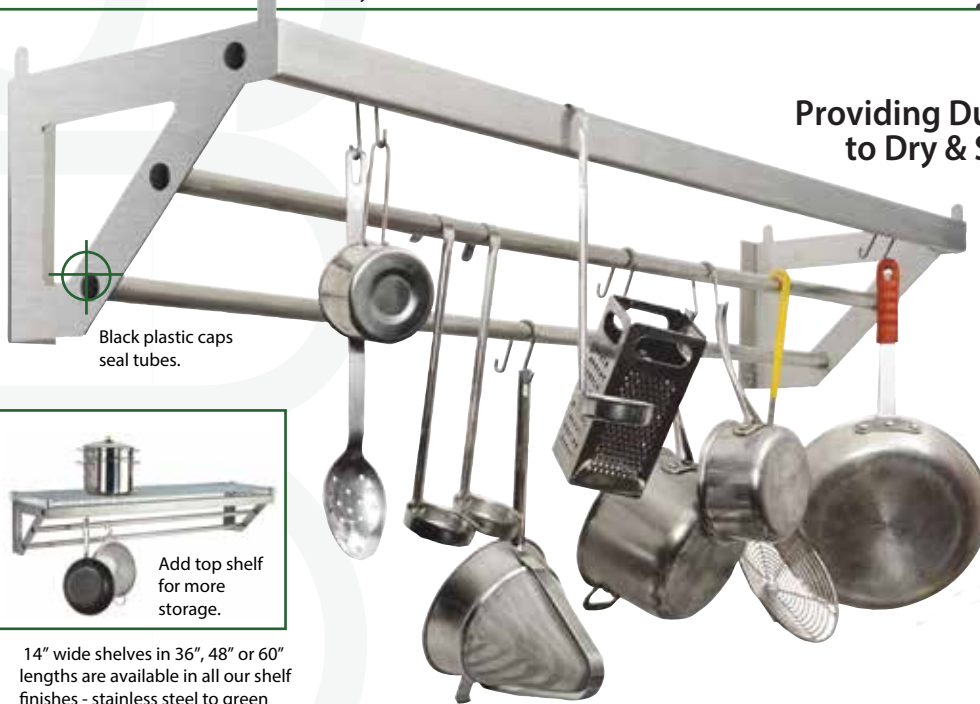

Black plastic caps seal tubes.



Add top shelf for more storage.

14" wide shelves in 36", 48" or 60" lengths are available in all our shelf finishes - stainless steel to green epoxy, chromate to fps-plus. Finishes for whatever application or look you want to achieve.

Item#	Size (width/length)	Hook (qty)	Case
FWMPR36SS	14" x 36" (35.5 x 91.4 cm)	4	1
FWMPR48SS	14" x 48" (35.5 x 122.0 cm)	6	1
FWMPR60SS	14" x 60" (35.5 x 152.4 cm)	8	1
PRHOOK	3" (7.6 cm)	2 per pkg	50 pkgs

**Standard - Duty**

**Stainless Steel Wall-Mounted Utensil Rack**

Versatile rack can be installed virtually anywhere within minutes. Provides easy organization and quick access to kitchen utensils.

- Heavy gauge 18-8 stainless steel construction.
- Includes 20 each 2 3/4" (7.0 cm) stainless steel hooks to hang a variety of utensils.
- Dimensions – 18" x 24" x 3" (45.7 x 61.0 x 7.6 cm).
- For additional hooks order item # FURHOOKSS.
- Mounting brackets included.



Item	# Description	Case
FUR1824CHSS	18-8 stainless steel utensil rack w/20 hooks. 18" x 24" x 3" (45.7 x 61.0 x 7.6 cm)	6
FURHOOKSS	2 3/4" (7.0 cm) stainless steel hooks. 20 per pkg.	60

Shipped in Full Color Trilingual Merchandising Cartons

# Wall Shelf Kits [Stainless Steel & Aluminum]



**CROWN BRANDS**  
STORAGE AND  
TRANSPORTATION



## Stainless Steel K/D Wall Shelf Kits

Durable 18 gauge stainless steel construction. Frees up valuable counter space. 1.5" downward front edge and turned up back edge. Includes 2 brackets and 1 shelf. Mounting hardware not included..

Item #	Size (width/length)	Case
FWSSS1224	12" x 24" (30.5 x 61.0 cm)	1
FWSSS1236	12" x 36" (30.5 x 91.4 cm)	1
FWSSS1248	12" x 48" (30.5 x 122.0 cm)	1
FWSSS1260	12" x 60" (30.5 x 152.4 cm)	1

Shipped in Full Color Trilingual Merchandising Cartons



FWSAL1224

## Aluminum K/D Wall Shelf Kits

Frees up valuable counter space. Durable 16 gauge aluminum construction. Marine edge to keep spills on the shelf. 1.5" downward front edge and turned up back edge. Includes 2 brackets and 1 shelf. Mounting hardware not included.

Item #	Size (width/length)	Case
FWSAL1224	12" x 24" (30.5 x 61.0 cm)	1
FWSAL1236	12" x 36" (30.5 x 91.4 cm)	1
FWSAL1248	12" x 48" (30.5 x 122.0 cm)	1
FWSAL1260	12" x 60" (30.5 x 152.4 cm)	1



FWSAL1236



Shipped in Full Color Trilingual Merchandising Cartons

# Wall Mount Kits and Direct Wall Mount Brackets

Solid Stainless



## Wall Shelf Kits - Green Epoxy Coated

For your convenience, we have packaged two single wall brackets, a heavy-duty shelf, and 4 chromate shelf caps in a single pack. All the features and benefits of our heavy-duty wall brackets. Choose from four popular shelf sizes. Hardware to mount brackets to wall is NOT included [Please select according to type of wall].



Merchandising Cartons  
Shipped in Full Color Trilingual

Item #	Description	Case
FWS1436G	Kit includes 2 each 14" (35.5 cm) single wall brackets, 1 each 14" x 36" (35.5 cm x 91.4 cm) shelf, & 4 each chromate shelf caps	1
FWS1448G	Kit includes 2 each 14" (35.5 cm) single wall brackets, 1 each 14" x 48" (35.5 cm x 122.0 cm) shelf, & 4 each chromate shelf caps	1
FWS1836GN	Kit includes 2 each 18" (45.7 cm) single wall brackets, 1 each 18" x 36" (45.7 cm x 91.4 cm) shelf, & 4 each chromate shelf caps	1
FWS1848GN	Kit includes 2 each 18" (45.7 cm) single wall brackets, 1 each 18" x 48" (45.7 cm x 122.0 cm) shelf, & 4 each chromate shelf caps	1

### Direct Mount Wall Brackets

Brackets are securely welded to the mounting plate for greater durability. Because mounting plate is welded to the bracket, it is much easier to align and install to a wall. The back of the shelf is within a fraction of an inch from the wall to save space. Chromate shelf caps included to cover openings in tops of shelves. Available in chromate or green epoxy coated.

Use single brackets at shelf ends and double brackets for adjoining shelves. Hardware to mount brackets to wall is NOT included.

Please select according to type of wall.

Order shelves separately.

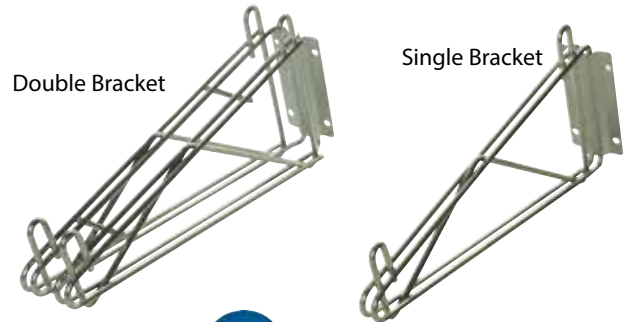

Chromate Item #	Green Epoxy Coated		Case
	Item #	Description	
FWB12SCH	FWB12SGN	12" (30.5 cm) Single	2
FWB14SCH	FWB14SG	14" (35.5 cm) Single	2
FWB18SCH	FWB18SG	18" (45.7 cm) Single	2
FWB21SCH	FWB21SGN	21" (53.0 cm) Single	2
FWB24SCH	FWB24SGN	24" (61.0 cm) Single	2
FWB12DCH	FWB12DGN	12" (30.5 cm) Double	2
FWB14DCH	FWB14DG	14" (35.5 cm) Double	8
FWB18DCH	FWB18DG	18" (45.7 cm) Double	8
FWB21DCH	FWB21DGN	21" (53.0 cm) Double	8
FWB24DCH	FWB24DGN	24" (61.0 cm) Double	8

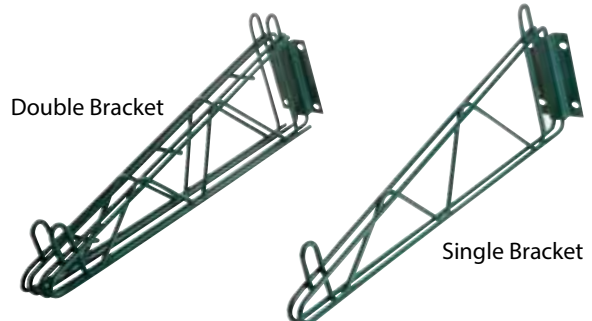



# Wall Mounted Shelving [Posts and Brackets]



**CROWN BRANDS**  
STORAGE AND  
TRANSPORTATION

## Wall Mounted Shelving

Take advantage of the extra storage space walls offer. Ideal for storing items conveniently overhead or above sinks, work tables, counters, or desks. Accommodates all 12", 14", 18", 21", and 24" (30.5, 35.5, 45.7, 53.0, and 61.0 cm) wide shelves. Wire lugs on brackets fit corner collar openings on shelves. Chromate shelf caps are included to cover openings in tops of shelves for greater sanitation. Choose from single or double supports. Double supports are used for continuous runs of shelving. Single supports are used at each end of a shelf. Available in green epoxy coated for wet or dry environments. Chromate finish is for dry environments.

## Post-Type Wall Mounts

Post-type mounting system can meet your exact needs for wall shelving. Posts and supports are available to hold anything from a single small shelf to many tiers of shelving running continuously along a wall.

Posts have grooves along their entire length at 1" (25mm) intervals for fast and secure assembly. Tapered plastic split-sleeves lock around any groove, and matching taper in opening of shelf collar creates secure positioning. Shelf supports and shelves can be positioned or repositioned on the post in 1" (25mm) increments. Chromate shelf caps are included to cover openings in tops of shelves. Available in chromate or green epoxy coated finish.

Each post assembly includes one post and 2 mounting (top and bottom). One intermediate bracket is supplied with 33" (83.8 cm) posts and two are supplied with 54" & 63" (137.0 & 160.0 cm) posts for greater security. Hardware to mount brackets to wall is NOT included. Please select according to type of wall. Order shelves separately.

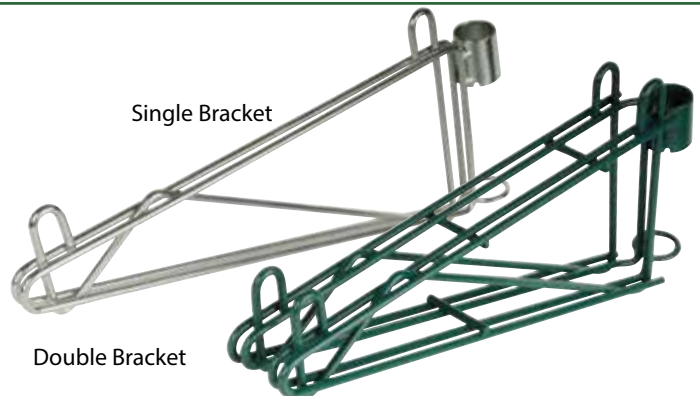
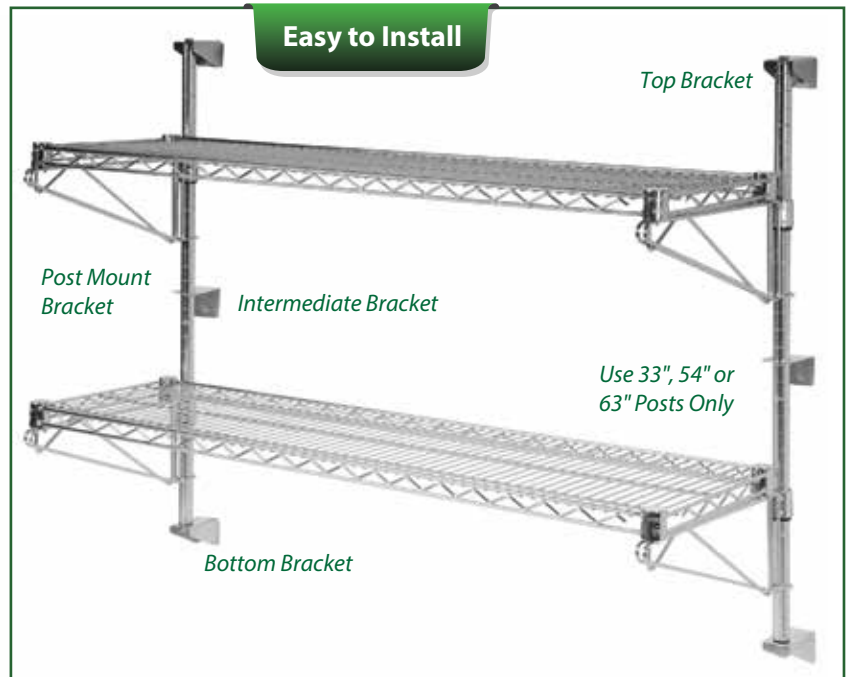

## Posts

Chromate Item #	Green Epoxy Coated Item #	Description	Case
FWPS13CH	FWPS13GN	13" (33.0 cm) Wall post	2
FWPS24CH	FWPS24GN	24" (61.0 cm) Wall post	2
FWPS33CH	FWPS33GN	33" (83.8 cm) Wall post	2
FWPS54CH	FWPS54GN	54" (137.0 cm) Wall post	2
FWPS63CH		63" (160.0 cm) Wall post	2

## Post Mount Brackets

Chromate Item #	Green Epoxy Coated Item #	Description	Case
FPMB14SCH	FPMB14SGN	14" (35.5 cm) Single post mount bracket	2
FPMB18SCH	FPMB18SGN	18" (45.7 cm) Single post mount bracket	2
FPMB21SCH		21" (53.0 cm) Single post mount bracket	2
FPMB24SCH	FPMB24SGN	24" (61.0 cm) Single post mount bracket	2
FPMB14DCH	FPMB14DGN	14" (35.5 cm) Double post mount bracket	8
FPMB18DCH	FPMB18DGN	18" (45.7 cm) Double post mount bracket	8
FPMB21DCH		21" (53.0 cm) Double post mount bracket	8
FPMB24DCH	FPMB24DGN	24" (61.0 cm) Double post mount bracket	8

## Extra Brackets for Wall Posts

Chromate Item #	Green Epoxy Coated Item #	Description	Case
FWPBKTCH	FWPBKTGN	Additional top or bottom bracket (2 pieces)	24
FWPIBCH	FWPIBGN	Additional intermediate bracket	24



Chromate Shelf Caps available to fill shelf corner openings. (see accessories).

FCSC

# FOCUS

**FOODSERVICE**

ACCESSORIES: 48-58

## GET READY TO ACCESSORIZE.

You bought the shelves and the posts, maybe a cart or a kit.

Now, it's time to **CUSTOMIZE**.

we have the peg hooks and baskets.

Maybe **PRIORITIZE**? Shelf dividers and labels with get things in order.

Need casters for a new fryer or a heavy-duty piece of equipment, but your budget is tight...

We can help you **MOBILIZE** for up to 50% less than the OEM dealer's price.

We have all this and more in store...

### FOCUS FOODSERVICE

Call: 800.968.3918

Fax: 800.968.4129

Click: [orders@crowns-brands.com](mailto:orders@crowns-brands.com)

Search: [www.crown-brands.com](http://www.crown-brands.com)



# Specialty Shelving Accessories



**CROWN BRANDS**  
STORAGE AND  
TRANSPORTATION

Make the most use of your shelving for a more efficient, safer and convenient workflow.



## Green Epoxy Wire Drying Rack Shelves

The perfect product for holding almost any kind of tray for drying or storage. No need for additional attachments, these are complete shelves!

Two shelf styles available:

15 drying slots to accommodate deeper bakeware and cutting boards  
35 drying slots for standard sheet pans, shallow pans, etc.

Item #	Description	Case
FTS2448815GN	24" x 48" (61.0 x 122.0 cm), 15 slots	2
FTS2448835GN	24" x 48" (61.0 x 122.0 cm), 35 slots	2

## Wire Tray Modules - Green Epoxy Coated

The perfect product for holding almost any kind of tray for drying or storage. Modules simply attach to shelves by zip ties (included with each module). Can be easily removed for cleaning. Combine modules to fit entire lengths of popular sized shelves. Width: 15 1/2" (39.4 cm). Height: 8" (20.3 cm).

Item #	Clearance	Length	Tray Capacity	Case
FFTM188GN	1 3/4" (4.5 cm)	16 1/2" (41.9 cm)	8	4
FFTM2412GN	1 3/8" (4.1 cm)	22 1/2" (57.2 cm)	12	4
FFTM184GN	3 13/16" (9.7 cm)	16 1/2" (41.9 cm)	4	4
FFTM246GN	3 1/8" (8.8 cm)	22 1/2" (57.2 cm)	6	4



## Wire Can Rack

Get more out of your shelving and proper inventory rotation with this front-loading, front dispensing can rack. Holds 8 each #10 cans or 12 each #5 cans. Fits 24" (61.0 cm) wide shelves. Chromate finish. 24 13/16" x 7 7/8" x 13 5/16" H (63.1 x 20.0 x 33.8 cm)

Item #	Description	Case
FFCR10CH	Wire can rack, for 24" wide shelves, holds 8 ea #10 cans, chromate finish	1

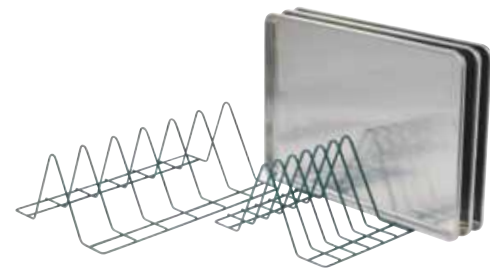

Tray modules can be combined and attached over the length of most wire shelves. The chart below will assist in taking the best advantage of your shelving space.

Shelf Length	FFTM18	FFTM24
24" (61.0 cm)	0	1
36" (91.4 cm)	2	0
42" (106.6 cm)	1	1
48" (122.0 cm)	0	2
54" (137.0 cm)	3	0
60" (152.4 cm)	2	1
72" (182.9 cm)	0	3



## Tray Slide Module - Green Epoxy Coated

This tray slide module offers tremendous flexibility and reduces costs. Manufacturer installed pan supports in a reach-in or under-counter refrigerator reduce capacity. The FTSM8GN can be installed on a shelf to provide quick and easy storage for up to 8 pans. Tray slide can be removed to provide bulk storage. Tray slide can be turned on its side to be used to hold and dry cutting boards & sheet pans. Constructed from heavy duty wire with a green epoxy coating. Comes with 4 nylon cable ties to secure to shelves for greater stability. Clearance between slides is 1 1/4" (3.2 cm). 12 year warranty against naturally occurring rust.

Item #	Description	Size (width/length/height)	Case
FTSM8GN	Tray slide module	22 1/2" x 19" x 14" (57.2 x 48.3 x 35.6 cm)	1



## Wire Tray Slides

Allows much more efficient use of shelf space. Mount slides to the desired width to accommodate sheet pans, hotel pans, or any other trays. Slides mount to shelves above and below unit with easy to assemble hardware. Holds 12 trays. Available in chromate or green epoxy coated finish. For 18", 21", and 24" 45.7, 53.0, and 61.0 cm) wide shelving. 21 1/2" (54.6 cm) high, 13 1/2" (34.3 cm) wide. Spacing between slides 1 1/2" (3.8 cm). Width of each slide 2 1/2" (6.4 cm). Includes left and right slide plus mounting hardware.

Item #	Description	Case
FWTS12CH	Wire tray slides, capacity 12 trays, chromate finish	1
FWTS12GN	Wire tray slides, capacity 12 trays, green epoxy	1

# Shelf Dividers and Ledges



**NSF APPROVED:** These commercial rated items are ideal just about any storage application. The chromate and black epoxy accessories are only recommended for dry or display usage. Our green epoxy items can be used in any environment, wet or dry...even coolers.

## Shelf Dividers

Keep your shelves well organized and orderly with these 8" (20.3 cm) high, pressure fit dividers. Order by shelf width. There are two different versions available based on the shelf style. One version is made for black or chromate wire shelves, the other (green epoxy) divider is constructed to accommodate the thickness of FPS-Plus™ polymer shelf panel.



This shelf divider style was made for chromate wire finish or black epoxy wire shelves.



This shelf divider style was made to accommodate the thickness of the FPS-Plus™ polymer shelf panel.

Chromate Item #	Black Epoxy Coated Item #	Description	Case
	FSD14BK	14" x 8" h (35.5 x 20.3 cm)	4
FSD18C	FSD18BK	18" x 8" h (45.7 x 20.3 cm)	4
	FSD21BK	18" x 8" h (53.0 x 20.3 cm)	4
FSD24C	FSD24BK	24" x 8" h (61.0 x 20.3 cm)	4

Green Epoxy Coated Item #	Description	Case
FSD188FPS	18" x 8" h (53.0 x 20.3 cm)	4
FSD248FPS	24" x 8" h (61.0 x 20.3 cm)	4

## Shelf Ledges



Promote safety in your operation by using these heavy-duty ledges to keep items from protruding or falling from shelves. Ledges fit back or sides of shelving units. Ledges can be stacked on top of each other for additional height. Available for chromate and black epoxy or FPS-PLUS™ shelves.

Chromate Item #	Black Epoxy Coated Item #	Description	Case
	FL144BK	14" x 4" h (35.5 x 10.1 cm)	4
FL184C	FL184BK	18" X 4" h (45.7 x 10.1 cm)	4
FL214C	FL214BK	21" X 4" h (53.0 x 10.1 cm)	4
FL244C	FL244BK	24" x 4" h (61.0 x 10.1 cm)	4
FL364C	FL364BK	36" x 4" h (91.4 x 10.1 cm)	4
FL484C	FL484BK	48" x 4" h (121.9 x 10.1 cm)	2
FL604C	FL604BK	60" x 4" h (152.4 x 10.1 cm)	2

Green Epoxy Coated Item #	Description	Case
FSL184FPS (side)	18" X 4" h (45.7 x 10.1 cm)	4
FSL214FPS (side)	21" X 4" h (53.0 x 10.1 cm)	4
FSL244FPS (side)	24" x 4" h (61.0 x 10.1 cm)	4
FBL304FPS (back)	30" x 4" h (61.0 x 10.1 cm)	4
FBL364FPS (back)	36" x 4" h (91.4 x 10.1 cm)	4
FBL484FPS (back)	48" x 4" h (121.9 x 10.1 cm)	4
FBL604FPS (back)	60" x 4" h (152.4 x 10.1 cm)	4

# Shelving Unit Accessories



**CROWN BRANDS**  
STORAGE AND  
TRANSPORTATION



## Snap-Under Truss Shelf Label Holders

Black Plastic Shelf labels snap under front truss, fits most standard shelves. Black plastic labels are available in 3" (7.6 cm) or 6" (15.2 cm) lengths. 1 1/4" (3.2 cm) openings. Holds most commercial 1 1/4" (3.2 cm) labels. Packed 4 per package. \*Paper labels not included.

Item #	Description	Case
FUTL3BK	3" (7.6 cm), 4 per pkg	50
FUTL6BK	6" (15.2 cm), 4 per pkg	50



## Snap-On Plastic Shelf Label Holders

Plastic labels in black or clear are available in 3" (7.6 cm) or 6" (15.2 cm) lengths. 1 1/4" (3.2 cm) openings. Shelf labels snap on to front of shelves. Holds most commercial 1 1/4" (3.2 cm) labels. Packed 4 per package. \*Paper labels not included.

Item #	Description	Case
FSHELF3B	3" (7.6 cm) Black, 4 per pkg	50
FSHELF6B	6" (15.2 cm) Black, 4 per pkg	50
FSHELF3CL	3" (7.6 cm) Clear, 4 per pkg	50
FSHELF6CL	6" (15.2 cm) Clear, 4 per pkg	50

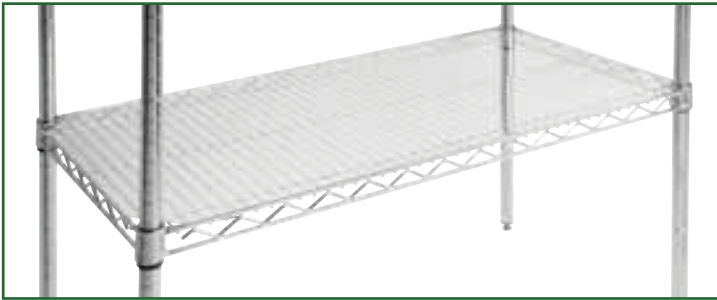

FPSL24CL inlay on FF24GC shelf (shelf sold separately).  
\* More information on page 5.

## Clear Shelf Inlays & New Corner Shelf Inlays

Clear plastic mats provide greater stability for items on shelves, while still letting light through. Wide selection of sizes including three new inlays for corner shelves [see page 5 for more details].

Item #	Description	Case	Item #	Description	Case
FPSL1424CL	14" x 24" (35.5 x 61.0 cm) Shelf inlay	4	FPSL2148CL	21" x 48" (53.0 x 122.0 cm) Shelf inlay	4
FPSL1436CL	14" x 36" (35.5 x 91.4 cm) Shelf inlay	4	FPSL2160CL	21" x 60" (53.0 x 152.4 cm) Shelf inlay	4
FPSL1448CL	14" x 48" (35.5 x 122.0 cm) Shelf inlay	4	FPSL2436CL	24" x 36" (61.0 x 91.4 cm) Shelf inlay	4
FPSL1460CL	14" x 60" (35.5 x 152.4 cm) Shelf inlay	4	FPSL2448CL	24" x 48" (61.0 x 122.0 cm) Shelf inlay	4
FPSL1836CL	18" x 36" (45.7 x 91.4 cm) Shelf inlay	4	FPSL2460CL	24" x 60" (61.0 x 152.4 cm) Shelf inlay	4
FPSL1848CL	18" x 48" (45.7 x 122.0 cm) Shelf inlay	4	FPSL18CL*	18" (45.7mm) Corner Shelf inlay	4
FPSL1860CL	18" x 60" (45.7 x 152.4 cm) Shelf inlay	4	FPSL21CL*	21" (53.0mm) Corner Shelf inlay	4
FPSL2136CL	21" x 36" (53.0 x 91.4 cm) Shelf inlay	4	FPSL24CL*	24" (60.0mm) Corner Shelf inlay	4

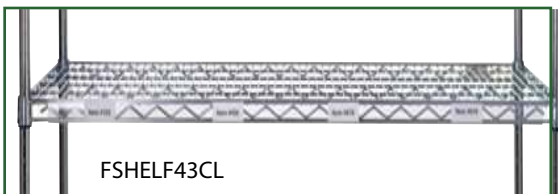

## Snap-On Clear Shelf Label Holders for 48" & 60" (122.0 & 152.4 cm) Shelves

1 1/4" (3.2 cm) openings provide an easy way to identify contents on shelves. Shelf labels snap on to front of shelves. 43" (109.2 cm) model fits on 48" (122.0 cm) long shelves and 54" (137.0 cm) model fits on 60" (152.4 cm) long shelves. Holds most commercial 1 1/4" (3.2 cm) labels. \*Paper labels not included.

Item #	Description	Case
FSHELF43CL	43" (109.2 cm), fits 48" (122.0 cm) long shelves	12
FSHELF54CL	54" (137.0 cm), fits 60" (152.4 cm) long shelves	12
FSHELF54CL	68" (172.72 cm), fits 72" (182.88 cm) long shelves	12

# Shelving Unit Accessories [For Posts or Shelves]

## S Hooks



93333 93333GN 93333BK

Use to eliminate 2 posts per adjacent unit. Two hooks required per shelf. Chromate, green, or black epoxy coated. Packed 2 per package.

## U Clamps



FPSSH

Use to eliminate 2 posts per adjacent unit. Two hooks required pershelf. Heavy guage stainless steel to connect 2 FPS-Plus polymer shelf panels and truss side-by-side. Packed 2 per package.

## Split Sleeves

FFSALSLV



Black plastic, one bag required per shelf. Packed 4 sets per package. 30058

Aluminum split sleeves for high temperature, demanding, or conductive applications. Zinc retainer rings, 4 sets per bag. 1 set required per shelf. *Requires 2" retaining [snap] pliers to install (not included).*

## Triangular Feet

FTSFZ



When additional stability is needed or to bolt units to the floor. Zinc plated. Packed 4 per package.

## Leveling Assembly

FLEVASM



Zinc die-cast post insert and zinc plated threaded bolt with gray polymer cover to protect floors. Packed 4 assemblies per package.

Gray plastic replacement covers [FPFC] are packed 4 per package.

## Caps for shelves or posts

FCSC



Chromate caps to fill shelf corner openings. Packed 4 per package.

Plastic post caps to fill top of 1" (2.5 cm) posts. Packed 4 per package.



FPLASCAP

## Universal Brackets

FWPSBGN  
FWBSBCH



Brackets provide the opportunity to secure a unit to the wall for greater safety and security. Spacing is 2" (5.1 cm) off wall. Chromate or green epoxy finish.

## Post Clamps

FXHAND18C  
FXHAND24C

Secure shelving units together for maximum strength. It is recommended to use clamps at the front and back of the unit. Chromate, black or green epoxy coated.



FPOCL  
FPOCLBK  
FPSPC

## Extended Handles



Chromate Finish For use with 18" (45.7 cm) or 24" (61.0 cm) wide shelves, Adds more maneuverability and control to mobile units. Includes 2 sets of plastic sleeves.

Item #	Description	Case
93333	S-Hook/shelf connectors - chromate finish, 2 per pkg	50
93333BK	S-Hook/shelf connectors - black epoxy coated, 2 per pkg	50
93333GN	S-Hook/shelf connectors - green epoxy coated, 2 per pkg	50
FPSSH	U-Hook/shelf connectors - green epoxy coated, 2 per pkg	96
30058	Replacement sleeves, 4 sets per pkg	12
FFSALSLV	Tapered aluminum split sleeves, 4 pair per pkg	150
FPFC	Plastic caps for post leveling feet, 4 per pkg	50
FLEVASM	Zinc plated leveling assemblies, 4 per pkg	20
FTSFZ	Triangular security feet, zinc, 4 per pkg	25

Item #	Description	Case
FCSC	Chromate shelf caps, 4 per pkg	250
FPLASCAP	Plastic post caps, 4 per pkg	50
FWPSBCH	Security bracket, chromate, 2 per pkg	24
FWPSBGN	Security bracket, green epoxy, 2 / pkg	24
FPOCL	Post clamps, chromate finish, 4 per pkg	25
FPOCLBK	Post clamps, black epoxy, 4 per pkg	25
FPSPC	Post clamps, green epoxy, 4 per pkg	25
FXHAND18C	18" (45.7 cm) extended handle	8
FXHAND24C	24" (61.0 cm) extended handle	8

# [For Posts, Shelves, Grids, Etc.]



**CROWN BRANDS**  
**STORAGE AND TRANSPORTATION**

## Baskets

Accessorize your shelving units with these wire baskets. The intergrated hooks wrap around the outer truss wires on most standard shelves\*. Allows for smaller tools, gadgets, even catalogs and equipment manuals to be stored with easy visibility and accessibility without taking up valuable shelf space. Available in chromate and green epoxy finishes in three sizes.

\* Cannot be used on corner shelves. Integrated hooks will not wrap around their double wire truss construction.

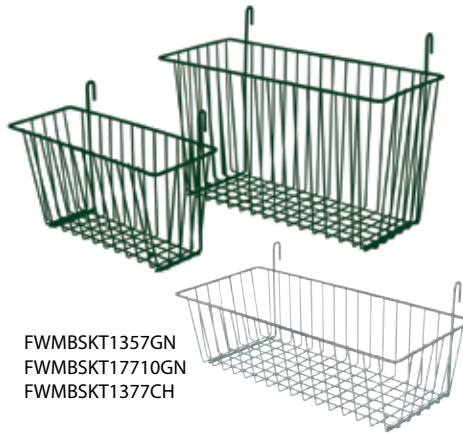

FWMBSKT1357GN  
FWMBSKT17710GN  
FWMBSKT1377CH



## Peg Hooks

FWMPEGHOOKCH  
and FWMPEGHOOKGN

Mount to a wire grid or the wire truss of a standard wire shelf\*, these peg hooks will help organize almost any tool or gadget that can be hung. Packed 12 hooks per package [all same color].

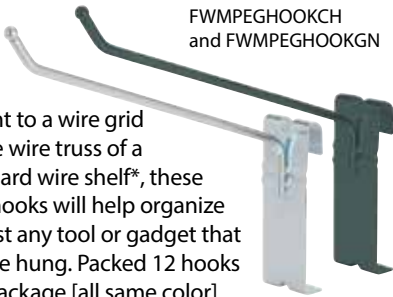

## J Hooks



FWMHOOSS and  
FWMHOOSS2PK3

Single J Hooks are packed 12 per package. Double J Hooks are packed 3 per package.

## Utility Hooks



FURHOOKS

These 2 3/4" Stainless steel hooks included with our utensil rack for standard-duty storage. They are also sold separately. Packed 20 per package.

## Spice Rack

FWMSPICERACKCH

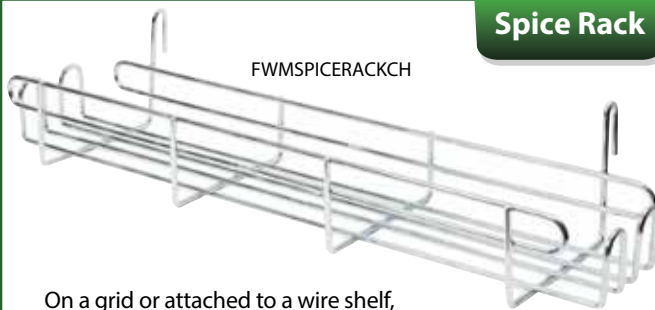

On a grid or attached to a wire shelf, this spice rack will keep your most frequently used spices and ingredients within arms reach. Deep enough to accommodate many commercial size containers.

FWMBHSS6

Not just for mounting bins to a wire grid. This well-designed bracket allows you to mount a bin even to the lip of an equipment stand. Plus the set screws can adjust the bin's angle. Update Int'l [MOB-106 and MOB-122] bins sold separately.

## Plastic Bin Holder



Chromate Finish Item #	Green Epoxy Finish Item #	Stainless Steel Item #	Description	Case
FWMBSKT1357CH	FWMBSKT1357GN		Wire Basket, 13.5" x 5" x 7" (34.3 x 12.7 x 17.7 cm)	24
FWMBSKT1377CH	FWMBSKT1377GN		Wire Basket, 17.5" x 7.5" x 5 (44.4 x 19.0 x 12.7 cm)	12
FWMBSKT17710CH	FWMBSKT17710GN		Wire Basket, 17.5" x 7.5" x 10" (44.4 x 19.0 x 25.4 cm)	12
FWMPEGHOOKCH	FWMPEGHOOKGN		Peg Hooks, 7.25" x 1.25" x 5.25" (18.4 x 15.2 x 13.3 cm), 12 per package	20
FWMSPICERACKCH			Spice Rack, Chromate Finish, 23" x 4.25" x 6" (58.4 x 10.7 x 15.2 cm)	6
		FWMHOOSS	J Hooks, Stainless Steel, 3.5" x 0.5" x 1.25" (8.89 x 1.27 x 3.17 cm), 12 per package	20
		FWMHOOSS2PK3	Double J Hooks, Stainless Steel, 2" x 3.5" x 2" (5.08 x 8.89 x 5.08 cm), 3 per package	100
		FURHOOKSS	Utility Hooks, Stainless Steel, 2 3/4" (7.0 cm), 20 per package	60
		FWMBHSS6	Leveling Plastic Bin Holder, Stainless Steel, 3.5" x 2.5" x 1" (8.89 x 6.35 x 2.54 cm), 6 /pack	20

# Universal Post Casters for Shelving

The wide selection of universal casters offered by Focus Foodservice fits most types of commercial kitchen equipment from shelving to fryers. We continue to make expensive OEM casters a thing of the past by expanding our assortment year after year.

## Universal Post Casters

**Constructed to Fit Most 1" Posts With or Without Threaded Inserts.**

- Heavy-duty polyurethane non-marking casters
- 2 each swivel and 2 each swivel with brakes
- Fits most 1" diameter shelving posts with or without threaded insert
- Secure with inner threads and/or outer set screws (use hand or screwdriver)
- 250 lb. (113 kg) per wheel capacity, 2 swivel and 2 swivel with brake



Quick & Easy • Insert post into caster collar • Rotate clockwise if threaded • Secure set screws to post by hand or with screwdriver

Item #	Description	Capacity per Caster	Case
FCAST5	Set of 4 - 5" (12.7cm) Universal Casters for Posts Threaded inside collar, 2 set screws per caster, 2 swivel casters, 2 swivel casters with brakes	220 lbs (99 kg)	4



## Caster Packaging Cash and Carry Convenience.

Every set of our casters is shipped in full color, trilingual carton. The consistent packaging makes it easy to merchandise and sell through. To make it even more convenient for the end user, our packaging features easy to read dimensional drawings of the casters on the side of the box.





# Threaded Stem and Expandable Casters



CROWN BRANDS  
STORAGE AND TRANSPORTATION



## Threaded Stem Casters

### 2.5" Universal Threaded Casters w/Brakes

- Grease-resistant polyolefin wheels with brakes
- Adds 4" (10.2 cm) of total height of equipment
- 220 lbs. (113 kg) capacity per caster

Item #	Description	Capacity per Caster	Case
FTC1213125	Set of 4 - 2.5" (6.4 cm) Universal Threaded Stem Casters w/Brakes	220 lbs (99 kg)	4

### 3" Universal Threaded Stem Casters w/Brakes

- 3" (7.6 cm) grease-resistant polyolefin wheels with brakes
- 220 lb (99 kg) weight capacity per caster

Item #	Description	Capacity per Caster	Case
FTC12133	Set of 4 - 3" (7.6 cm) Universal Threaded Casters	220 lbs (99 kg)	4

### 5" Heavy-Duty Universal Threaded Stem Casters w/Brakes

- Grease-resistant, non-marking, polyurethane wheels w/brakes
- Adds 6" (15.2 cm) of total height
- 250 lb. (113 kg) per wheel capacity

Item #	Description	Capacity per Caster	Case
FTC34105HD	Set of 4 - 5" (12.7 cm) Heavy-Duty Universal Threaded Casters with brakes 3/4" (1.9 cm) #10 x 1" (2.5 cm) Stem	250 lbs (113 kg)	4

### 5" Heavy-Duty Universal Threaded Stem Casters\*

- 2 each swivel and 2 each swivel with brakes
- Adds 6" (15.2 cm) of total height of equipment
- 250 lbs. (113 kg) per wheel capacity

\*Fits Victory® Prep Tables

Item #	Description	Capacity per Caster	Case
FTC121351	Set of 4 - 5" (12.7 cm) Heavy-Duty Universal Threaded Casters	250 lbs (113 kg)	4

### 5" Heavy-Duty Polyurethane Threaded Stem Casters

- 2 each swivel and 2 each swivel with brakes and bumpers
- Adds 6" (15.2 cm) of total height of equipment
- 200 lbs. (91 kg) per wheel capacity

Item #	Description	Capacity per Caster	Case
FTCAST5	Set of 4 - 5" (12.7 cm) threaded stem casters (2 swivel/2 swivel brake) & bumpers	200 lbs (91 kg)	4
FTCAST5B	Individual 5" (12.7 cm) swivel threaded casters w/ brake & bumper	200 lbs (91 kg)	16
FTCAST5C	Individual 5" (12.7 cm) swivel treaded casters & bumper	200 lbs (91 kg)	16



### 3" or 5" Expandable Stem Casters w/Brakes

## Expandable Threaded Casters

- Heavy-duty grease-resistant, polyurethane non-marking wheels with brakes
- Convert stainless steel worktable into a mobile solution. Rubber stems expand inside worktable legs when tightened for a snug fit.
- 300 lb (136 kg) capacity per wheel.

Item #	Description	Capacity per Caster	Case
FECST3	Set of 4 - 3" (7.6 cm) Expanding Threaded Stem Casters w/Brakes	300 lbs (136 kg)	4
FECST3B	Individual 3" (7.6 cm) Expanding Threaded Stem Casters w/Brakes	300 lbs (136 kg)	4
FECST5	Set of 4 - 5" (12.7 cm) Expanding Threaded Stem Casters w/Brakes	300 lbs (136 kg)	4
FECST5B	Individual 5" (12.7 cm) Expanding Threaded Stem Casters w/Brakes	300 lbs (136 kg)	4

FECST3



FECST5



# Stem Casters and Bumpers

**\*Helpful Hint:** When ordering these type of stem casters specify mobile posts without feet (ie. FGN033C). If you do not specify mobile posts with corresponding item number, you may receive standard stationary posts with footed inserts. Inserts would need to be removed for posts to accommodate these casters.



## Stem Casters

### 5" Thermoplastic Rubber (TPR) Stem Casters

- 2 each swivel and 2 each swivel with brakes and bumpers
- Adds 6" (15.2 cm) of total height of equipment
- 300 lbs. (136 kg) per wheel capacity

Item #	Description	Capacity per Caster	Case
FTPRCST5	Set of 4 - 5" (12.7 cm) TPR set casters (2 swivel/2 swivel brake) & bumpers	300 lbs (136 kg)	4
FTPRCST5B	Individual 5" (12.7 cm) TPR swivel casters w/ brake & bumper	300 lbs (136 kg)	4
FTPRCST5C	Individual 5" (12.7 cm) TPR swivel casters & bumper	300 lbs (136 kg)	4

### 5" Heavy-Duty Polyurethane Stem Casters

- 2 each swivel and 2 each swivel with brakes and bumpers
- Adds 6" (15.2 cm) of total height of equipment
- 300 lbs. (136 kg) per wheel capacity

Item #	Description	Capacity per Caster	Case
FSCAST5	Set of 4 - 5" (12.7 cm) threaded stem casters (2 swivel/2 swivel brake) & bumpers	300 lbs (136 kg)	4
FSCAST5B	Individual 5" (12.7 cm) swivel casters w/ brake & bumper	300 lbs (136 kg)	4
FSCAST5C	Individual 5" (12.7 cm) swivel casters & bumper	300 lbs (136 kg)	4

### 4" Heavy-Duty Polyurethane Stem Casters

- 2 each swivel and 2 each swivel with brakes and bumpers
- Adds 6" (15.2 cm) of total height of equipment
- 300 lbs. (136 kg) per wheel capacity

Item #	Description	Capacity per Caster	Case
FSCAST4	Set of 4 - 4" (10.2 cm) set casters (2 swivel/2 swivel brake) & bumpers	300 lbs (136 kg)	4
FSCAST4B	Individual 4" (10.2 cm) swivel casters w/ brake & bumper	300 lbs (136 kg)	4



## Rigid Casters

### 5" Heavy-Duty Rigid Polyurethane Casters

- 4 casters with bumpers
- Adds approximately 6" (15.2 cm) of total height of equipment
- 300 lbs. (136 kg) per wheel capacity
- Rigid caster must be held in place by channel (sold separately - see below)

Item #	Description	Capacity per Caster	Case
FSCAST5RG	Set of 4 - 5" (12.7 cm) TPR set casters (2 swivel/2 swivel brake) & bumpers	300 lbs (136 kg)	4

### Single Caster Channels for Rigid Casters - [Sold as singles for mobile carts]

Item #	Description	Case
FCC18SS	Fits 18: (45.7 cm) wide shelves	1
FCC21SS	Fits 21: (53.0 cm) wide shelves	1
FCC24SS	Fits 24: (61.0 cm) wide shelves	1

### 6" Heavy-Duty Rigid Polyurethane Casters

- 4 casters
- Adds approximately 7" (17.8 cm) of total height of equipment
- 400 lbs. (182 kg) per wheel capacity
- Rigid caster must be held in place by channel (sold separately) see page 34 for sets or order (2) of single channels listed above.

Item #	Description	Capacity per Caster	Case
FTSC6	Set of 4 - 6" (15.2 cm) TPR set casters	400 lbs (182 kg)	80

FSCAST5RG



FTSC6



## Caster Bumpers

### 5" Revolving Donut Bumpers

- 5" (12.7 cm) diameter non-marking rubber bumpers fit snugly over posts
- Minimize damage to walls and furniture

Item #	Description	Case
FBUMP5	Set of 4 - 5" (12.7 cm) PVC revolving donut bumpers	1



# Plate Casters for Commercial Equipment



**CROWN BRANDS**  
STORAGE AND  
TRANSPORTATION

## Plate Casters

*These casters' stainless steel mounting plates feature multiple bolt holes to fit an assortment of equipment.*

### 5" Heavy-Duty Universal Square Plate Casters w/Brakes

- Grease-resistant, non-marking, polyurethane wheels with brakes
- Stainless steel mounting plate with multiple bolt holes to fit an assortment of equipment
- 500 lb (227 kg) capacity per wheel for heavy-duty applications
- Temp. range: 14°F to 212°F (-10°C to 100°C)

Item #	Description	Capacity per Caster	Case
FPCST5HD	Set of 4 - 5" (12.7 cm) Universal Casters, 4" (10.2 cm) Square Plate w/Brakes	500 lbs (226 kg)	4
FPCST5HD	Individual 5" (12.7 cm) Universal Casters, 4" (10.2 cm) Square Plate w/Brakes	500 lbs (226 kg)	4



FPCST5HD

### 2" Universal Low-Profile Plate Casters w/Brakes

- 2" (5.1 cm) wheels with brakes
- Adds 3" (7.6 cm) to overall height
- Stainless steel mounting plate with multiple bolt holes to fit an assortment of equipment
- 200 lb. (91 kg) capacity per wheel
- Temp. range: 14°F to 212°F (-10°C to 100°C)

Item #	Description	Capacity per Caster	Case
FPCS352	Set of 4 - 2" (5.1 cm) Universal Plate Casters w/Brakes 3 1/2" (8.9 x 8.9 cm) Square Plate	250 lbs (113 kg)	4



FPCS352

### 3" or 5" Square Plate Casters w/Brakes

- Grease-resistant, non-marking, polyurethane wheels with brakes
- Stainless steel mounting plate with multiple bolt holes to fit an assortment of equipment
- Temp. range: 14°F to 212°F (-10°C to 100°C)

Item #	Description	Capacity per Caster	Case
FPCST3	Set of 4 - 3" (7.6 cm) Universal Casters, 4" (10.2 cm) Square Plate w/Brakes	250 lbs (113 kg)	4
FPCST5	Set of 4 - 5" (12.7 cm) Universal Casters, 4" (10.2 cm) Square Plate w/Brakes	250 lbs (113 kg)	4

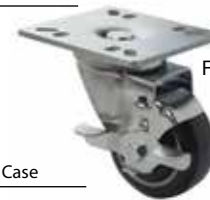

FPCST3



FPCST5

### 5" Universal Square Plate Casters

- Grease-resistant, non-marking, polyurethane wheels with brakes
- Stainless steel mounting plate with multiple bolt holes to fit an assortment of equipment
- Temp. range: 14°F to 212°F (-10°C to 100°C)

Item #	Description	Capacity per Caster	Case
FPCST355	Set of 4 - 5" (12.7 cm) Universal Casters w/Brakes 3 1/2" (8.9 cm) Square Plate	250 lbs (113 kg)	4



### 5" Universal Rectangular Plate Casters w/Brakes

- Grease-resistant, non-marking, polyurethane wheels with brakes
- 250 lb. (113 kg) capacity per wheel
- Temp. range: 14°F to 212°F (-10°C to 100°C)

Item #	Description	Capacity per Caster	Case
FPCST2X35	Set of 4 - 5" (12.7 cm) Universal Casters w/Brakes 2 3/8" x 3 5/8" (6.0 x 9.2 cm) Rectangle Plate	50 lbs (113 kg)	4



### 3" Universal Rectangular Plate Casters\*

- Polyolefin wheel casters, 2 each swivel and 2 each swivel with brakes
- 250 lb. (113 kg) capacity per wheel
- Temp. range: -20°F to +180°F (-28.9°C to +82.2°C)

\*Fits Entree®  
Economy Fryers

Item #	Description	Capacity per Caster	Case
FPCST2X33	Set of 4 - 3" (7.6 cm) Universal Casters w/Brakes 2 3/8" x 3 5/8" (6.0 x 9.2 cm) Rectangle Plate	250 lbs (113 kg)	4



# Plate and Adjustable Height Casters



## 3" Universal Triangular Plate Casters\*

- Grease-resistant, non-marking, polyurethane wheel casters with brakes
- Adds 4 1/16" (10.3 cm) of total height
- 500 lb. (226 kg) per wheel capacity
- Temp. range: 14°F to 212°F (-10°C to 100°C)

\*Fits Garland® Combi Ovens



Item #	Description	Capacity per Caster	Case
FPCTR3	Set of 4 - 3" (7.6 cm) Universal Casters w/Brakes, 5 1/2" x 5 1/2" x 5" (14.0 x 14.0 x 12.7 cm) Triangular Plate	500 lbs (226 kg)	4

## 5" Heavy-Duty Universal Triangular Plate Casters\*

- Grease-resistant, non-marking, polyurethane wheels, 2 swivel and 2 swivel with brakes
- 500 lb. (226 kg) per wheel capacity
- Temp. range: 14°F to 212°F (-10°C to 100°C)

\*Fits Blodgett® Convection Ovens



Item #	Description	Capacity per Caster	Case
FPCTR5	Set of 4 - 5" (12.7 cm) Heavy-Duty Casters 5 3/8" x 5 3/8" x 7 1/2" (13.7 x 13.7 x 19.1 cm) Triangular Plate	500 lbs (226 kg)	4

## 3" Adjustable Height Casters\*

- Grease-resistant, non-marking, polyurethane wheels
- 2 each swivel and 2 each swivel with brakes
- Adds 7" (17.8 cm) of total height of equipment
- 220 lbs. (99.8 kg) capacity per caster

### Adjustable Height Casters

\*Fits Vulcan® Fryers



Item #	Description	Capacity per Caster	Case
FAC31	Set of 4 each 3" (7.6 cm) Adjustable Height Casters	220 lbs (99 kg)	4

## 3" Adjustable Height 3 1/4" Square Plate Fryer Casters\*

- Grease-resistant, non-marking, polyurethane wheels
- 2 each swivel and 2 each swivel with brakes
- Adds 6" (15.2 cm) of total height of equipment
- 3 1/4" (8.26 cm) square plate
- 250 lbs. (113 kg) capacity per caster
- Temp. range: 14°F to 212°F (-10°C to 100°C)

\*Fits Pitco® Economy Fryers



Item #	Description	Capacity per Caster	Case
FPCF3253	Set of 4 each 3" (7.6 cm) Adjustable Height Casters 3 1/4" (8.26 cm) Square Plate	250 lbs (113 kg)	4

## 3" Adjustable Height 3 1/4" Square Plate Fryer Casters w/Brakes\*

- Grease-resistant, non-marking, polyurethane wheels
- 2 each swivel and 2 each swivel with brakes
- Adds 9 1/2" (24.1 cm) of total height of equipment
- 3 1/2" (8.9 cm) square plate
- 200 lbs. (91 kg) capacity per caster
- Temp. range: 14°F to 212°F (-10°C to 100°C)

\*Fits Pitco® Fryers



Item #	Description	Capacity per Caster	Case
FPCF353	Set of 4 each 3" (7.6 cm) Adjustable Height Casters 3 1/2" (8.89 cm) Square Plate	220 lbs (99 kg)	4

## 4" Adjustable Height 3 1/2" Square Plate Fryer Casters w/Brakes\*

- 4" (10.2 cm) adjustable height casters
- Add 8" (20.3 cm) of total height of equipment
- 220 lbs. (113 kg) capacity per caster

\*Fits Vulcan® Fryers



Item #	Description	Capacity per Caster	Case
FAC4125	Set of 4 - 4" (10.2 cm) Adjustable Height Casters 3 1/2" (8.9 cm) Square Plate	220 lbs (113 kg)	4

\* This product is not manufactured or authorized by any other manufacturer. Registered Trade Name or Mark of the original manufacturer of the product which this caster fits is not owned, associated or to be confused with our company.

# Now, You've Got Even More Options!



**CROWN BRANDS**  
STORAGE AND  
TRANSPORTATION

Besides the comprehensive assortment of shelving styles and finishes, we offer a variety of components, kits and systems for whatever your needs may be. Here are just a few examples. Many of these items are available in **green epoxy**, too!



**NSF**

### Need strength, flexibility & versatility?

Choose from our comprehensive assortment of stainless steel, FPS-PLUS™, green epoxy, black epoxy or chromate shelving and accessories.



**NSF**

### Need to fill every corner?

Our corner shelves do the trick. Available in 3 sizes. Chromate for dry storage or green epoxy for wet or cold applications.



**NSF**

### Need to get more stability?

Add an aluminum truck dolly to get you there safe and sound. Available in 3 standard sizes.



**NSF**

### Need to protect valuables?

Security cages minimize loss and inventory shrinkage. The cage's heavy duty, open wire panel construction allows you to keep an eye on the contents.



**NSF**

### Need more durable working spaces?

Stainless steel worktables and equipment stands are ready for any challenge. Rolled and welded sides for strength and safety and rivited hat channels for extra support.



**NSF**

### Need to utilize empty wall space?

Along with our EZ-WALL System, we carry direct wall mount and post-type mounts as well as k/d shelf kits that will really help get you off the ground.



JOHNSON-ROSE

## VALUE ADDED



For over 70 years,  
Johnson-Rose  
has built a  
legacy of quality  
and service with  
their customers

in Canada, United States and  
globally. Crown Brands  
recognizes the value of the  
brand and its product line.  
The Johnson-Rose smallwares  
selection provides more  
economical extensions to  
our other brands' assortments.  
Plus, items like ware washing

baskets help  
broaden our  
offering even  
more.



**JOHNSON-ROSE**  
Call: 800.968.3918  
Fax: 800.968.4129  
Click: [orders@crown-brands.com](mailto:orders@crown-brands.com)  
Search: [www.crown-brands.com](http://www.crown-brands.com)

Steam Table Pans



Ware Washing Racks



# Green Epoxy Shelving & Posts



**CROWN BRANDS**  
STORAGE AND  
TRANSPORTATION



NSF APPROVED: These commercial rated green epoxy coated shelves, posts are ideal for any storage application, dry or wet.



LIMITED WARRANTY: We offer a 5-year warranty covers our green epoxy shelves and posts against rust or corrosion or manufacturer's defect when used under general conditions.

## Green Epoxy Coated Shelves

Item #	Shelf Size (width x length)		Case
	(in.)	(cm)	
21424	14" X 24"	35.5 X 61.0	4
21430	14" X 30"	35.5 X 76.0	4
21436	14" X 36"	35.5 X 91.4	4
21442	14" X 42"	35.5 X 106.6	4
21448	14" X 48"	35.5 X 122.0	4
21454	14" X 54"	35.5 X 137.0	2
21460	14" X 60"	35.5 X 152.4	2
21472	14" X 72"	35.5 X 182.9	2
21824	18" X 24"	45.7 X 61.0	4
21830	18" X 30"	45.7 X 76.0	4
21836	18" X 36"	45.7 X 91.4	4
21842	18" X 42"	45.7 X 106.6	4
21848	18" X 48"	45.7 X 122.0	4
21854	18" X 54"	45.7 X 137.0	2
21860	18" X 60"	45.7 X 152.4	2
21872	18" X 72"	45.7 X 182.9	2
22124	21" X 24"	53.0 X 60.1	4
22130	21" X 30"	53.0 X 76.0	4
22136	21" X 36"	53.0 X 91.4	4
22142	21" X 42"	53.0 X 106.6	4
22148	21" X 48"	53.0 X 122.0	4
22154	21" X 54"	53.0 X 137.0	2
22160	21" X 60"	53.0 X 152.4	2
22172	21" X 72"	53.0 X 182.9	2
22424	24" X 24"	60.1 X 60.1	4
22430	24" X 30"	60.1 X 76.0	4
22436	24" X 36"	60.1 X 91.4	4
22442	24" X 42"	60.1 X 106.6	4
22448	24" X 48"	60.1 X 122.0	4
22454	24" X 54"	60.1 X 137.0	2
22460	24" X 60"	60.1 X 152.4	2
22472	24" X 72"	60.1 X 182.9	2



Shelves up to 48" are rated to hold up to 800 lbs.

## Green Epoxy Coated Posts

Item #	(in.)	(cm)	Case
21008	8"	20.3	4
21013	13"	33.0	4
21034	34"	86.4	4
21054	54"	137.0	4
21064	64"	162.6	4
21064CA*	64"	162.6	4
21072	72"	182.9	4
21072CA*	72"	182.9	4
21084	84"	213.4	4
21084CA*	84"	213.4	4
21172	72" (2-piece posts)	182.9	2



Posts are grooved and marked every inch for easy installation.  
21064CA\*, 21072CA\* and 21084CA\* = Posts for caster applications

# Chrome Shelving & Posts



**NSF APPROVED:** These commercial rated chrome shelves, posts are recommended for dry storage applications only.



**LIMITED WARRANTY:** We offer a 1-year warranty covers our chrome finish shelves and posts against rust or corrosion or manufacturer's defect when used under general conditions.

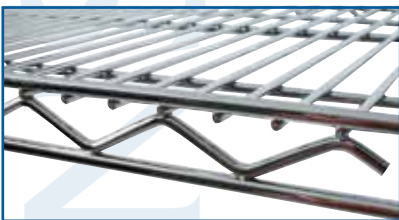

*Shelves up to 48" are rated to hold up to 800 lbs.*



*Posts are grooved and marked every inch for easy installation. 21064CA\*, 21072CA\* and 21084CA\* = Posts for caster applications 21172\*\* = Set of 2 posts. Grooved every inch with no markings*

## Chrome Finish Shelves

Item #	Shelf Size (width x length)		Case
	(in.)	(cm)	
11424	14" X 24"	35.5 X 61.0	4
11430	14" X 30"	35.5 X 76.0	4
11436	14" X 36"	35.5 X 91.4	4
11442	14" X 42"	35.5 X 106.6	4
11448	14" X 48"	35.5 X 122.0	4
11454	14" X 54"	35.5 X 137.0	2
11460	14" X 60"	35.5 X 152.4	2
11472	14" X 72"	35.5 X 182.9	2
11818	18" X 18"	45.7 X 45.7	4
11824	18" X 24"	45.7 X 61.0	4
11830	18" X 30"	45.7 X 76.0	4
11836	18" X 36"	45.7 X 91.4	4
11842	18" X 42"	45.7 X 106.6	4
11848	18" X 48"	45.7 X 122.0	4
11854	18" X 54"	45.7 X 137.0	2
11860	18" X 60"	45.7 X 152.4	2
11872	18" X 72"	45.7 X 182.9	2
12124	21" X 24"	53.0 X 60.1	4
12130	21" X 30"	53.0 X 76.0	4
12136	21" X 36"	53.0 X 91.4	4
12142	21" X 42"	53.0 X 106.6	4
12148	21" X 48"	53.0 X 122.0	4
12154	21" X 54"	53.0 X 137.0	2
12160	21" X 60"	53.0 X 152.4	2
12172	21" X 72"	53.0 X 182.9	2
12424	24" X 24"	60.1 X 60.1	4
12430	24" X 30"	60.1 X 76.0	4
12436	24" X 36"	60.1 X 91.4	4
12442	24" X 42"	60.1 X 106.6	4
12448	24" X 48"	60.1 X 122.0	4
12454	24" X 54"	60.1 X 137.0	2
12460	24" X 60"	60.1 X 152.4	2
12472	24" X 72"	60.1 X 182.9	2

## Chrome Finish Posts

Item #	(in.)	(cm)	Case
11013	13"	33.0	4
11034	34"	86.4	4
11054	54"	137.2	4
11064	64"	162.6	4
11072	72"	182.9	4
11072CA*	72"	182.9	4
11084	84"	213.4	4
11172**	72"	182.9	2
11173	72" (3-piece set)	182.9	2



# Shelving Kits, Security Cages and Carts



**CROWN BRANDS**  
STORAGE AND TRANSPORTATION



Kits include: (4) Shelves, (4) Posts and (32) Split Sleeves

## Chrome or Green Epoxy Shelf Kits

Chrome Finish Item #	Green Epoxy Item#	Shelf Size (width x length)		Case
		(in.)	(cm)	
118367	218367	18" x 36" x 72"	45.7 x 91.4 x 182.9	1
118368	218368	18" x 36" x 84"	45.7 x 91.4 x 213.4	1
118487	218487	18" x 48" x 72"	45.7 x 122.0 x 189.2	1
118488	218488	18" x 48" x 84"	45.7 x 122.0 x 213.4	1
118607	218607	18" x 60" x 72"	45.7 x 152.4 x 189.2	1
118608	218608	18" x 60" x 84"	45.7 x 152.4 x 213.4	1
124367	224367	24" x 36" x 72"	60.1 x 91.4 x 182.9	1
124368	224368	24" x 36" x 84"	60.1 x 91.4 x 213.4	1
124487	224487	24" x 48" x 72"	60.1 x 122.0 x 182.9	1
124488	224488	24" x 48" x 84"	60.1 x 122.0 x 213.4	1
124607	224607	24" x 60" x 72"	60.1 x 152.4 x 182.9	1
124608	224608	24" x 60" x 84"	60.1 x 152.4 x 213.4	1

## Shelving Kits

## Heavy-Duty Chrome or Green Epoxy Shelf Kits

**A Great Cash and Carry Opportunity:** Provide a complete shelving unit in one box.



Kits include: (4) Shelves with slip sleeves and (4) 72" stationary posts with levelers. Shipped in a white corrugated box with a full color label

Chrome Finish Item #	Green Epoxy Item#	Shelf Size (width x length)		Case
		(in.)	(cm)	
11402		14" x 48" x 72"	35.5 x 122.0 x 182.9	1
	21502	18" x 48" x 72"	45.7 x 122.0 x 189.2	1

UPDATED ITEM#S

## Chrome or Green Epoxy Security Cages



Chrome Finish Item #	Green Epoxy Item#	Shelf Size (width x length)		Case(s)*
		(in.)	(cm)	
10003C	20003G	24" x 36" x 68"	60.1 x 91.4 x 172.7	1*
10004C	20004G	24" x 48" x 68"	60.1 x 122.0 x 172.7	1*
10006C	20006G	24" x 60" x 68"	60.1 x 152.4 x 172.7	1*
10007C	20007G	24" x 72" x 68"	60.1 x 182.9 x 172.7	1*

\*Ships in 3 cases: (2) side panels, (2) back panels, (2) Lockable Front doors, (4) Shelves, (4) 63" Split Posts, (32) Split Sleeves and (4) Swivel Casters (2 w/brakes)



## Heavy-Duty 2-Shelf Chrome Wire Carts

Each cart includes: (2) heavy-duty chrome wire shelves, (4) 5" locking "resilient" polyurethane casters and (2) handles.

Item #	Description	Shelf Size (width x length)		Case
		(in.)	(cm)	
31824	Chromate Wire Cart	18" x 24"	45.7 x 60.1	1
31836	Chromate Wire Cart	18" x 36"	45.7 x 91.4	1
32436	Chromate Wire Cart	24" x 36"	60.1 x 91.4	1



# Keeping it Neat and Clean.

## RACKS & SINKS

### Dunnage Racks

Item #	Description	Case
82414	14" x 24" x 8" (35.5 x 60.1 x 20.3 cm) Dunnage Rack	6
83614	14" x 36" x 8" (35.5 x 91.4 x 20.3 cm) Dunnage Rack	6
84814	14" x 48" x 8" (35.5 x 121.9 x 20.3 cm) Dunnage Rack	6
83622	20" x 36" x 12" (50.8 x 91.4 x 30.4 cm) Dunnage Rack	6
83628	20" x 36" x 8" (50.8 x 91.4 x 20.3 cm) Dunnage Rack	6
84822	20" x 48" x 12" (50.8 x 121.9 x 30.4 cm) Dunnage Rack	6
84828	20" x 48" x 8" (50.8 x 121.9 x 20.3 cm) Dunnage Rack	6
86028	20" x 60" x 8" (50.8 x 152.4 x 20.3 cm) Dunnage Rack	6



84822

### Space Savers

#### K/D Bun Pan Racks & Covers

1.5 mm Gauge aluminum racks are shipped knocked down. 3" Spacing between pan glides.

10310



10350



10351



10311



Item #	Description	Case
10310	Bun Pan Rack, Holds 10 Full Size Pans (20 Half Size Pans)	1
10350	Bun Pan Rack, Holds 20 Full Size Pans (40 Half Size Pans)	1
10311	Bun Pan Rack Cover for 10 Tier Pan Rack	12
10351	Bun Pan Rack Cover for 10 Tier Pan Rack	12

### Hand Sinks

304 Stainless Steel Hand Sinks with Fabricated Bowls. All sinks include lead free faucet and drain.

81401



81500



81520

Item #	Description	Case
81500	17" x 15 3/8" x 14 1/2" Hand Sink with 14" x 10" x 5 1/4" Bowl includes (lead free) faucet and drain	1
81501	17" x 15 3/8" x 14 1/2" Hand Sink with Side Splashes 14" x 10" x 5 1/4" Bowl - includes (lead free) faucet and drain	1
81400	16" x 12" x 13" Hand Sink with 00" x 00" x 00" Bowl includes (lead free) faucet and drain	1
81401	16" x 12" x 13" Hand Sink with Side Splashes 00" x 00" x 00" Bowl - includes (lead free) faucet and drain	1
81520	Hand Sink Wrist Blade Handles	1



# Wall Shelving Options



**CROWN BRANDS**  
STORAGE AND  
TRANSPORTATION

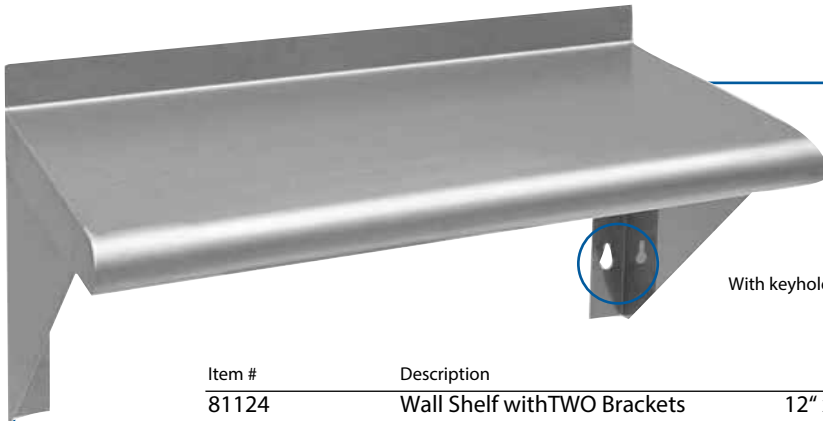

## Wall Shelves:

**430 Stainless Steel**  
**1 1/2" Up-Turn Back**  
Provided with TWO or  
THREE 8 1/2" angled  
brackets.



With keyholes for easier installation

Item #	Description	Shelf dimensions		Case
		(in.)	(cm)	
81124	Wall Shelf withTWO Brackets	12" x 24" x 10"	30.5 x 61.0 x 25.4	1
81136	Wall Shelf withTWO Brackets	12" x 36" x 10"	30.5 x 91.4 x 25.4	1
81148	Wall Shelf withTWO Brackets	12" x 48" x 10"	30.5 x 122.0 x 25.4	1
81160	Wall Shelf withTWO Brackets	12" x 60" x 10"	30.5 x 152.4 x 25.4	1
81172	Wall Shelf withTHREE Brackets	12" x 72" x 10"	30.5 x 182.9 x 25.4	1
81184	Wall Shelf withTHREE Brackets	12" x 84" x 10"	30.5 x 213.4 x 25.4	1
81196	Wall Shelf withTHREE Brackets	12" x 96" x 10"	30.5 x 243.8 x 25.4	1
81624	Wall Shelf withTWO Brackets	16" x 24" x 10"	40.6 x 61.0 x 25.4	1
81636	Wall Shelf withTWO Brackets	16" x 36" x 10"	40.6 x 91.4 x 25.4	1
81648	Wall Shelf withTWO Brackets	16" x 48" x 10"	40.6 x 122.0 x 25.4	1
81660	Wall Shelf withTWO Brackets	16" x 60" x 10"	40.6 x 152.4 x 25.4	1
81672	Wall Shelf withTHREE Brackets	16" x 72" x 10"	40.6 x 182.9 x 25.4	1
81684	Wall Shelf withTHREE Brackets	16" x 84" x 10"	40.6 x 213.4 x 25.4	1
81696	Wall Shelf withTHREE Brackets	16" x 96" x 10"	40.6 x 243.8 x 25.4	1

## Microwave Shelves



With keyholes for easier installation

Item #	Description	Case
81824	Microwave Shelf 18" x 24" (47.5 x 61.0 cm)	1
81424	Microwave Shelf 24" x 24" (61.0 x 61.0 cm)	1

## Wall Brackets for Shelves

Chrome Finish Item #	Green Epoxy Item#	Description	Case
11003		18" (47.5 cm) Wall Bracket	10
11114	21114	14" (35.5 cm) Wall Bracket	20
11118	21118	18" (47.5 cm) Wall Bracket	20
11121	21121	21" (35.5 cm) Wall Bracket	20
11124	21124	24" (60.1 cm) Wall Bracket	20
11115	21115	14" (35.5 cm) Double Wall Bracket	6
11119	21119	18" (35.5 cm) Double Wall Bracket	10
11125	21125	24" (35.5 cm) Double Wall Bracket	10

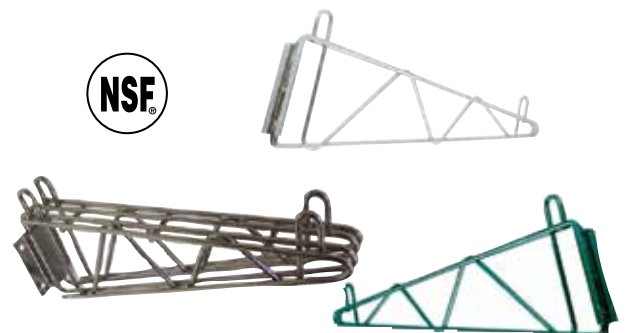

# Shelving Unit Accessories

## [For Posts or Shelves]

Accessories

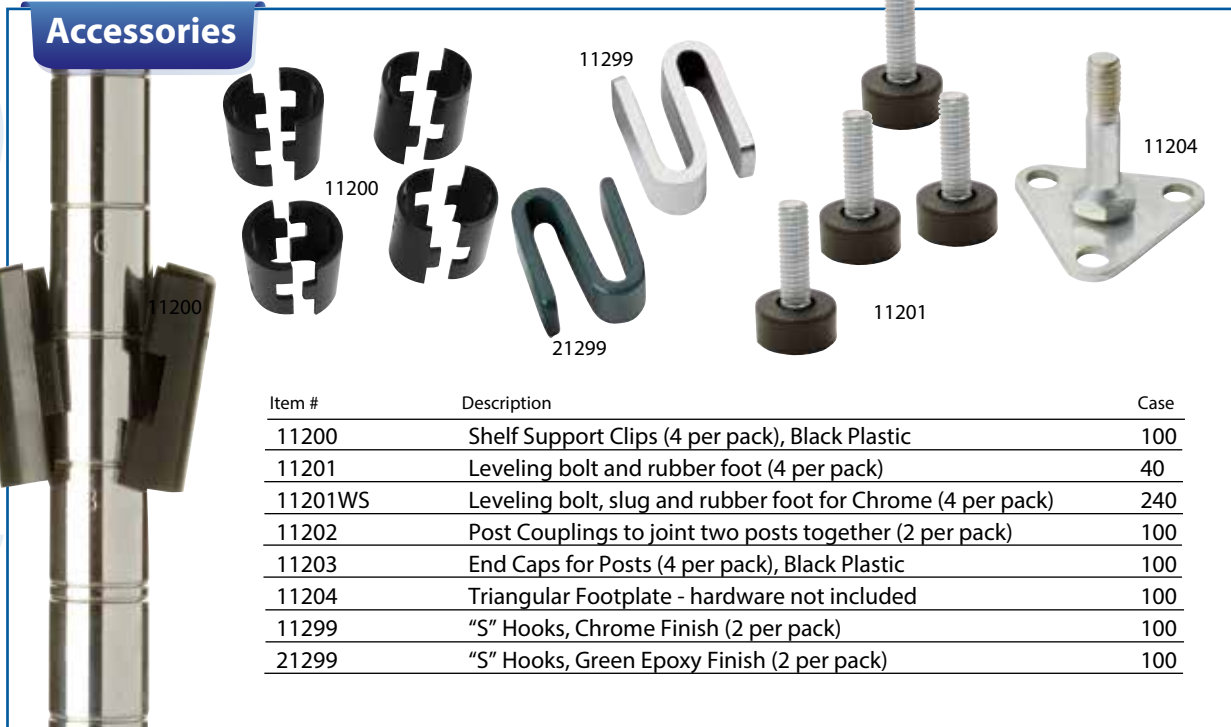

Item #	Description	Case
11200	Shelf Support Clips (4 per pack), Black Plastic	100
11201	Leveling bolt and rubber foot (4 per pack)	40
11201WS	Leveling bolt, slug and rubber foot for Chrome (4 per pack)	240
11202	Post Couplings to joint two posts together (2 per pack)	100
11203	End Caps for Posts (4 per pack), Black Plastic	100
11204	Triangular Footplate - hardware not included	100
11299	"S" Hooks, Chrome Finish (2 per pack)	100
21299	"S" Hooks, Green Epoxy Finish (2 per pack)	100

### Casters for Shelving, Worktables and Equipment

#### SHELVING CASTERS

Item #	Description	Case
11225	Individual 5" Stem "Pop In" Casters for 1.25" Posts. No Brakes	16
11235	Individual 5" Stem "Pop In" Casters for 1.25" Posts. With Brakes	16
11245	Set of 4 - 5" Stem "Pop In" Casters for 1.25" Posts. (2) With Brakes and (2) Without Brakes	4



#### WORKTABLE CASTERS

Item #	Description	Case
81205	Set of 4 - 5" Stem "Pop In" Casters for Worktables. No Brakes	4
81215	Set of 4 - 5" Stem "Pop In" Casters for Worktables. With Brakes	4
81235	Set of 4 - 5" Stem "Pop In" Casters for 1.25" Posts. (2) With Brakes and (2) Without Brakes	4



#### UNIVERSAL EQUIPMENT CASTERS WITH 2 3/8 x 3 5/8 PLATE

Item #	Description	Case
84023	Set of 4 - Plate Casters. 5" Wheels w/brakes. 220 Lb capacity	2



#### UNIVERSAL EQUIPMENT CASTERS WITH 4" x 4" PLATE

Item #	Description	Case
84045	Set of 4 - 5" Wheels w/o brakes. 220 Lb capacity Hole Centers 2 7/8" (outer) 1 3/4" (inner)	2





JOHNSON-ROSE  
OPERATIONAL: 68-70

## SELECTED.

As part of the Crown Brands' initiative to create a good, better, best tiered product structure, we have begun the selection process for our **Crown Select** sub-brand. These items will be chosen based on variety of criteria; quality of materials, innovation, benefits to the operator, etc. The first storage and transportation items from Johnson-Rose to be selected into this group are featured on the following pages. These products are designed and constructed to enhance the user's culinary prep experience service after service, year after year.



# Our best tools for your best work.™



**JOHNSON-ROSE**  
Call: 800.968.3918  
Fax: 800.968.4129  
Click: [orders@crown-brands.com](mailto:orders@crown-brands.com)  
Search: [www.crown-brands.com](http://www.crown-brands.com)

JOHNSON-ROSE  
CROWN  SELECT

# Not Just Worktables...



NSF APPROVED: These commercial rated worktables are ideal for any application, dry or wet.



LIMITED WARRANTY: We offer a 1-year warranty covers our stainless steel worktables against rust or corrosion or manufacturer's defect when used under general conditions.

300 Series

All Stainless Steel Worktables



- Rolled and welded edges
- Welded collars for legs with set screws
- Adjustable bullet feet

81397  
30" x 96" Worktable  
with Backsplash

All tables over 48" feature an additional hat channel.  
(See hat channels on opposite page).  
All Tables 84" or longer include two additional legs in  
the center to increase strength and rigidity.



Our best tools  
for your best work.™

## 300 Series 18 Gauge Stainless Steel Worktables, Stainless Legs and Undershef. 1 1/2" Backsplash (optional).

Worktable Item #	Worktable w/ Backsplash Item#	Description	Table dimensions		Case
			(in.)	(cm)	
82427	81228	Undershef and TWO Hat Channels	24" x 24" x 37"	61.0 x 61.0 x 94	1
82433	81233	Undershef and TWO Hat Channels	24" x 30" x 37"	61.0 x 76.0 x 94	1
82439	81239	Undershef and TWO Hat Channels	24" x 36" x 37"	61.0 x 91.4 x 94	1
82451	81251	Undershef and THREE Hat Channels	24" x 48" x 37"	61.0 x 122.0 x 94	1
82463	81263	Undershef and THREE Hat Channels	24" x 60" x 37"	61.0 x 152.4 x 94	1
82475	81275	Undershef and THREE Hat Channels	24" x 72" x 37"	61.0 x 182.9 x 94	1
82487	81287	Undershef and THREE Hat Channels	24" x 84" x 37"	61.0 x 213.4 x 94	1
82499	81299	Undershef and THREE Hat Channels	24" x 96" x 37"	61.0 x 243.8 x 94	1
83021	81328	Undershef and TWO Hat Channels	30" x 18" x 37"	76.0 x 45.7 x 94	1
83033	81331	Undershef and TWO Hat Channels	30" x 30" x 37"	76.0 x 76.0 x 94	1
83039	81337	Undershef and TWO Hat Channels	30" x 36" x 37"	76.0 x 91.4 x 94	1
83052	81349	Undershef and THREE Hat Channels	30" x 48" x 37"	76.0 x 122.0 x 94	1
83063	81361	Undershef and THREE Hat Channels	30" x 60" x 37"	76.0 x 152.4 x 94	1
83075	81373	Undershef and THREE Hat Channels	30" x 72" x 37"	76.0 x 189.2 x 94	1
83087	81385	Undershef and THREE Hat Channels	30" x 84" x 37"	76.0 x 213.4 x 94	1
83099	81397	Undershef and THREE Hat Channels	30" x 96" x 37"	76.0 x 243.8 x 94	1

# Worktables That Really Work.



**CROWN BRANDS**  
STORAGE AND  
TRANSPORTATION

## 430 Series

### Stainless Steel Top Worktables with Galvanized legs and Undershelf

#### All 430 Series Worktables feature:

- Fully hemmed on all sides, no sharp edges.
- Two set screws top and bottom of each leg, keeping legs securely positioned, yet adjustable.
- Hat channel is welded on each end, permanently riveted every 12" and sealed on all sides with silicone.
- All tables 48" & longer have an additional hat channel in the center for added strength.

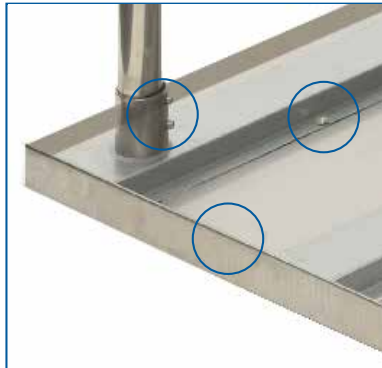

Extra galvanized undershelves sold separately. [see bottom of page]



82430  
24" x 30" Worktable  
with galvanized legs  
and undershelf

## 430 Series 18 Gauge Stainless Steel Worktables with Galvanized Legs and Undershelf. Available with or without a 1 1/2" Backsplash.

Worktable Item #	Worktable w/ Backsplash Item#	Description	Table dimensions		Case
			(in.)	(cm)	
82424	82425	Undershelf and TWO Hat Channels	24" x 24" x 37"	61.0 x 61.0 x 94	1
82430	82431	Undershelf and TWO Hat Channels	24" x 30" x 37"	61.0 x 76.0 x 94	1
82436	82437	Undershelf and TWO Hat Channels	24" x 36" x 37"	61.0 x 91.4 x 94	1
82448	82449	Undershelf and THREE Hat Channels	24" x 48" x 37"	61.0 x 122.0 x 94	1
82460	82461	Undershelf and THREE Hat Channels	24" x 60" x 37"	61.0 x 152.4 x 94	1
82472	82473	Undershelf and THREE Hat Channels	24" x 72" x 37"	61.0 x 182.9 x 94	1
82484		Undershelf and THREE Hat Channels	24" x 84" x 37"	61.0 x 213.4 x 94	1
82496		Undershelf and THREE Hat Channels	24" x 96" x 37"	61.0 x 243.8 x 94	1
83018	83019	Undershelf and TWO Hat Channels	30" x 18" x 37"	76.0 x 45.7 x 94	1
83030	83031	Undershelf and TWO Hat Channels	30" x 30" x 37"	76.0 x 76.0 x 94	1
83036	83037	Undershelf and TWO Hat Channels	30" x 36" x 37"	76.0 x 91.4 x 94	1
83048	83049	Undershelf and THREE Hat Channels	30" x 48" x 37"	76.0 x 122.0 x 94	1
83060	83061	Undershelf and THREE Hat Channels	30" x 60" x 37"	76.0 x 152.4 x 94	1
83072	83073	Undershelf and THREE Hat Channels	30" x 72" x 37"	76.0 x 189.2 x 94	1
83084	83085	Undershelf and THREE Hat Channels	30" x 84" x 37"	76.0 x 213.4 x 94	1
83096	83097	Undershelf and THREE Hat Channels	30" x 96" x 37"	76.0 x 243.8 x 94	1

### Need an extra undershelf? We have those, too.

Item #	Description	Case	Item #	Description	Case
82424GUS	Undershelf, Galvanized, 24" x 24" (61.0 x 61.0)	1	83048GUS	Undershelf, Galvanized, 30" x 48" (76.0 x 122.0)	1
82436GUS	Undershelf, Galvanized, 24" x 36" (61.0 x 91.4)	1	83060GUS	Undershelf, Galvanized, 30" x 60" (76.0 x 152.4)	1
83018GUS	Undershelf, Galvanized, 30" x 18" (76.0 x 45.7)	1	83072GUS	Undershelf, Galvanized, 30" x 72" (76.0 x 189.2)	1
83036GUS	Undershelf, Galvanized, 30" x 36" (76.0 x 91.4)	1	83096GUS	Undershelf, Galvanized, 30" x 96" (76.0 x 243.8)	1

# Well Equipped Shelves & Stands



NSF APPROVED: These commercial rated worktables are ideal for any application, dry or wet.



LIMITED WARRANTY: We offer a 1-year warranty covers our stainless steel worktables against rust or corrosion or manufacturer's defect when used under general conditions.

## Overshelves for Stainless Steel Worktables



- All Single and Double Tier are made of 18 gauge, 430 Stainless Steel.
- They feature Stainless Steel legs and sockets.
- Easily attach to worktables with set screws (Allen Wrench included).
- Screws for permanent anchoring to table also included.



Single Overshelf Item #	Double Shelf Item#	Description	Overshelf dimensions (in.)	(cm)	Case
81225	81226	18 Gauge, 430 Stainless Steel Overshelf	12" x 24"	30.5 x 61.0	1
81231	81232	18 Gauge, 430 Stainless Steel Overshelf	12" x 30"	30.5 x 76.0	1
81237	81238	18 Gauge, 430 Stainless Steel Overshelf	12" x 36"	30.5 x 91.4	1
81249	81250	18 Gauge, 430 Stainless Steel Overshelf	12" x 48"	30.5 x 122.0	1
81261	81262	18 Gauge, 430 Stainless Steel Overshelf	12" x 60"	30.5 x 152.4	1
81273	81274	18 Gauge, 430 Stainless Steel Overshelf	12" x 72"	30.5 x 182.9	1
81285	81286	18 Gauge, 430 Stainless Steel Overshelf	12" x 84"	30.5 x 213.4	1
81297	81298	18 Gauge, 430 Stainless Steel Overshelf	12" x 96"	30.5 x 243.8	1
81825	81826	18 Gauge, 430 Stainless Steel Overshelf	18" x 24"	45.7 x 61.0	1
81831	81832	18 Gauge, 430 Stainless Steel Overshelf	18" x 30"	45.7 x 76.0	1
81837	81838	18 Gauge, 430 Stainless Steel Overshelf	18" x 36"	45.7 x 91.4	1
81849	81850	18 Gauge, 430 Stainless Steel Overshelf	18" x 48"	45.7 x 122.0	1
81861	81862	18 Gauge, 430 Stainless Steel Overshelf	18" x 60"	45.7 x 152.4	1
81873	81874	18 Gauge, 430 Stainless Steel Overshelf	18" x 72"	45.7 x 189.2	1

## Equipment Stands with 18 Gauge Stainless Steel Top, Galvanized Legs and Undershelf

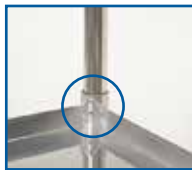

- Same great features as the worktables.
- Front of stand allows for easy loading of heavy equipment.
- Three sides constructed higher for containment.

Item #	Description	(in.)	(cm)	Case
82312	Stainless Steel Equipment Stand	30" x 12"	30.5 x 61.0	1
82315	Stainless Steel Equipment Stand	30" x 15"	30.5 x 76.0	1
82318	Stainless Steel Equipment Stand	30" x 18"	30.5 x 91.4	1
82324	Stainless Steel Equipment Stand	30" x 24"	30.5 x 122.0	1
82330	Stainless Steel Equipment Stand	30" x 30"	30.5 x 152.4	1
82336	Stainless Steel Equipment Stand	30" x 36"	30.5 x 182.9	1
82348	Stainless Steel Equipment Stand	30" x 48"	30.5 x 213.4	1
82360	Stainless Steel Equipment Stand	30" x 60"	30.5 x 243.8	1
82372	Stainless Steel Equipment Stand	30" x 72"	45.7 x 61.0	1





# Easy to Buy...Easier to Build.



**CROWN BRANDS**  
STORAGE AND  
TRANSPORTATION

Standard table height is 25 1/2" / Stand bar height is 38 1/2". Bases always come with leveling guides. Hardware is not provided with any "Spiders". 13" spiders are provided with 18" and 22" round kits; 22" x 22" x-bases, 24" x 30" x-bases; 22" end kits. 15" spiders are provided with all other table bases.

## Tables and Bases Compatibility Chart

Table Size	Round Base	If Bar Height	Cross Base	If Bar Height	"Spider" Mount
24" Round	18"	18"	Up to 22" X 22"	Up to 22" X 22"	8" - 13"
30" Round	18"	22"	22" X 22"	22" X 22"	13"
36" Round	22"	22"	30" X 30"	30" X 30"	15"-18"
42" Round	30"	30"	33" X 33"	33" X 33"	15"-18"
48" Round	30"	30"	33" X 33"	33" X 33"	15"-18"
54" Round	30"	30"	(2) 22" End Kit	(2) 22" End Kit	15"-18"
60" Round	(3) 18"	(3) 18"	(2) 22" End Kit	(2) 22" End Kit	(3) 8"-13"
18" X 24"	18"	18"	22" X 22"	22" X 22"	8" - 13"
24" X 24"	18"	18"	Up to 22" X 22"	22" X 22"	8" - 13"
24" X 30"	22"	22"	Up to 22" X 22"	22" X 22"	15"-18"
24" X 36"	22"	22"	22" X 22" or 30"	24" X 30"	15"-18"
24" X 42"	22"	22"	22" or 24" X 30"	24" X 30"	15"-18"
24" X 48"	22"	(2) 18"	24" X 30"	24" X 30"	(2) 8"-13"
24" X 60"	(2) 18"	(2) 18"	(2) 22" End Kit	(2) 22" End Kit	(2) 15"-18"
30" X 30"	18"	18"	22" X 22"	22" X 22"	15"-18"
30" X 36"	22"	22"	24" X 30"	24" x 30"	15"-18"
30" X 42"	22"	30"	24" X 30"	24" x 30"	15"-18"
30" X 48"	22"	30"	30" X 30"	30" X 30"	15"-18"
30" X 60"	(2) 18"	(2) 22"	(2) 22" End Kit	(2) 22" End Kit	(2) 8" - 13"
30" X 72"	(2) 18"	(2) 22"	(2) 22" End Kit	(2) 22" End Kit	(2) 8" - 13"
30" X 84"	(2) 18"	(2) 22"	(2) 22" End Kit	(2) 22" End Kit	(2) 8" - 13"
30" X 96"	(3) 18"	(2) 22"	(3) 22" End Kit	(3) 22" End Kit	(3) 8" - 13"
36" X 36"	22"	30"	30" X 30"	30" X 30"	15"-18"
36" X 42"	30"	30"	30" X 30"	30" X 30"	15"-18"
36" X 48"	30"	30"	30" X 30"	30" X 30"	15"-18"
36" X 60"	(2) 22"	(2) 22"	(2) 22" End Kit	(2) 22" End Kit	15"-18"
36" X 72"	(2) 22"	(2) 22"	(2) 30" X 30"	(2) 24" X 24"	15"-18"
36" X 84"	(2) 22"	(2) 22"	(3) 22" End Kit	(3) 22" End Kit	15"-18"
36" X 96"	(2) 30"	(2) 30"	(3) 24" X 30"	(3) 30" x 30"	15"-18"



# From Tops to Bottoms...

High-quality standard dining and bar height tables components to fit any front of house application. Designed to enhance; constructed to last.

**Reversible** table tops for banquet, restaurants and bars.

**Table Top Features:**

- Standard table height: 25 1/2"
- Bar height tables: 38 1/2"
- Table tops are constructed of 1" particle board sandwiched between melamine laminates.
- Tops feature different finishes per side. Choose from Oak/ Walnut or Mahogany/ Black.

JOHNSON-ROSE  
 CROWN SELECT



Over 30 sizes / styles to choose from.

Oak/Walnut Item #	Mahogany/Black Item#	Description	Table top dimensions		Case
			(in.)	(cm)	
91111	91211	24" Round Diameter Table Top	24"	61.0	1
91112	91212	30" Round Diameter Table Top	30"	76.0	1
91113	91213	36" Round Diameter Table Top	36"	91.4	1
91116	91216	48" Round Diameter Table Top	48"	122.0	1
91117	91217	60" Round Diameter Table Top	60"	152.4	1
91121	91221	2' x 2' Square Table Top	24" x 24"	61.0 x 61.0	1
91132	91232	2.5' x 2.5' Square Table Top	30" x 30"	76.0 x 76.0	1
91143	91243	3' x 3' Square Table Top	36" x 36"	91.4 x 91.4	1
91122	91222	2' x 2.5' Rectangular Table Top	24" x 30"	61.0 x 76.0	1
	91223	2' x 3' Rectangular Table Top	24" x 36"	61.0 x 91.4	1
91124	91224	2' x 3.5' Rectangular Table Top	24" x 42"	61.0 x 106.6	1
91126		2' x 4' Rectangular Table Top	24" x 48"	61.0 x 122.0	1
	91225	2' x 3.75' Rectangular Table Top	24" x 45"	61.0 x 114.3	1
91134	91234	2.5' x 3.5' Rectangular Table Top	30" x 42"	76.0 x 106.6	1
91135	91235	2.5' x 3.75' Rectangular Table Top	30" x 45"	76.0 x 114.3	1
91136	91236	2.5' x 4' Rectangular Table Top	30" x 48"	76.0 x 122.0	1
	91237	2.5' x 5' Rectangular Table Top	30" x 60"	76.0 x 152.4	1
91138		2.5' x 6' Rectangular Table Top	30" x 72"	76.0 x 189.2	1

# Our Table Tops and Bases Are Ready for Service.



**CROWN BRANDS**  
STORAGE AND  
TRANSPORTATION

**2-piece & 3-piece table base kits to fit our table tops and your needs.**

### Table Base Features:

- Heavy-duty cast iron bases include spider, column, rod and nut, base and leveling guides
- Bases have a black wrinkle finish to help hide scratches and scuffs from everyday usage.

*Complete  
2-Piece  
Round Kit:  
Quick and Easy  
Installation*



**3-Piece  
Round Kit**



**3-Piece  
X-Base Kit**



9614, 9615

9617

96101  
96121

96029-96339

### Table Base Kits

3-Piece Item #	2-Piece Item #	Description	(in.)	Base dimensions (cm)	Case
9018	9818	Round Kit Standard 18" Diameter	18"	45.7	1
90185	98185	Round Kit Bar Height 18" Diameter	18"	45.7	1
9022	9822	Round Kit Standard 22" Diameter	22"	55.8	1
90225	98225	Round Kit Bar Height 22" Diameter	22"	55.8	1
9030	9830	Round Kit Standard 30" Diameter	30"	76.0	1
90305	98305	Round Kit Bar Height 30" Diameter	30"	76.0	1
9601	9801	End Kit Standard 22" Length	22"	55.8	1
96015	98015	End Kit Bar Height 22" Diameter	22"	55.8	1
9602	9802	X-Base Kit Standard 2' x 2.5'	24" x 30"	61.0 x 76.0	1
96025	98025	X-Base Kit Bar Height 2' x 2.5'	24" x 30"	61.0 x 76.0	1
9622	9824	X-Base Kit Standard 22" x 22"	22" x 22"	55.8 x 55.8	1
96225	98245	X-Base Kit Bar Height 22" x 22"	22" x 22"	55.8 x 55.8	1
9630	9834	X-Base Kit Standard 2.5' x 2.5'	30" x 30"	76.0 x 76.0	1
96305	98345	X-Base Kit Bar Height 2.5' x 2.5'	30" x 30"	76.0 x 76.0	1
9633	9833	X-Base Kit Standard 33" x 33"	33" x 33"	83.8 x 83.8	1
96335	98335	X-Base Kit Bar Height 33" x 33"	33" x 33"	83.8 x 83.8	1



### Table Base Components

Item #	Description	Case	Item #	Description	Case
96100	Standard Height Column/Spider Only	8	90189	Table Base Only, 18" (45.7 cm) Diameter	5
96120	Bar Height Column/Spider Only	8	90229	Table Base Only, 22" (55.8 cm) Diameter	2
9615	Cast Iron Spider, 13" (33cm) Diameter	10	96309	Casing Only, 30" x 30" (76.0 x 76.0 cm)	1
9614	Cast Iron Spider, 15" (38.1cm) Diameter	10	96019	End Casing Only, 22" (55.8 cm) Length	10
96101	Column, 26 3/4" (67.9 cm) Steel Rod/Nut, 25" (63.5cm)L	10	96229	Casing Only, 22" x 22" (55.8 x 55.8 cm)	5
96121	Column, 40 1/8" (102 cm) Steel Rod/Nut, 38" (96.5cm)L	10	96029	Casing Only, 24" x 30" (61.0 x 76.0 cm)	5
9610	Column Only, 25" (63.5 m) L, 3" (7.6cm) Diameter	8	90309	Table Base Only, 30" (76.0 cm) Diameter	5
9612	Column Only, 38" (96.5cm) L, 3" (7.6cm) Diameter	10	96339	Casing Only, 33" x 33" (83.8 x 83.8 cm)	2
9618	Rod Only, Steel, 26 3/4" (67.9cm) Length	50	9606	Leveling for Table Base(s), nickel plated bolt	100
9619	Nut Only	100	9617	Foot Ring, 19" (48.2 cm) Diameter	2
9620	Rod Only, Steel, 40 1/8" (102cm) Length	50			









**CROWN BRANDS**  
**STORAGE AND**  
**TRANSPORTATION**

Item #	Case	Page	Item #	Case	Page	Item #	Case	Page
31836	1	63	82433	1	68	91237	1	72
32436	1	63	82436	1	69	91243	1	72
81124	1	65	82436GUS	1	69			
81136	1	65	82437	1	69	96015	1	73
81148	1	65	82439	1	68	96019	10	73
81160	1	65	82448	1	69	96025	1	73
81172	1	65	82449	1	69	96029	5	73
81184	1	65	82451	1	68	96100	8	73
81196	1	65	82460	1	69	82436	1	69
81205	4	66	82461	1	69	82437	1	69
81215	4	66	82463	1	68	82439	1	68
81225	1	70	82472	1	69	82448	1	69
81226	1	70	82473	1	69	82449	1	69
81228	1	68	82475	1	68	996101	10	73
81231	1	70	82484	1	69	96120	8	73
81232	1	70	82487	1	68	96121	10	73
81233	1	68	82496	1	69	96225	1	73
81235	4	66	82499	1	68	96229	5	73
81237	1	70	83018	1	69	96305	1	73
81238	1	70	83018GUS	1	69	96309	5	73
81239	1	68	83019	1	69	96335	1	73
81249	1	70	83021	1	68	96339	2	73
81250	1	70	83030	1	69	98015	1	73
81251	1	68	83031	1	69	98025	1	73
81261	1	70	83033	1	68	98185	1	73
81262	1	70	83036	1	69	98225	1	73
81263	1	68	83036GUS	1	69	98245	1	73
81273	1	70	83037	1	69	98305	1	73
81274	1	70	83039	1	68	98335	1	73
81275	1	68	83048	1	69	98345	1	73
81285	1	70	83048GUS	1	69	118367	1	63
81286	1	70	83049	1	69	118368	1	63
81287	1	68	83052	1	68	118487	1	63
81297	1	70	83060	1	69	118488	1	63
81298	1	70	83060GUS	1	69	118607	1	63
81299	1	68	83061	1	69	118608	1	63
81328	1	68	83063	1	68	124367	1	63
81331	1	68	83072	1	69	124368	1	63
81337	1	68	83072GUS	1	69	124487	1	63
81349	1	68	83073	1	69	124488	1	63
81361	1	68	83075	1	68	124607	1	63
81373	1	68	83084	1	69	124608	1	63
81385	1	68	83085	1	69	218367	1	63
81397	1	68	83087	1	68	218368	1	63
81400	1	64	83096	1	69	218487	1	63
81401	1	64	83096GUS	1	69	218488	1	63
81424	1	65	83097	1	69	218607	1	63
81500	1	64	83099	1	68	218608	1	63
81501	1	64	83614	6	64	224367	1	63
81520	1	64	83622	6	64	224368	1	63
81624	1	65	83628	3	64	224487	1	63
81636	1	65	84023	2	66	224488	1	63
81648	1	65	84045	2	66	224607	1	63
81660	1	65	84814	6	64	224608	1	63
81672	1	65	84822	6	64	11072CA	4	62
81684	1	65	84828	6	64	11201WS	240	66
81696	1	65	86028	6	64	21064CA	4	61
81824	1	65	91111	1	72	21072CA	4	61
81825	1	70	91112	1	72	21084CA	4	61
81826	1	70	91113	1	72			
81831	1	70	91116	1	72			
81832	1	70	91117	1	72			
81837	1	70	91121	1	72			
81838	1	70	91122	1	72			
81849	1	70	91124	1	72			
81850	1	70	91126	1	72			
81861	1	70	91132	1	72			
81862	1	70	91134	1	72			
81873	1	70	91135	1	72			
81874	1	70	91136	1	72			
82312	1	70	91138	1	72			
82315	1	70	91143	1	72			
82318	1	70	91211	1	72			
82324	1	70	91212	1	72			
82330	1	70	91213	1	72			
82336	1	70	91216	1	72			
82348	1	70	91217	1	72			
82360	1	70	91221	1	72			
82372	1	70	91222	1	72			
82414	6	64	91223	1	72			
82424	1	69	91224	1	72			
82424GUS	1	69	91225	1	72			
82425	1	69	91232	1	72			
82427	1	68	91234	1	72			
82430	1	69	91235	1	72			
82431	1	69	91236	1	72			

## CROWN BRANDS, LLC

With Focus Foodservice, Johnson-Rose, Update International, and Co-Rect Products under the Crown Brands umbrella, we have the ability to provide our customers with quality driven products in a large array of categories. Focus Foodservice will promote innovation and smart solution items. Johnson-Rose provides great utility items like worktables and sinks. Update International is the leader in the industry for beverage dispensers and depth of products for both front and back of house. Co-Rect Products maintains the most comprehensive assortment of barware products in the industry.

## AUTOQUOTES

All of our brands will continue to grow and complement each other to give our customers the largest selection and options. We utilize the complete functionality of AutoQuotes. Products information, current list prices and specifying and quoting jobs quick and easy.

## FOCUS SHELVING ON



Easy to Search,  
Specify and Sell.

BIM | CAD | MOBILE

Focus Shelving have been converted to Revit 3D-based design software application for building and construction. The KCL platform distributes design content (symbols and families) with a focus on the foodservice industry.



## GREAT MERCHANDISING IDEAS

Easy ways to increase Cash and Carry sales

Not all foodservice products come in plain brown boxes. Crown Brands provides an assortment of Focus Foodservice and Johnson-Rose price point items from replacements and accessories to security module, cart and shelving kits! Our trilingual packaging designed to organize difficult to display products as well inform the consumer with detailed product specifications. More to come on Johnson-Rose packaging as well!



# The Single Source (2) Storage Solutions



JOHNSON-ROSE



scan: [www.crown-brands.com](http://www.crown-brands.com)

call: 800.968.3918  
fax: 800.968.4129



**CROWN BRANDS, LLC**

300 KNIGHTSBRIDGE PARKWAY, STE. 400  
LINCOLNSHIRE, ILLINOIS 60069

2018-19CBSTD-CAT  
0818

