

# 70

**Hatco**  
**ANNIVERSARY**  
**1950-2020**





People who serve,  
products that solve.®

### Export Price List

#### How to Order

To ensure prompt and accurate processing of your order, please provide the following information:

1. Model number, voltage, 50 and 60 Hertz and Phase, specify if CE Mark is required.
2. Specify options and accessories as required. Options are not retrofittable.
3. Consult factory when ordering equipment for special applications.
4. E-mail orders are acceptable and do not require confirmation.
5. See Resources section in back of book for more information.

**ALL WATT RATINGS ARE NOMINAL. ACTUAL WATTAGE MAY VARY. CONSULT FACTORY FOR MORE INFORMATION.**

Email orders to:  
intlsales@hatcocorp.com

Email inquiries and requests to:  
support@hatcocorp.com

Hatco Corporation  
P.O. Box 340500  
Milwaukee, WI 53234-0500 U.S.A.  
Telephone: (414) 671-6350  
www.hatcocorp.com

EX-Works  
Sturgeon Bay, WI 54235 U.S.A.

### Who We Are

Since 1950, Hatco has been a leader in creating innovative ideas for the foodservice industry: bold innovations in equipment that improves efficiency, reliability and profits. Products are designed and built to handle the rugged demands of today's foodservice operations. Hatco is a company dedicated to exceptional customer service and quality engineered equipment offering maximum performance.

### We Pride Ourselves On Being Employee Owned

The company was started by Gordon and LaReine Hatch in 1950 and was led by their son, David, beginning in 1990. In 2004, Hatco Corporation began the journey of employee ownership, and in 2007, a monumental event in Hatco history occurred: the employees assumed 100% ownership from David Hatch! Hatco still remains a family corporation - only now our family is larger. The employee owners are driven by the spirit of ownership and motivated by the empowerment of ownership.

### Equipment

Booster Water Heaters	Frost Tops	Nacho Chip Warmers
Built-In Shelves	Fry Stations	Pizza Warmers
Built-In Warmers	Heated Shelves	Portable Warmers
Carving Stations	Heated Wells	Refrigerated Wells
Cold Shelves	Holding and Display Cabinets	Rethermalizers
Cold Wells	Hot/Cold Shelves	Sanitizing Sink Heaters
Commercial Toasters	Hot Food Merchandisers	Snack System
Decorative Lamps	Ice Wells	Soup Stations
Display Lights	Induction	Strip Heaters
Drawer Warmers	Light Cooking Equipment	

### Locations



**Milwaukee - Corporate Office**  
635 South 28th St. | Milwaukee, WI 53215  
414-671-6350



**Sturgeon Bay - Manufacturing Facility**  
208 East Deck Street | Sturgeon Bay, WI 54235  
920-743-5595



### Let's Get Social





## TABLE OF CONTENTS

<b>WELLS</b>	2-35	<b>DRAWER WARMERS</b>	115-119
<b>DECORATIVE LAMPS &amp; DISPLAY LIGHTS</b>	36-45	<b>MERCHANDISERS</b>	120-134
<b>STRIP HEATERS</b>	46-74	<b>HOLDING &amp; DISPLAY CABINETS</b>	135-151
<b>FRY STATIONS</b>	75-80	<b>TOASTERS</b>	152-158
<b>CARVING STATIONS</b>	81-83	<b>INDUCTION</b>	159-161
<b>PORTABLES</b>	84-96	<b>LIGHT COOKING EQUIPMENT</b>	162-165
<b>BUILT-INS</b>	97-114	<b>WATER HEATING/SPECIALTY EQUIPMENT</b>	166-177

3CS	167
C	169-170
CDW	116
Chef LED <b>NEW</b>	45
CSBF, CSBFR, CSBFX	101-102
CSSB, CSSBR CSSBX	98
CSSBF, CSSBFR, CSSBFX	99-100
CSU, CSUR, CSUX	103-104
CWB, CWB-S	6-8, 12
CWBR, CWBR-S, CWBX, CWBX-S	9-12
DCS	82
DL, DLH	37-42
FDWD-1-MN	145
FDWD	136, 139-140
FR	168
FS2HAC	151
FSD, FSDT	137-140
FSHAC	151
FSHC-5W	147
FSHC-6W	149
FSHC-7W	147
FSHC-7	150
FSHC-12W	148
FSHC-17W	148
FST-1-MN	145
FTB, FTB-S	13-14
FTBR, FTBX	15-16
GR, GRH	53-54
GR2A, GR2AH	63, 65
GR2A-xxD, GR2AH-xxD	66, 68
GR2AL, GR2AHL	64-65
GR2AL-xxD, GR2AHL-xxD	67-68
GR2BW	95-96
GR2S	89
GR2SDH, GR2SDH-xxD	125-126
GR2SDS, GR2SDS-xxD	125-126
GR3SDS-39DCT, GR3SDS-39TCT	129
GR5A GR5AH <b>NEW</b>	49
GR5AL, GR5AHL <b>NEW</b>	50-51
GRA, GRAH	52, 54

GRA-xxD, GRAH-xxD	55, 57
GRAL, GRAHL	53-54
GRAL-xxD, GRAHL-xxD	56-57
GRAIH, GRAIHL	60, 62
GRAIH-xxD, GRAIHL-xxD	61-62
GR-B	76-77
GRBW	95-96
GRCD, GRCDH	131-132
GRCMW	130
GRCSC, GRCSC LH	83
GRFF, GRFFL, GRFFB, GRFFBL	76-77
GRFHS	79-80
GRFS	79-80
GRHD, GRHDH	133-134
GRHW	94
GRN, GRNH	58-59
GRPWS	121
GRS	87-89
GRSB	113
GRSBF	114
GRSDH, GRSDH-xxD	123-124
GRSDS, GRSDS-xxD	123-124
GRSDS/H	122
GRSR	86
GRSS	92
GRSSB	110
GRSSR	90-91
HGB	93
HGBB, HGBBH	111, 112
HCSBF, HCSBFR, HCSBFX	108-109
HCSSB, HCSSBR, HCSSBX	105
HCSSBF, HCSSBFR, HCSSBFX	106-107
HDW	117-119
HL	43
HL5 <b>NEW</b>	44
HW	3
HWB, HWBQ <b>NEW</b>	24-27, 34-35
HWB-, HWBI-xQT	28-29, 34-35
HWBI, HWBI43 <b>NEW</b>	17-19, 34-35
HWBI-S	20-21, 34-35

HWBRN, HWBRNQ <b>NEW</b>	30-32, 34-35
HWBRT, HWBRTQ <b>NEW</b>	30-32, 34-35
HWBRN-xQT	33-35
HWBRT-xQT	33-35
HXMH, HXMH-xxD	127-128
HXMS, HXMS-xxD	127-128
IHDCH <b>NEW</b>	141-142
IRNG-PC1, -PB1	159-161
ITQ <b>NEW</b>	153
IWB, IWB-S	4-5, 12
LW	85
MDW	144
MPWS	78
PFST	146
RMB	74
S	171-172
SAL	164
SNACK <b>NEW</b>	163
TF	165
TFW	165
TK	157-158
TQ	155-156, 158
TQ3	154
UGA, UGAH	69, 71
UGA-xxD, UGAH-xxD	70-71
UGAL, UGAHL	69, 71
UGAL-xxD, UGAHL-xxD	70-71
UGFF, UGFFL, UGFFB, UGFFBL	76-77
WFST	143



# Wells

*Cafeterias • Buffets  
Convenience Stores • Supermarkets & Delis  
Restaurants & Cafés • Clubs & Bars*



**HW-FUL** with accessory pan support bars (food pans, ladles and lids not available) *pg. 3*



**IWB-6** with accessory food pan (sneeze guards and bowls not available) *pg. 4*



**CWB-3** with accessory food pans *pg. 7*



**CWB-S4** with optional **CWB-S4SLANT**, accessory pan support bars and food pans *pg. 8*



**FTB-2** with accessory full-size sheet pans *pg. 14*



**HWBI-2** with accessory half- and third-size food pans (sneeze guards not available) *pg. 18*



**HWBI-3MA** with accessory food pans *pg. 18*



**HWBI-S4MA** with accessory food pans (shown with **GRAH-72**, sneeze guards not available) *pg. 21*



**HWBRT-7QTD** and **HWBRT-11QTD** with accessory food pans and mounting kit (also shown **HWB-43D** and **HWBI-FULD**) *pg. 33, 27, -24*



## Countertop Heated Wells

Providing versatility and reliability, Hatco Countertop Heated Wells hold food hot and fresh in either a wet or dry operation with an adjustable temperature control. The HW-FUL unit can hold a full-size pan or three third-size pans.

- Controls feature a separate lighted On/Off rocker switch and adjustable temperature dial
- May be used dry but best performance when used with water. Dry indicator lamp informs user to add water
- Thicker .8 mm stainless steel pan with a stainless steel housing (aluminized steel bottom)
- Pan edge offset helps keep condensation from dripping onto countertop surface



HW-FUL with accessory food pans and pan support bar

### HOLD ONLY COUNTERTOPS – FULL-SIZE AND 4/3-SIZE

Model	Dimensions (W x D x H)	Voltage	Watts	Plug	Ship Weight	List Price
<b>Standard Watt</b>						
HW-FUL	368 x 607 x 248 mm	220 230 <sup>†</sup>	1100 1200	BS 1363 BS 1363, CEE 7/7, AS 3112, CCC	13 kg	<b>\$495</b>

<sup>†</sup> 230V available with CE Mark, at no added charge.

**All Hold Only Countertop Heated Well Models Feature:**

**Voltage:** Single phase only.

**Cord Location:** Bottom left corner on back of unit.

**Models Shipped with:** Stainless steel pan, stainless steel (aluminized stainless steel bottom) housing with a metal sheathed heating element, a power On/Off switch, a temperature control, a dry unit indicator light and a 1829 mm cord with plug attached.

### ACCESSORIES (available for purchase at any time)

HW-2-7QT	Adapter to convert warmer to hold two 7-Liter Inserts (model HW-FUL only)	<b>\$76</b>
HW-3-4QT	Adapter to convert warmer to hold three 4-Liter Inserts (model HW-FUL only)	<b>76</b>
HW12BAR	305 mm Pan Support for Countertop Wells	<b>16</b>
HW20BAR	508 mm Pan Support for Countertop Wells	<b>19</b>

### ADDITIONAL PAN AND LID ACCESSORIES – PAGE 34-35

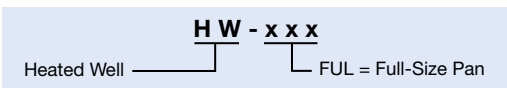



## Drop-In Ice Wells

Hatco Drop-In Slim Ice Wells provide all the quality features of our Refrigerated Drop-Ins, but without any refrigeration or electrical components. These ice-cooled, insulated units can hold prechilled food products at preferred serving temperatures. Ideal for salad bars, cold buffets and chilled beverage bars. Pan dividers give you greater flexibility in your variety of featured food products.

- Full-size, insulated, top mount wells available to hold 1- to 6-pan configurations
- Optimal insulation on sides and bottom to ensure better cold retention and cost savings

- Bezel design allows clear viewing and easy food access
- Larger 1" NPT brass drain with flat screen simplifies cleaning
- False bottom accessory conveniently holds ice above drain for ease of draining
- Matches the Hatco line of Wells for a fully integrated look



IWB-4



IWB-2 with slant option IWB-2SLANT

### DROP-IN INSULATED ICE WELLS

Model	Dimensions W x D x H	Ship Weight	List Price
IWB-1	483 x 686 x 305 mm	22 kg	\$1364
IWB-2	813 x 686 x 305 mm	27 kg	1572
IWB-3	1143 x 686 x 305 mm	37 kg	1821
IWB-4	1473 x 686 x 305 mm	43 kg	2111
IWB-5	1803 x 686 x 305 mm	50 kg	2442
IWB-6	2134 x 686 x 305 mm	50 kg	2814

CE Mark not available.

### OPTIONS (available at time of purchase only)

IWB-1SLANT	Slant Option for IWB-1	\$200
IWB-2SLANT	Slant Option for IWB-2	216
IWB-3SLANT	Slant Option for IWB-3	233
IWB-4SLANT	Slant Option for IWB-4	249
IWB-5SLANT	Slant Option for IWB-5	266
IWB-6SLANT	Slant Option for IWB-6	282

### ACCESSORIES (available for purchase at any time)

**False Bottoms (allows for 89 mm of ice and sits on ledge of well) –**

1FB3.5	For IWB-1 models (includes one 1-pan Insert)	\$ 75
2FB3.5	For IWB-2 models (includes one 2-pan Insert)	138
3FB3.5	For IWB-3 models (includes one 1-pan Insert and one 2-pan Insert)	201
4FB3.5	For IWB-4 models (includes two 2-pan Insert)	264
5FB3.5	For IWB-5 models (includes one 1-pan Insert and two 2-pan Inserts)	327
6FB3.5	For IWB-6 models (includes three 2-pan Inserts)	390

**False Bottoms (allows for 203 mm of ice and sits on bottom of well) –**

1FB8	For IWB-1 models (includes one 1-pan Insert)	\$ 75
2FB8	For IWB-2 models (includes one 2-pan Insert)	138
3FB8	For IWB-3 models (includes one 1-pan Insert and one 2-pan Insert)	201
4FB8	For IWB-4 models (includes two 2-pan Insert)	264
5FB8	For IWB-5 models (includes one 1-pan Insert and two 2-pan Inserts)	327
6FB8	For IWB-6 models (includes three 2-pan Inserts)	390

### ADDITIONAL PANS AND SUPPORT BAR ACCESSORIES – PAGE 12

### DROP-IN ICE WELL COUNTERTOP CUT-OUTS

Model	Minimum Width	Maximum Width	Minimum Depth	Maximum Depth
IWB-1	435 mm	457 mm	640 mm	660 mm
IWB-2	765 mm	787 mm	640 mm	660 mm
IWB-3	1095 mm	1118 mm	640 mm	660 mm
IWB-4	1426 mm	1448 mm	640 mm	660 mm
IWB-5	1756 mm	1778 mm	640 mm	660 mm
IWB-6	2086 mm	2108 mm	640 mm	660 mm

Slant Option for:  
IWB-1, -2, -3, -4, -5, -6

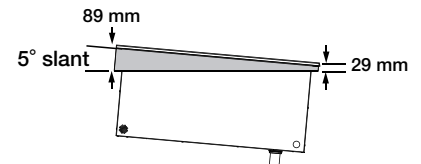

3FB3.5  
Accessory

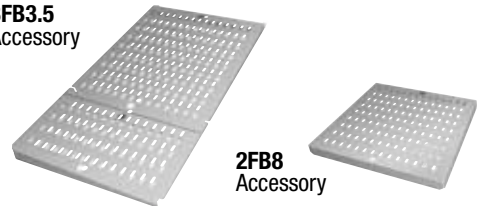

2FB8  
Accessory

### False Bottom Accessories

1-part, 2-part or 3 part(s) depending on pan size

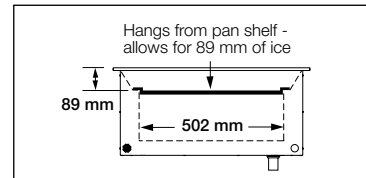

(1, 2, 3, 4, 5 or 6FB3.5) allows 89 mm of ice

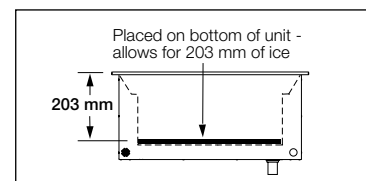

(1, 2, 3, 4, 5 or 6FB8) allows 203 mm of ice

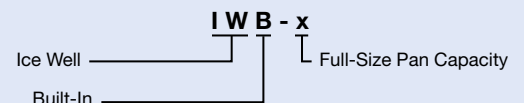



## Drop-In Slim Ice Wells

Hatco Drop-In Ice Slim Wells provide all the quality features of our Refrigerated Drop-Ins, but without any refrigeration or electrical components. Now available in a slim configuration providing customers with a complete well within easy reach, regardless of the sneeze guards.

Ideal for salad bars, cold buffets and chilled beverage bars. Pan dividers give you greater flexibility in your variety of featured food products.

- Holds 1- to 4-full-size pan configurations, but placed lengthwise
- Optimal insulation on sides and bottom to ensure better cold retention and cost savings
- Bezel design allows clear viewing and easy food access
- Larger 1" NPT brass drain with flat screen simplifies cleaning
- False bottom accessory conveniently holds ice above drain for ease of draining
- Matches the Hatco line of Wells for a fully integrated look

IWB-S4 with optional slant kit



IWB-S2



### DROP-IN INSULATED SLIM ICE WELLS

Model	Dimensions W x D x H	Ship Weight	List Price
IWB-S1	687 x 481 x 306 mm	22 kg	\$1416
IWB-S2	1222 x 481 x 306 mm	48 kg	1624
IWB-S3	1757 x 481 x 306 mm	40 kg	1873
IWB-S4	2292 x 481 x 306 mm	52 kg	2163

CE Mark not available.

### OPTIONS (available at time of purchase only)

IWB-S1SLANT	Slant Option for IWB-S1	\$200
IWB-S2SLANT	Slant Option for IWB-S2	216
IWB-S3SLANT	Slant Option for IWB-S3	233
IWB-S4SLANT	Slant Option for IWB-S4	249

### ACCESSORIES (available for purchase at any time)

**False Bottoms for Slim Ice Wells (allows for 89 mm of ice and sits on ledge of well) –**

1FBS3.5	For IWB-S1 models (includes one 1-pan Insert)	\$ 75
2FBS3.5	For IWB-S2 models (includes one 2-pan Insert)	138
3FBS3.5	For IWB-S3 models (includes one 1-pan Insert and one 2-pan Insert)	201
4FBS3.5	For IWB-S4 models (includes two 2-pan Inserts)	264

**False Bottoms for Slim Ice Wells (allows for 203 mm of ice and sits on bottom of well) –**

1FBS8	For IWB-S1 models (includes one 1-pan Insert)	\$ 75
2FBS8	For IWB-S2 models (includes one 2-pan Insert)	138
3FBS8	For IWB-S3 models (includes one 1-pan Insert and one 2-pan Insert)	201
4FBS8	For IWB-S4 models (includes two 2-pan Inserts)	264

### ADDITIONAL PANS AND SUPPORT BAR ACCESSORIES – PAGE 12

#### Slant Option for:

IWB-S1, -S2, -S3, -S4

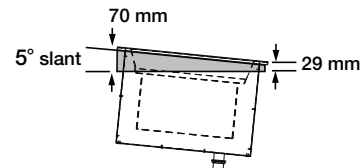

#### False Bottom Accessories

1-part, 2-part or 3 part(s) depending on pan size

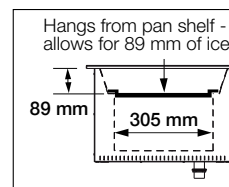

(1, 2, 3 or 4FBS3.5) for the IWB-S Series

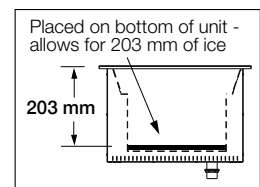

(1, 2, 3 or 4FBS8) for the IWB-S Series

### DROP-IN SLIM ICE WELLS COUNTERTOP CUT-OUTS

Model	Minimum Width	Maximum Width	Minimum Depth	Maximum Depth
IWB-S1	641 mm	662 mm	433 mm	456 mm
IWB-S2	1175 mm	1196 mm	433 mm	456 mm
IWB-S3	1710 mm	1731 mm	433 mm	456 mm
IWB-S4	2245 mm	2266 mm	433 mm	456 mm

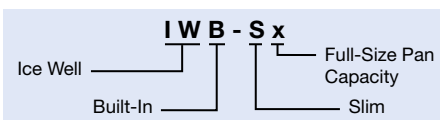



# Refrigerated Drop-In Wells Ordering Instructions

Cutaway of CWB-6 with accessory food pans

**NSF 7 Component** approved cold wall construction keeps food product cold without drying it out

A Refrigerated Well can house a variety of pans – full-size, half-size or third-size – showcasing a variety of your food products

The greater surface area of the angled wall and the placement of the coils allow cold air to more effectively blanket your food product

The unique top bezel design also provides easy access and clear views

76 mm

Larger brass drain ensures easy cleaning

Exclusive flat screen design ensures that pans sit flush

Adjustable condensing unit can rotate 90° or 180° on all models for easy venting adjustments and flexible installation

Mobile condensing unit can be moved in 165 mm increments from end to center on the 4-, 5-, and 6-pan units

The well cavity ensures energy efficiency with environmentally-friendly insulation used throughout

Long, flexible refrigerant lines for easy pull-out and service

Easy-to-service pull-out design

Auto-defrost activated through an advanced electronic controller programmed at the customer location

**Please specify the following with each order:**

1. **Desired Voltage:**  
220-240V
2. **Number of Drop-In Wells Required:**
  - A. 1-, 2-, 3-, 4-, 5- or 6-pan as rectangular, full-size (305 mm x 508 mm)
  - B. Slim configuration  
S1-, S2-, S3- or -S4-pan as rectangular, full-size (305 mm x 508 mm)
3. **Depth of Model:** Standard configuration 686 mm or Slim configuration 481 mm
4. **Agency – NSF 7 Component**
5. **Electronic Control Assembly** can be mounted on either side of the Condensing Unit or remotely mounted up to 1219 mm from the unit (cannot be mounted over the Condensing Unit)

**Option**

1. Slant Option for CWB-1, -2, -3, -4, -5, -6 or CWB-S1, -S2, -S3, -S4

**Accessories**

1. **Pan Support Bars:** 305 mm x 508 mm
2. **Stainless Steel Pans:**
  - A. Third-size at 64 mm deep (324 W x 175 D x 64 H mm)
  - B. Half-size at 64 mm deep (324 W x 264 D x 64 H mm)
  - C. Full-size at 64 mm deep (324 W x 527 D x 64 H mm)
  - D. Full-size at 102 mm deep (324 W x 527 D x 102 H mm)
  - E. Full-size at 152 mm deep (324 W x 527 D x 152 H mm)
3. **Perforated False Bottom**

From below, you can see the condenser unit after being pulled out by the technician, allowing easy access and visibility to all service components



The sight glass gives an inside look into a usually closed system to determine if the refrigerant is low or if there is water in the system

**ACCESSORIES – PAGE 12**

**REFRIGERATED DROP-IN WELLS COUNTERTOP CUT-OUTS**

Model	Minimum Width	Maximum Width	Minimum Depth	Maximum Depth
CWB-1	435 mm	457 mm	640 mm	660 mm
CWB-2	765 mm	787 mm	640 mm	660 mm
CWB-3	1095 mm	1118 mm	640 mm	660 mm
CWB-4	1426 mm	1448 mm	640 mm	660 mm
CWB-5	1756 mm	1778 mm	640 mm	660 mm
CWB-6	2086 mm	2108 mm	640 mm	660 mm
<b>Slim Series</b>				
CWB-S1	641 mm	662 mm	433 mm	456 mm
CWB-S2	1175 mm	1196 mm	433 mm	456 mm
CWB-S3	1710 mm	1731 mm	433 mm	456 mm
CWB-S4	2245 mm	2266 mm	433 mm	456 mm





## Refrigerated Drop-In Wells

Hatco's Refrigerated Drop-In Well is a full-size unit that blankets your pre-chilled food product to retain optimum freshness and taste in one efficient and easy operation – a winner for your foodservice operation.

- Full-size, insulated wells available in 1- to 6-pan configurations
- NSF 7 Component approved cold wall construction keeps food cold without drying it out
- Electronic control assembly can be mounted on either side of the condensing unit or remotely mounted up to 1219 mm
- Adjustable condensing unit can be rotated 90° or 180° on all models for easy venting and flexibility at installation
- Mobile condensing unit may be moved in 165 mm increments between the center line and the factory-installed compressor location in the 4-, 5- and 6-pan units
- Auto-defrost is activated through an advanced electronic controller programmed at the customer location
- Optimal insulation on sides and bottom to ensure better cold retention. Environmentally-friendly insulation used throughout
- Easy serviceability with a sight glass, service valves, dryer and a receiver. Long, flexible refrigerant line (ability to pull out condensing unit) for service
- 1" NPT brass drain simplifies cleaning



**CWB-3** with accessory food pans and pan support bars

**CWB-2** with slant option **CWB-2SLANT**



### DROP-IN FULL-SIZE INSULATED RECTANGULAR MODELS

Model	Dimensions W x D	Price List
<b>CWB-1</b>	483 x 686	<b>\$5629</b>
<b>CWB-2</b>	813 x 686	<b>5974</b>
<b>CWB-3</b>	1143 x 686	<b>6386</b>
<b>CWB-4</b>	1473 x 686	<b>6817</b>
<b>CWB-5</b>	1803 x 686	<b>7372</b>
<b>CWB-6</b>	2134 x 686	<b>7793</b>

CE Mark not available.

**All Refrigerated Drop-In Well Models Feature:**

**Voltage:** 220-240V, single phase.

**Models Shipped with:** Electronic temperature control, pan support bars for full-size pans, condensing unit (can be rotated), auto-defrost, sight glass, service valves and dryer.

**Consult Factory for:** height dimensions, HP, watts, shipping and refrigerant specifications.

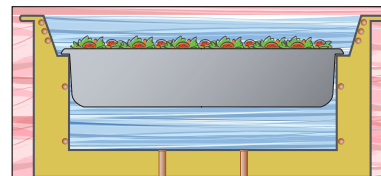

The unique angled inside wall design provides easy access and clear views. The greater surface area of the angled wall and the placement of the coils allow cold air to more effectively blanket your food product.

### OPTIONS (available at time of purchase only)

<b>CWB-1SLANT</b>	Slant Option for CWB-1	<b>\$247</b>
<b>CWB-2SLANT</b>	Slant Option for CWB-2	<b>264</b>
<b>CWB-3SLANT</b>	Slant Option for CWB-3	<b>280</b>
<b>CWB-4SLANT</b>	Slant Option for CWB-4	<b>297</b>
<b>CWB-5SLANT</b>	Slant Option for CWB-5	<b>313</b>
<b>CWB-6SLANT</b>	Slant Option for CWB-6	<b>330</b>

### COUNTERTOP CUT-OUT DIMENSIONS – PAGE 6 ACCESSORIES – PAGE 12

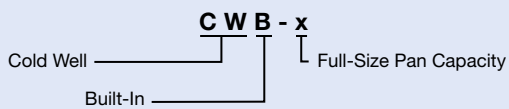
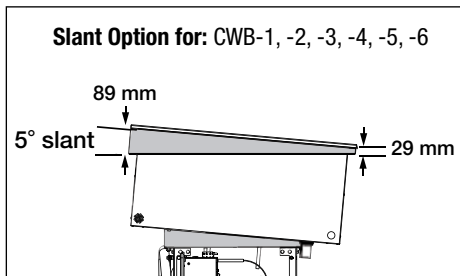



## Refrigerated Slim Drop-In Wells

Hatco's Refrigerated Slim Drop-In Well is a full-size unit that blankets your pre-chilled food product to retain optimum freshness and taste in one efficient and easy operation – but placed lengthwise. This provides customers with a complete cold well within easy reach, regardless of the sneeze guards.

- Insulated wells available in 1- to 4-full-size pan configurations
- NSF 7 Component approved cold wall construction keeps food product cold without drying it out
- Adjustable condensing unit can rotate 180° on all models for easy venting adjustments and flexibility at installation
- Mobile condensing unit can be moved in 123 mm increments from left end to center on the 2-, 3- and 4-pan units (CWB-S1 is rotatable only)
- Easy serviceability with a sight glass, service valves, dryer/filter and a receiver. Long, flexible refrigerant line (ability to pull out condensing unit) for service
- Auto-defrost is activated through an advanced electronic controller programmed at customer location
- Optimal insulation on sides and bottom ensure better cold retention
- 1" NPT brass drain simplifies cleaning

**CWB-S2**  
with accessory (hotel) food pans and additional pan support bars



**CWB-S4**  
with optional slant kit, accessory (hotel) food pans and additional pan support bars

### REFRIGERATED SLIM DROP-IN WELLS

Model	Dimensions	List Price
	W x D	
<b>CWB-S1</b>	687 x 481	<b>\$5629</b>
<b>CWB-S2</b>	1222 x 481	<b>6139</b>
<b>CWB-S3</b>	1757 x 481	<b>7033</b>
<b>CWB-S4</b>	2292 x 481	<b>8401</b>

CE Mark not available.

#### All Refrigerated Slim Drop-In Well Models Feature:

**Voltage:** 220-240V, single phase.

**Models Shipped with:** Electronic temperature control, pan support bars for full-size pans, condensing unit (can be rotated 180°), auto-defrost, sight glass, service valves and dryer.

**Consult Factory for:** height dimensions, HP, watts, shipping and refrigerant specifications.

#### OPTIONS (available at time of purchase only)

<b>CWB-S1SLANT</b>	Slant Option for CWB-S1	<b>\$220</b>
<b>CWB-S2SLANT</b>	Slant Option for CWB-S2	<b>237</b>
<b>CWB-S3SLANT</b>	Slant Option for CWB-S3	<b>253</b>
<b>CWB-S4SLANT</b>	Slant Option for CWB-S4	<b>270</b>

**COUNTERTOP CUT-OUT DIMENSIONS – PAGE 6**  
**ACCESSORIES – PAGE 12**

#### Slant Option for CWB-S1, S2, S3, S4

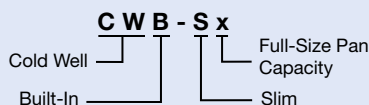
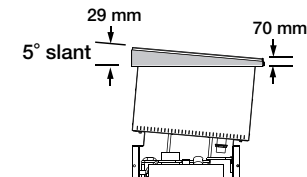



## Remote Refrigerated Drop-In Wells Ordering Instructions

Cutaway of **CWBR-6** with accessory food pans

Cold Well with: Temperature Probe

NSF 7 Component approved cold wall construction keeps food product cold without drying it out

A Refrigerated Well can house a variety of pans – full-size, half-size or third-size – showcasing a variety of your food products

The greater surface area of the angled wall and the placement of the coils allow cold air to more effectively blanket your food product

The unique top bezel design also provides easy access and clear views

Larger brass drain ensures easy cleaning  
Exclusive flat screen design ensures that pans sit flush

Auto-defrost activated through an advanced electronic controller programmed at the customer location



**CWBR:** with a Condensing Unit  
**CWBX:** without a Condensing Unit

The well cavity ensures energy efficiency with environmentally-friendly insulation used throughout

Please specify the following with each order:

- Desired Voltage:**  
220-240V
- Number of Drop-In Wells Required:**
  - 1-, 2-, 3-, 4-, 5- or 6-pan as rectangular, full-size (305 mm x 508 mm)
  - Slim configuration  
S1-, S2-, S3- or -S4-pan as rectangular, full-size (305 mm x 508 mm)
- Depth of Model:** Standard configuration 686 mm or Slim configuration 481 mm
- Remote Refrigeration**  
**NOTE:** Shipped loose: Cold Well with Temperature Probe, Control Panel (Probe Wires are 4.9 meters and a TXV Valve)
  - CWBR** with a Condensing Unit – may be field mounted up to 15 meters of tubing from the unit (shipped loose)
  - CWBX** without a Condensing Unit (Solenoid Valve attached to Cold Well)
- Agency** – NSF 7 Component

**Option**

- Slant Option for CWBR- or CWBX-1, -2, -3, -4, -5, and -6 or -S1, -S2, -S3, -S4

**Accessories**

- Pan Support Bars:** 305 mm or 508 mm
- Stainless Steel Pans:**
  - Third-size at 64 mm deep (324 W x 175 D x 64 H mm)
  - Half-size at 64 mm deep (324 W x 264 D x 64 H mm)

- Full-size at 64 mm deep (324 W x 527 D x 64 H mm)
- Full-size at 102 mm deep (324 W x 527 D x 102 H mm)
- Full-size at 152 mm deep (324 W x 527 D x 152 H mm)

**3. Perforated False Bottom**

**4. Trivets:**

- Half-size  
259 W x 194 D mm
- Full-size  
259 W x 457 D mm

### REMOTE REFRIGERATED DROP-IN WELLS COUNTERTOP CUT-OUTS

Model	Minimum Width	Maximum Width	Minimum Depth	Maximum Depth
<b>CWBR-1, CWBX-1</b>	435 mm	457 mm	640 mm	660 mm
<b>CWBR-2, CWBX-2</b>	765 mm	787 mm	640 mm	660 mm
<b>CWBR-3, CWBX-3</b>	1095 mm	1118 mm	640 mm	660 mm
<b>CWBR-4, CWBX-4</b>	1426 mm	1448 mm	640 mm	660 mm
<b>CWBR-5, CWBX-5</b>	1756 mm	1778 mm	640 mm	660 mm
<b>CWBR-6, CWBX-6</b>	2086 mm	2108 mm	640 mm	660 mm
<b>Slim Series</b>				
<b>CWBR-S1, CWBX-S1</b>	641 mm	662 mm	433 mm	456 mm
<b>CWBR-S2, CWBX-S2</b>	1175 mm	1196 mm	433 mm	456 mm
<b>CWBR-S3, CWBX-S3</b>	1710 mm	1731 mm	433 mm	456 mm
<b>CWBR-S4, CWBX-S4</b>	2245 mm	2266 mm	433 mm	456 mm

**ACCESSORIES – PAGE 12**





## Remote Refrigerated Drop-In Wells

Hatco's Remote Refrigerated Drop-In Wells keep pre-chilled food products at safe-serving temperatures but in a remote configuration that offers unlimited flexibility for your own particular dining design needs.

- Full-size, insulated wells available in 1- to 6-pan configurations
- NSF 7 Component approved cold wall construction keeps food cold without drying it out
- Optimal insulation on sides and bottom to ensure better cold retention. Environmentally-friendly insulation used throughout
- CWBR models include a condensing unit (shipped loose, can be field mounted up to 15 meters of tubing from unit) and control panel (shipped loose - probe wires are 5 meters) for installing in more convenient or desirable locations
- CWBX model include a control panel (shipped loose - probe wires are 4.9 meters) but without a condensing unit for the increased flexibility of multiple cold well configurations
- Auto-defrost is activated through an advanced electronic controller programmed at the customer location
- 1" NPT brass drain simplifies cleaning

**CWBR-6** with accessory food pans and pan support bars



Control panel and a condensing unit (shipped loose)

### REMOTE REFRIGERATED DROP-IN FULL-SIZE MODELS – WITH CONDENSING UNIT AND REMOTE CONTROL PANEL

Model	Dimensions (W x D x H)	List Price
CWBR-1	483 x 686 x 305 mm	\$5028
CWBR-2	813 x 686 x 305 mm	5372
CWBR-3	1143 x 686 x 305 mm	5783
CWBR-4	1473 x 686 x 305 mm	6211
CWBR-5	1803 x 686 x 305 mm	6764
CWBR-6	2134 x 686 x 305 mm	7183

CE Mark not available.

**All Remote Refrigerated Drop-In Well Models with Condensing Unit and Remote Control Panel Feature:**

Voltage: 220-240V, single phase.

Models Shipped with: Electronic temperature control, condensing unit and TXV valve (all shipped loose).

Consult Factory for: HP, watts, shipping and refrigerant specifications.

### REMOTE REFRIGERATED DROP-IN FULL-SIZE MODELS – WITH REMOTE CONTROL PANEL

Model	Dimensions (W x D x H)	List Price
CWBX-1	483 x 686 x 433 mm	\$3664
CWBX-2	813 x 686 x 433 mm	4007
CWBX-3	1143 x 686 x 433 mm	4417
CWBX-4	1473 x 686 x 433 mm	4673
CWBX-5	1803 x 686 x 433 mm	5042
CWBX-6	2134 x 686 x 433 mm	5460

CE Mark not available.

**All Remote Refrigerated Drop-In Well Models with Remote Control Panel Feature:**

Voltage: 220-240V, single phase.

Models Shipped with: Electronic temperature control, TXV valve (shipped loose) and a solenoid valve attached to well.

Consult Factory for: HP, watts, shipping and refrigerant specifications.

**CWBX-6** with accessory food pans and pan support bars



Control panel (shipped loose)

### OPTIONS (available at time of purchase only)

CWBR-1SLANT	Slant Option for CWBR-1, CWBX-1	\$200
CWBR-2SLANT	Slant Option for CWBR-2, CWBX-2	216
CWBR-3SLANT	Slant Option for CWBR-3, CWBX-3	233
CWBR-4SLANT	Slant Option for CWBR-4, CWBX-4	249
CWBR-5SLANT	Slant Option for CWBR-5, CWBX-5	266
CWBR-6SLANT	Slant Option for CWBR-6, CWBX-6	282



CWBX-2 with slant option  
CWBX-2SLANT

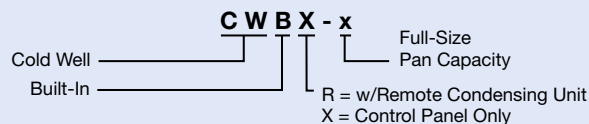

**COUNTERTOP CUT-OUT DIMENSIONS – PAGE 9**  
**ACCESSORIES – PAGE 12**

## Remote Refrigerated Slim Drop-In Wells

Hatco's Remote Refrigerated Slim Drop-In Well is a full-size unit that blankets your pre-chilled food product to retain optimum freshness and taste in one efficient and easy operation – but placed lengthwise and in two remote configurations. This provides customers with a complete cold well within easy reach, regardless of the sneeze guards and unlimited flexibility for your design needs.

- Full-size, Insulated wells available in 1 to 4 full-size pan configurations
- NSF 7 Component approved cold wall construction (CWBR-S only), keeps food product cold without drying it out
- Optimal insulation on sides and bottom to ensure better cold retention. Environmentally-friendly insulation used throughout
- CWBR-S models include a condensing unit (shipped loose, can be field mounted up to 15.24 meters of tubing from unit) and control panel (shipped loose - probe wires are 4.9 meters) for installing in more convenient or desirable locations
- CWBX-S model include a control panel

(shipped loose - probe wires are 4.9 meters) but without a condensing unit for the increased flexibility of multiple cold well configurations

- Easy serviceability with a sight glass, service valves, dryer and a receiver (CWBR-S models only)
- Auto-defrost is activated through an advanced electronic controller programmed at customer location
- Optimal insulation on sides and bottom ensure better cold retention
- 1" NPT brass drain simplifies cleaning



**CWBR-S4** with accessory (hotel) food pans and additional support bars

Condensing unit (shipped loose)

Control panel (shipped loose)



**CWBX-S2** with accessory (hotel) food pans and additional support bars



Control panel (Shipped loose)

### REMOTE REFRIGERATED SLIM DROP-IN FULL-SIZE MODELS – WITH CONDENSING UNIT AND REMOTE CONTROL PANEL

Model	Dimensions (W x D x H)	List Price
CWBR-S1	687 x 481 x 305 mm	4890
CWBR-S2	1222 x 481 x 305 mm	5383
CWBR-S3	1757 x 481 x 305 mm	6248
CWBR-S4	2292 x 481 x 305 mm	7571

### REMOTE REFRIGERATED SLIM DROP-IN FULL-SIZE MODELS – WITH REMOTE CONTROL PANEL

Model	Dimensions (W x D x H)	List Price
CWBX-S1	687 x 481 x 435 mm	\$3664
CWBX-S2	1222 x 481 x 435 mm	4171
CWBX-S3	1757 x 481 x 435 mm	5059
CWBX-S4	2292 x 481 x 435 mm	6247

#### All Remote Refrigerated Slim Drop-In Well Models with Condensing Unit and Remote Control Panel Feature:

Voltage: 220/230/240V, single phase.

Models Shipped with: Electronic temperature control, condensing unit and TXV valve (all shipped loose).

Consult Factory for: HP, watts, shipping and refrigerant specifications.

#### All Remote Refrigerated Slim Drop-In Well Models with Remote Control Panel Feature:

Voltage: 220/230/240V, single phase

Models Shipped with: Electronic temperature control, TXV valve (all shipped loose) and a soleoid valve attached to the well.

Consult Factory for: HP, watts, shipping and refrigerant specifications.

#### OPTIONS (available at time of purchase only)

EWC	Additional Four Year Parts Only Warranty on the Compressor	\$200
CWB-S1SLANT	Slant Option for CWBR-S1, CWBX-S1	220
CWB-S2SLANT	Slant Option for CWBR-S2, CWBX-S2	237
CWB-S3SLANT	Slant Option for CWBR-S3, CWBX-S3	253
CWB-S4SLANT	Slant Option for CWBR-S4, CWBX-S4	270

#### Slant Option for CWB-S1, S2, S3, S4

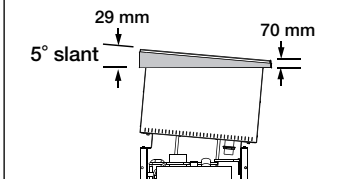

#### COUNTERTOP CUT-OUT DIMENSIONS – PAGE 9 ACCESSORIES – PAGE 12

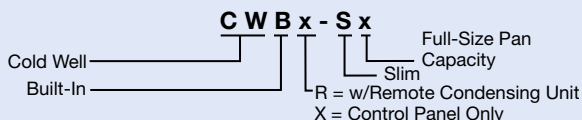





**Refrigerated Drop-In Well Accessories** (available for purchase at any time)



**CWB-2** with optional **CWB-2SLANT** and accessory food pans and pan support bars

**PANS – TRIVETS**

<b>ST PAN 1/3</b>	Third-Size Stainless Steel Pan – 324 W x 175 D x 64 H mm	<b>\$50</b>
<b>ST PAN 1/2</b>	Half-Size Stainless Steel Pan – 324 W x 264 D x 64 H mm	<b>56</b>
<b>ST PAN 2</b>	Full-Size Stainless Steel Pan – 324 W x 527 D x 64 H mm	<b>68</b>
<b>ST PAN 4</b>	Full-Size Stainless Steel Pan – 324 W x 527 D x 102 H mm	<b>86</b>
<b>HDW 6" PAN</b>	Full-Size Stainless Steel Pan – 324 W x 527 D x 152 H mm	<b>94</b>
<b>Wire Trivets Stainless –</b>		
<b>TRIVET (1/2)SS</b>	Half-Size – 259 W x 194 D mm	<b>\$ 94</b>
<b>TRIVET SS</b>	Full-Size – 259 W x 457 D mm	<b>128</b>

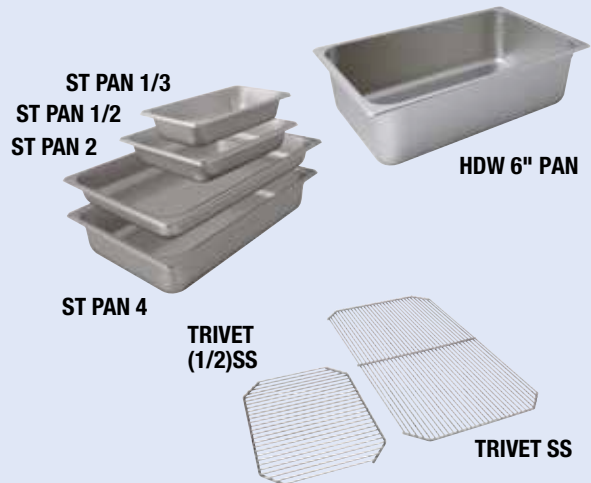

**SUPPORT BARS – FALSE BOTTOMS**

<b>CWB12BAR</b>	305 mm Pan Support Bar for Drop-In Ice or Refrigerated Wells	<b>\$16</b>
<b>CWB20BAR</b>	508 mm Pan Support Bar for Drop-In Ice or Refrigerated Wells	<b>19</b>
<b>False Bottom for Drop-In Refrigerated Wells (Perforated False Bottom Accessory, choose your appropriate pan size) –</b>		
<b>CWB-1FB</b>	For CWB-1 (1-Part Accessory)	<b>\$ 75</b>
<b>CWB-2FB</b>	For CWB-2 (1-Part Accessory)	<b>138</b>
<b>CWB-3FB</b>	For CWB-3 (2-Part Accessory)	<b>201</b>
<b>CWB-4FB</b>	For CWB-4 (2-Part Accessory)	<b>264</b>
<b>CWB-5FB</b>	For CWB-5 (3-Part Accessory)	<b>327</b>
<b>CWB-6FB</b>	For CWB-6 (3-Part Accessory)	<b>390</b>
<b>False Bottom for Slim Refrigerated Wells (choose your appropriate pan size) –</b>		
<b>1FBS8</b>	For CWB-S1 (1-Part Accessory)	<b>\$ 75</b>
<b>2FBS8</b>	For CWB-S2 (1-Part Accessory)	<b>138</b>
<b>3FBS8</b>	For CWB-S3 (2-Part Accessory)	<b>201</b>
<b>4FBS8</b>	For CWB-S4 (2-Part Accessory)	<b>264</b>

**Support Bars**  
Choose the appropriate kit for IWB or CWB series

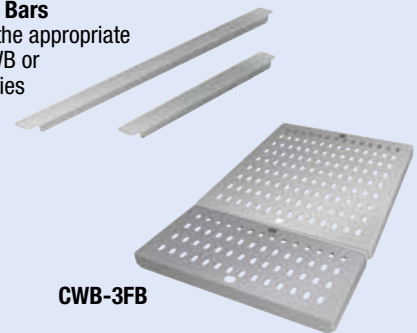

**False Bottom Accessories**  
1-part, 2- or 3-part(s) depending on pan size

**(CWB-1, -2, -3, -4, -5 or -6FB)**  
for the CWB series

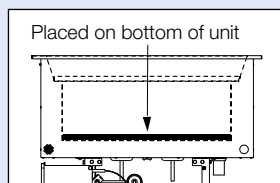

**(1, 2, 3, or 4FBS8)**  
for the CWB-S series

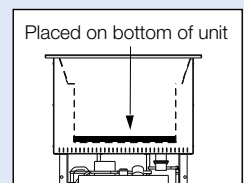

## Drop-In Frost Top and Drop-In Slim Frost Top Ordering Instructions

Cutaway of **FTB-3** with accessory sheet pans

**NSF 7 Component** approved, keeps food product cold without drying it out



**Please specify the following with each order:**

1. **Desired Voltage:**  
220-240V
2. **Number of Full-Size Sheet Pans Accommodated:**  
1-, 2- or 3-pan as rectangular sheet pans
3. **Depth of Model:** Standard configuration (735 mm D) or Slim configuration (535 mm D)
4. **Drain – 1" NPT Drain** for FTB-2, FTB-3 FTB-S2, FTB-S3 only (drain plumbing to be installed per local codes)
5. **Agency – NSF 7 Component**
6. **Electronic Control Assembly** can be mounted on either side of the Condensing Unit or remotely mounted up to 1219 mm from the unit (cannot be mounted over the Condensing Unit)

**Accessories**

1. **Pans –**
  - A. Half-size sheet pan  
457 W x 330 D mm
  - B. Full-size sheet pan  
457 W x 660 D mm



**DROP-IN FROST TOP AND SLIM DROP IN FROST TOP COUNTERTOP CUT-OUTS**

Model	Minimum Width	Maximum Width	Minimum Depth	Maximum Depth
<b>FTB-1</b>	494 mm	511 mm	697 mm	711 mm
<b>FTB-2</b>	949 mm	965 mm	694 mm	711 mm
<b>FTB-3</b>	1407 mm	1422 mm	694 mm	711 mm
<b>FTB-S2</b>	1354 mm	1372 mm	494 mm	511 mm
<b>FTB-S3</b>	2011 mm	2029 mm	494 mm	511 mm



## Drop-In Frost Tops and Drop-In Slim Frost Tops

Convenience meets style with the Hatco Drop-In Frost Tops. Perfect for quick turn products on self-serve buffets. Ideal for snacks, hors d'oeuvres, side dishes, desserts... truly a unit for breakfast, lunch and dinner. Sturdy construction and easy clean-up while keeping things cool. Also available in a Slim configuration, providing wider access to your customer.

- Accommodates full-size sheet pans
- Units include a 1" NPT brass drain (excluding FTB-1) and refrigeration system
- Electronic adjustable temperature control can be mounted to either side of the condensing unit or remotely up to 1219 mm from unit
- The condensing unit, mounted on the center of the unit, rotates 90° or 180°
- Mobile condensing unit may be moved in 165 mm increments from end to center in the FTB-3 units, and in 76 mm increments from end to center in the FTB-2
- Optimal insulation on sides and bottom to ensure better cold retention, and built with one of the most efficient condensing units on the market
- Auto-defrost is activated through an advanced electronic controller programmed at the customer location

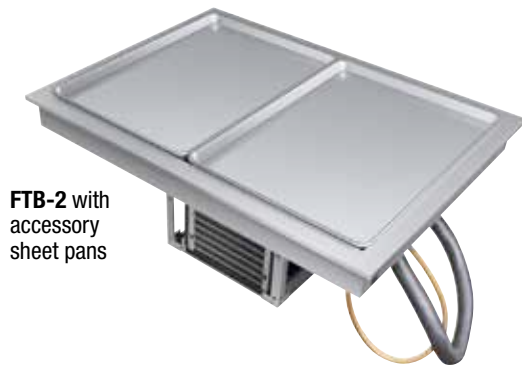

FTB-2 with accessory sheet pans



FTB-S2 with accessory sheet pans

### DROP-IN FROST TOPS AND DROP-IN SLIM FROST TOPS

Model	Dimensions (W x D x H)	List Price
FTB-1	535 x 735 x 437 mm	\$5790
FTB-2	991 x 735 x 437 mm	6413
FTB-3	1448 x 735 x 437 mm	7115
<b>Slim</b>		
FTB-S2	1395 x 535 x 437 mm	\$6476
FTB-S3	2053 x 535 x 437 mm	7225

CE Mark not available.

#### All Drop-In Frost Top Models Feature:

**Voltage:** 220-240V, single phase.

**Models Shipped with:** Electronic temperature control, condensing unit, compressor and flexible refrigerant lines to bottom of unit.

**Consult Factory for:** HP, watts, shipping and refrigerant specifications.

### ACCESSORIES (available for purchase at any time)

ALUM PAN	Half-Size Sheet Pan – 457 W x 330 D mm	\$28
18" SHEET PAN	Full-Size Sheet Pan – 457 W x 660 D mm	39

### COUNTERTOP CUT-OUT DIMENSIONS – PAGE 13

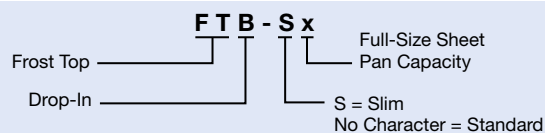



## Remote Drop-In Frost Top Ordering Instructions

Cutaway of **FTBX-3**  
with accessory sheet pans

**Frost Top with:**  
Temperature  
Probe

1" NPT brass drain  
simplifies cleaning and  
flat drain strainer ensures  
pans sit flush

Recessed walls designed to  
prevent food pan slippage

Control Panel



Auto-defrost activated  
through an advanced  
electronic controller  
programmed at the  
customer location

Environmentally-  
friendly insulation  
used throughout

**NSF 7 Component** approved, keeps food  
product cold without drying it out

**Please specify the following with each order:**

1. **Desired Voltage:**  
220 or 240V
2. **Number of Full-Size Sheet Pans Accommodated:**  
1-, 2- or 3-pan as rectangular sheet pans
3. **Depth of Model:** Standard configuration (735 mm D)  
or Slim configuration (535 mm D)
4. **Remote Refrigeration**  
**Note:** Shipped loose: Frost Top, Control Panel  
(Probe Wires are 4.9 meters) and a TXV Valve  
A. FTBX, without a Condensing Unit  
(Solenoid Valve attached to Frost Top)
5. **Agency** – NSF 7 Component

### Accessories

1. **Pans** –
  - A. Half-size sheet pan  
457 W x 330 D mm
  - B. Full-size sheet pan  
457 W x 660 D mm



### REMOTE DROP-IN FROST TOP COUNTERTOP CUT-OUTS

Model	Minimum Width	Maximum Width	Minimum Depth	Maximum Depth
FTBX-1	697 mm	711 mm	494 mm	511 mm
FTBX-2	949 mm	965 mm	694 mm	711 mm
FTBX-3	1407 mm	1422 mm	694 mm	711 mm
FTBX-S2	1354 mm	1372 mm	494 mm	511 mm
FTBX-S3	2011 mm	2029 mm	494 mm	511 mm



## Remote Drop-In Frost Tops

Keeping pre-chilled beverages, snacks, hors d'oeuvres and side dishes cool and ready-to-serve, the Hatco Remote Drop-In Frost Tops offer additional flexibility with remote configurations. Also available in a Slim configuration, providing wider access to your customer.

- Accommodates full-size sheet pans
- Units include a 1" NPT brass drain (excluding FTBR-1 and FTBX-1) and refrigeration system
- FTBR models include a condensing unit (shipped loose, can be field mounted up to 15 meters of tubing from unit) and a control panel (shipped loose - probe wires are 4.88 meters) for installing in more convenient or desirable locations
- FTBX models include a control panel (shipped loose - probe wires are 4.88 meters) but shipped without a condensing unit for the increased flexibility of multiple Frost Top configurations
- Easy serviceability with a sight glass, service valves, dryer and a receiver (FTBR models only)
- Auto-defrost is activated through an advanced electronic controller programmed at the customer location (FTBR models only)
- Optimal insulation on sides and bottom to ensure better cold retention, and built with one of the most efficient condensing units on the market

**FTBR-S2**  
with accessory  
sheet pans



**Frost Top**  
with a  
temperature  
probe,  
control panel and  
a condensing unit  
(both shipped loose)

**FTBX-S2** with accessory  
sheet pans (shipped  
without condensing unit)



Control panel  
(shipped loose)

### REMOTE DROP-IN FROST TOPS – WITH CONDENSING UNIT AND CONTROL PANEL

Model	Dimensions W x D x H	List Price
FTBR-1	735 x 535 x 90 mm	\$4941
FTBR-2	991 x 735 x 90 mm	5559
FTBR-3	1448 x 735 x 90 mm	6257

**Slim**

FTBR-S2	1395 x 535 x 90 mm	\$5622
FTBR-S3	2053 x 535 x 90 mm	6366

CE Mark not available.

**All Remote Drop-In Frost Top Models Feature:**

**Voltage:** 220-240V, single phase.

**Models Shipped with:** Electronic temperature control, condensing unit and TXV valve (all shipped loose).

**Consult Factory for:** HP and refrigerant specifications.

### REMOTE DROP-IN FROST TOPS – WITH CONTROL PANEL

Model	Dimensions W x D x H	List Price
FTBX-1	735 x 535 x 218 mm	\$3962
FTBX-2	991 x 735 x 218 mm	4592
FTBX-3	1448 x 735 x 218 mm	5291
<b>Slim</b>		
FTBX-S2	1395 x 535 x 218 mm	\$4655
FTBX-S3	2053 x 535 x 218 mm	5400

CE Mark not available.

**All Remote Drop-In Frost Top Models Feature:**

**Voltage:** 220-240V, single phase.

**Consult Factory for:** HP and refrigerant specifications.

**Models Shipped with:** Electronic temperature control, TXV valve (shipped loose) and a solenoid valve attached to well.

**Consult Factory for:** HP and refrigerant specifications.

### ACCESSORIES (available for purchase at any time)

ALUM PAN	Half-Size Sheet Pan – 457 W x 330 D mm	\$28
18" SHEET PAN	Full-Size Sheet Pan – 457 W x 660 D mm	39

### COUNTERTOP CUT-OUT DIMENSIONS – PAGE 15

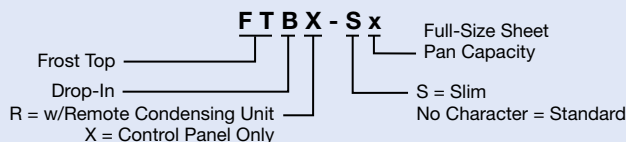

## Modular/Ganged Heated Wells Ordering Instructions

Cutaway of **HWBI-5MA** with accessory food pans and optional split control boxes

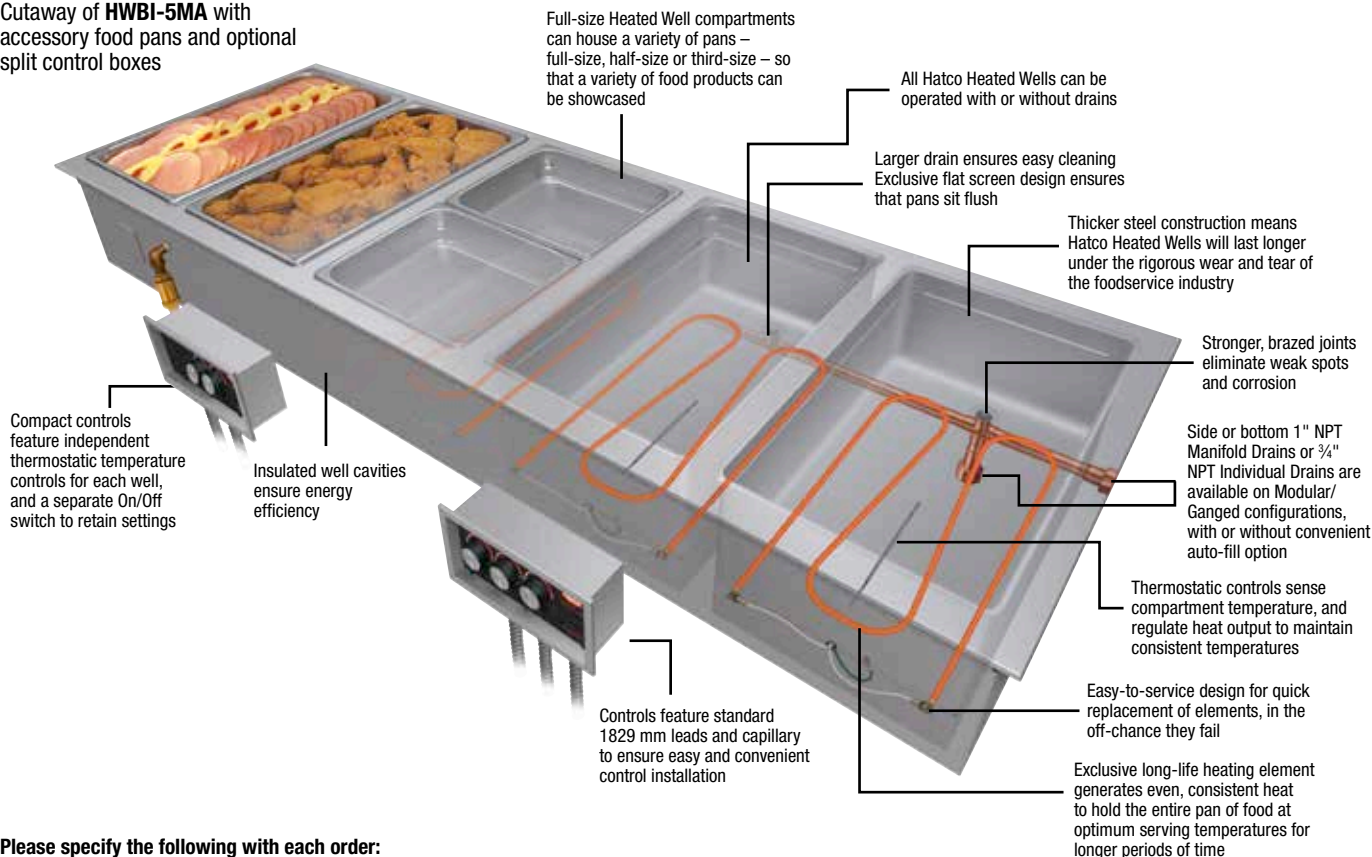

Please specify the following with each order:

**1. Desired Voltage:**

- HWBI-1DA: 220 or 240V, single phase
- HWBI-2, -3, -4, -5, -6 Series (D, DA, M, MA): 220 or 240V, single or optional three phase
- HWBLI-1DA, -2, -3, -4, -5, -6 Series (D, DA, M, MA): 220-240V single phase
- HWBI43-1 (D, DA)
- HWBI43-2, -3, -4, -5, -6 Series (D, DA, M, MA): 220 or 240V, single phase

**2. Number of Modular/Ganged Heated Wells Required:**

- 1-, 2-, 3-, 4-, 5- or 6-pan
- NOTE:** Modular/Ganged units are only offered as rectangular, full-size (305 x 508 mm) or as 4/3-size wells (12" x 27")

**3. Drain (with or without – choose drain below):**

- A. Standard Individual Well 3/4" NPT Drain
- B. Manifold 1" NPT Drain with side drain, field selectable left or right side (available on HWBI- or HWBLI-2, -3, -4, -5, -6 models only)

- C. Manifold 1" NPT Drain with bottom drain, field selectable left or right well (available on HWBI- or HWBLI-2, -3, -4, -5, -6 models only)

**4. Auto-fill (with or without)**

- 5. Bezel** allows a 686 mm depth for modular units to match Hatco CWB models in a countertop display (not available for HWBI43 Series)

**6. Agency:**

- A. CE Mark available on standard watt models

**7. Control:**

- A. Single Control Box (standard on all units)
- B. Split Control Boxes (optional on 4-, 5-, 6-pan units, not available on 1-, 2-, 3-pan units)

**Accessories for Modular/Ganged Heated Wells**

- 1. Pan Support Bars:** 305 or 508 mm
- 2. Adapters** to convert Modular/Ganged units to hold 4- or 7-liter round pans
- 3. Stainless Steel Pans:**
  - A. Third-size at 64 mm deep (324 W x 175 D x 64 H mm)
  - B. Half-size at 64 mm deep (324 W x 264 D x 64 H mm)
  - C. Full-size at 64 mm deep (324 W x 527 D x 64 H mm)
  - D. Full-size at 102 mm deep (324 W x 527 D x 102 H mm)
  - E. Full-size at 152 mm deep (324 W x 527 D x 152 H mm)
- 4. Valves:**
  - A. 3/4" or 1" NPT Ball Valve
  - B. 3/4" or 1" NPT Gate Valve

**ACCESSORIES – PAGE 34-35**

**DROP-IN MODULAR/GANGED HEATED WELLS COUNTERTOP CUTOUTS**

Model	Minimum Width	Maximum Width	Minimum Depth	Maximum Depth
<b>HWBI-1 Series</b>	359 mm	368 mm	565 mm	575 mm
<b>HWBI-2 Series</b>	715 mm	724 mm	565 mm	575 mm
<b>HWBI-3 Series</b>	1070 mm	1080 mm	565 mm	575 mm
<b>HWBI-4 Series</b>	1426 mm	1435 mm	565 mm	575 mm
<b>HWBI-5 Series</b>	1781 mm	1791 mm	565 mm	575 mm
<b>HWBI-6 Series</b>	2137 mm	2146 mm	565 mm	575 mm
<b>4/3-Size</b>				
<b>HWBI43-1 Series</b>	361 mm	367 mm	742 mm	748 mm
<b>HWBI43-2 Series</b>	716 mm	721 mm	742 mm	748 mm
<b>HWBI43-3 Series</b>	1072 mm	1076 mm	742 mm	748 mm
<b>HWBI43-4 Series</b>	1428 mm	1432 mm	742 mm	748 mm
<b>HWBI43-5 Series</b>	1783 mm	1788 mm	742 mm	748 mm
<b>HWBI43-6 Series</b>	2139 mm	2143 mm	742 mm	748 mm



From the top, the modular design allows the Modular/Ganged Heated Well to appear as one integrated unit. From below, you will see separate covers, with easy, independent access to each one. This makes installation and service easy





## Modular/Ganged Heated Wells

Hatco Modular/Ganged Heated Wells are full-size units that are grouped together in a modular fashion to provide customers with a complete steam table contained within one piece of equipment for a clean, integrated look. Select the configuration that's right for your foodservice operation.

- Full-size, insulated Wells available in 1- to 6-Modular/Ganged units
- Individual thermostatic controls for each well provide the ultimate in temperature regulation
- 1829 mm conduit is standard for convenient placement of controls
- Wells empty quickly and easily with a manifold drain option

- Auto-fill option to automatically fill and replenish water without user maintenance and intervention
- Separate well assemblies with independent access to each one for easy service



HWBI-5MA with standard single control box with accessory food pans

### STANDARD WATT DROP-IN MODULAR/GANGED SIZE RECTANGULAR MODELS – INSULATED – TOP MOUNT

Model	Dimensions, W x D x H	Voltage	Watts	Ship Weight	List Price
HWBI-1	394 x 600 x 243 mm	220 or 240 <sup>†</sup>	1215	15 kg	\$ 1009
HWBI-1D	394 x 600 x 243 mm	220 or 240 <sup>†</sup>	1215	17 kg	1087
HWBI-1DA	394 x 600 x 243 mm	220 or 240 <sup>†</sup>	1215	17 kg	1536
HWBI-2	749 x 600 x 243 mm	220 or 240 <sup>†</sup>	2415	33 kg	2195
HWBI-2D	749 x 600 x 243 mm	220 or 240 <sup>†</sup>	2415	35 kg	2309
HWBI-2DA*	749 x 600 x 243 mm	220 or 240 <sup>†</sup>	2415	40 kg	2759
HWBI-2M	749 x 600 x 243 mm	220 or 240 <sup>†</sup>	2415	34 kg	2361
HWBI-2MA	749 x 600 x 243 mm	220 or 240 <sup>†</sup>	2415	39 kg	2962
HWBI-3	1105 x 600 x 243 mm	220 or 240 <sup>†</sup>	3615	47 kg	2739
HWBI-3D	1105 x 600 x 243 mm	220 or 240 <sup>†</sup>	3615	45 kg	2944
HWBI-3DA*	1105 x 600 x 243 mm	220 or 240 <sup>†</sup>	3615	51 kg	3393
HWBI-3M	1105 x 600 x 243 mm	220 or 240 <sup>†</sup>	3615	49 kg	3129
HWBI-3MA	1105 x 600 x 243 mm	220 or 240 <sup>†</sup>	3615	51 kg	3731
HWBI-4	1461 x 600 x 243 mm	220 or 240 <sup>†</sup>	4815	60 kg	3551
HWBI-4D	1461 x 600 x 243 mm	220 or 240 <sup>†</sup>	4815	62 kg	3921
HWBI-4DA*	1461 x 600 x 243 mm	220 or 240 <sup>†</sup>	4815	60 kg	4370
HWBI-4M	1461 x 600 x 243 mm	220 or 240 <sup>†</sup>	4815	63 kg	4232
HWBI-4MA	1461 x 600 x 243 mm	220 or 240 <sup>†</sup>	4815	63 kg	4834
HWBI-5	1816 x 600 x 243 mm	220 or 240 <sup>†</sup>	6015	76 kg	4258
HWBI-5D	1816 x 600 x 243 mm	220 or 240 <sup>†</sup>	6015	75 kg	4881
HWBI-5DA*	1816 x 600 x 243 mm	220 or 240 <sup>†</sup>	6015	76 kg	5342
HWBI-5M	1816 x 600 x 243 mm	220 or 240 <sup>†</sup>	6015	76 kg	5290
HWBI-5MA	1816 x 600 x 243 mm	220 or 240 <sup>†</sup>	6015	75 kg	5875
HWBI-6	2172 x 600 x 243 mm	220 or 240 <sup>†</sup>	7215	86 kg	5517
HWBI-6D	2172 x 600 x 243 mm	220 or 240 <sup>†</sup>	7215	86 kg	6017
HWBI-6DA*	2172 x 600 x 243 mm	220 or 240 <sup>†</sup>	7215	88 kg	6446
HWBI-6M	2172 x 600 x 243 mm	220 or 240 <sup>†</sup>	7215	86 kg	6576
HWBI-6MA	2172 x 600 x 243 mm	220 or 240 <sup>†</sup>	7215	89 kg	7147

<sup>†</sup> 220V or 240V CE Mark available at no added charge.

\* Auto-fill located on left control only and fills left-hand well. To fill all wells, drains must be connected with external manifold by installer.

All Standard Watt Drop-In Modular/Ganged Full-Size Rectangular Heated Well Models Feature:

Voltage: Single phase.

Models Shipped with: EZ locking hardware for installation and remote thermostats with flexible conduits and lighted power switches.

### OPTIONS (available at time of purchase only)

HWBI-SIDE	Copper Manifold drain with side exit (not available on HWBI-1)	No Charge
HWBI-BOTTOM	Copper Manifold drain with bottom exit (not available on HWBI-1)	No Charge
OS-BEZEL27	686 mm deep Bezel for Modular unit to match Hatco CWB in a countertop display	No Charge
COND-3	914 mm Flexible Conduit (1829 mm standard) available on split control only	No Charge

### Modular/Ganged Heated Wells Controls\*

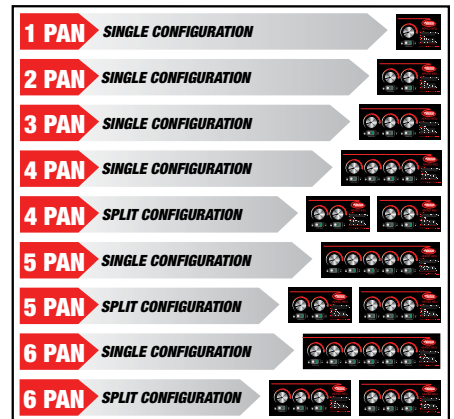

\*4-, 5-, 6-pan units: Single control box is standard. If optional split control boxes are desired, it must be specified at order.

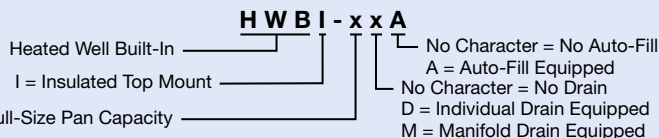

COUNTERTOP CUTOUT DIMENSIONS – PAGE 17  
ACCESSORIES – PAGE 34-35

## Drop-In Modular/ Ganged 4/3-Size Heated Wells

Hatco Modular/Ganged 4/3-Size Heated Wells maintain hot food at safe-serving temperatures, with better quality construction, longer holding times and more accurate temperatures. A deeper single unit can hold the equivalent of 4 third-size pans.

Choose the number of wells, from 1 to 6 unit configurations, as well as voltage, auto-fill, controls and drain options. Each well has its own individual control to regulate the temperature of each food offering.

- Longer holding times with more accurate temperatures
- Separate lighted On/Off rocker switch and temperature dial for easy operation

- 50% larger drain with flat screen simplifies cleaning and holds pans level
- Unique design allows quick change of element or thermostat if needed
- EZ locking hardware for quick installation
- Stainless steel construction and solid brazed drain fitting joints for durability
- A 1829 mm conduit is included for convenient placement of controls

### DROP-IN MODULAR/GANGED 4/3-SIZE RECTANGULAR MODELS – INSULATED – TOP MOUNT

Model	Dimensions W x D x H	Voltage	Watts	Ship Weight	List Price
HWBI43-1	394 x 772 x 244 mm	220 or 240 <sup>†</sup>	1215	19 kg	\$1464
HWBI43-1D	394 x 772 x 244 mm	220 or 240 <sup>†</sup>	1215	19 kg	1507
HWBI43-1DA	394 x 772 x 244 mm	220 or 240 <sup>†</sup>	1215	19 kg	2048
HWBI43-2	749 x 772 x 244 mm	220 or 240 <sup>†</sup>	2415	37 kg	2442
HWBI43-2D	749 x 772 x 244 mm	220 or 240 <sup>†</sup>	2415	39 kg	2532
HWBI43-2DA*	749 x 772 x 244 mm	220 or 240 <sup>†</sup>	2415	43 kg	3094
HWBI43-2M	749 x 772 x 244 mm	220 or 240 <sup>†</sup>	2415	37 kg	2776
HWBI43-2MA	749 x 772 x 244 mm	220 or 240 <sup>†</sup>	2415	42 kg	3339
HWBI43-3	1105 x 772 x 244 mm	220 or 240 <sup>†</sup>	3615	52 kg	3333
HWBI43-3D	1105 x 772 x 244 mm	220 or 240 <sup>†</sup>	3615	51 kg	3466
HWBI43-3DA*	1105 x 772 x 244 mm	220 or 240 <sup>†</sup>	3615	56 kg	4012
HWBI43-3M	1105 x 772 x 244 mm	220 or 240 <sup>†</sup>	3615	54 kg.	3747
HWBI43-3MA	1105 x 772 x 244 mm	220 or 240 <sup>†</sup>	3615	56 kg	4295
HWBI43-4	1461 x 772 x 244 mm	220 or 240 <sup>†</sup>	4815	67 kg	4392
HWBI43-4D	1461 x 772 x 244 mm	220 or 240 <sup>†</sup>	4815	69 kg	4567
HWBI43-4DA*	1461 x 772 x 244 mm	220 or 240 <sup>†</sup>	4815	68 kg	5114
HWBI43-4M	1461 x 772 x 244 mm	220 or 240 <sup>†</sup>	4815	70 kg	4885
HWBI43-4MA	1461 x 772 x 244 mm	220 or 240 <sup>†</sup>	4815	70 kg	5432
HWBI43-5	1816 x 772 x 244 mm	220 or 240 <sup>†</sup>	6015	85 kg	5351
HWBI43-5D	1816 x 772 x 244 mm	220 or 240 <sup>†</sup>	6015	84 kg	5578
HWBI43-5DA*	1816 x 772 x 244 mm	220 or 240 <sup>†</sup>	6015	85 kg	6141
HWBI43-5M	1816 x 772 x 244 mm	220 or 240 <sup>†</sup>	6015	84 kg	5941
HWBI43-5MA	1816 x 772 x 244 mm	220 or 240 <sup>†</sup>	6015	84 kg	6503
HWBI43-6	2172 x 772 x 244 mm	220 or 240 <sup>†</sup>	7215	97 kg	6395
HWBI43-6D	2172 x 772 x 244 mm	220 or 240 <sup>†</sup>	7215	97 kg	6681
HWBI43-6DA*	2172 x 772 x 244 mm	220 or 240 <sup>†</sup>	7215	98 kg	7270
HWBI43-6M	2172 x 772 x 244 mm	220 or 240 <sup>†</sup>	7215	97 kg	7153
HWBI43-6MA	2172 x 772 x 244 mm	220 or 240 <sup>†</sup>	7215	100 kg	7737

<sup>†</sup> 220V or 240V CE Mark available at no added charge.

\* Auto-fill located on left control only and fills left-hand well. To fill all wells, drains must be connected with external manifold by installer.

All Drop-In Modular/Ganged 4/3-Size Rectangular Heated Well Models Feature:

Voltage: Single phase.

Models Shipped with: EZ locking hardware for installation and remote thermostats with flexible conduits and lighted power switches.

### OPTIONS (available at time of purchase only)

HWBI-SIDE	Copper Manifold Drain with side exit (not available on HWBI43-1)	No Charge
HWBI-BOTTOM	Copper Manifold Drain with bottom exit (not available on HWBI43-1)	No Charge
COND-3	914 mm Flexible Conduit (1829 mm standard) available on split control only	No Charge

### HWBI43 - x x A

Heated Well Built-In	_____	No Character = No Auto-Fill
I = Insulated Top Mount	_____	A = Auto-Fill Equipped
43=4/3-Size Depth	_____	No Character = No Drain
No Character=Full-Size Depth only	_____	D = Individual Drain Equipped
		M = Manifold Drain Equipped
		Full-Size Pan Capacity



**HWBI43-3DA with**  
 - 4 third-size pans,  
 - 2 half-size pans and one third-size pan  
 - 1 full-size pan and 1 third-size pan



### Modular/Ganged Heated Wells Controls\*

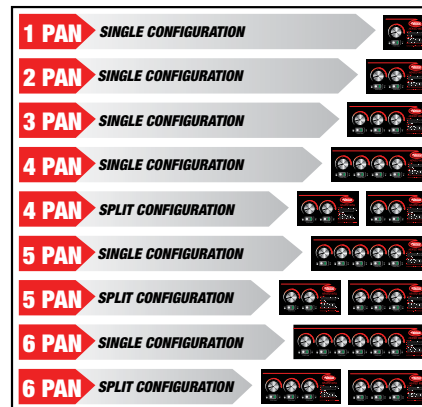

\*4-, 5-, 6-pan units: Single control box is standard. If optional split control boxes are desired, it must be specified at order.

ACCESSORIES – PAGE 34-35



## Modular/Ganged Slim Heated Wells Ordering Instructions

Cutaway of **HWBI-S4MA** with accessory food pans and standard single control box

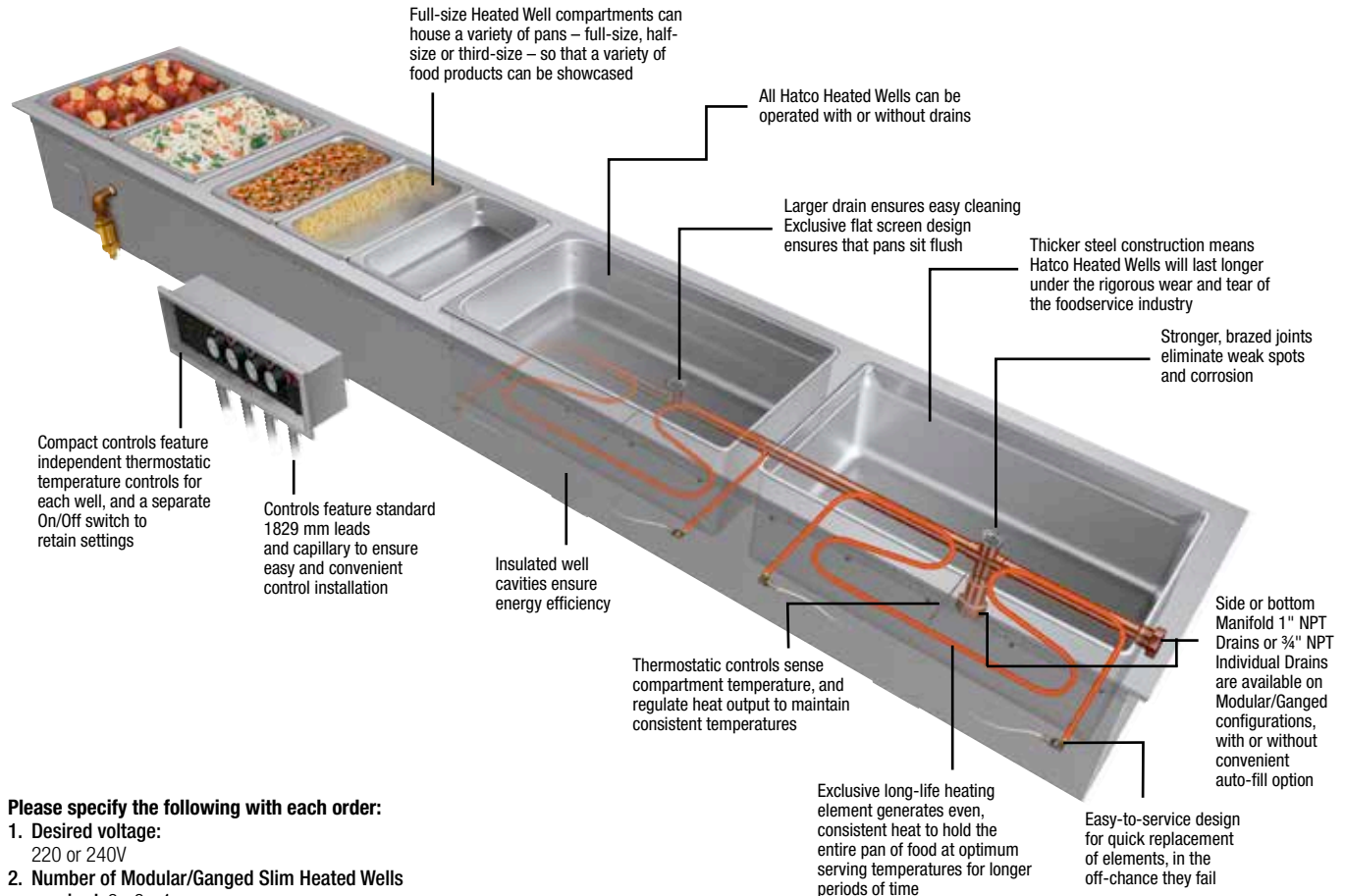

### Please specify the following with each order:

- Desired voltage:**  
220 or 240V
- Number of Modular/Ganged Slim Heated Wells required:** 2-, 3-, 4-pan  
NOTE: Modular/Ganged Slim units are only offered as rectangular full-size (305 x 508 mm) but placed lengthwise
- Drain** (with or without):  
A. Standard Individual Well 3/4" NPT Drain  
B. Manifold 1" NPT Drain with side drain, field selectable left or right side  
C. Manifold 1" NPT Drain with bottom drain, field selectable left or right well
- Auto-fill** (with or without)
- Bezel** allows a 481 mm D for modular units to match Hatco Refrigerated Slim Drop-In models in a countertop display
- Agency:**  
A. CE Mark available
- Control:**  
A. Single Controls (standard on all units)  
B. Split Controls (optional on 4-pan units)

### Accessories for Modular/Ganged Slim Heated Wells

- Pan Support Bars:**  
305 or 508 mm
- Adapters** to convert Modular/Ganged Slim units to hold 4- or 7-liter round pans
- Stainless Steel Pans:**  
A. Third-size at 64 mm deep (324 W x 175 D x 64 H mm)  
B. Half-size at 64 mm deep (324 W x 264 D x 64 H mm)  
C. Full-size at 64 mm deep (324 W x 527 D x 64 H mm)  
D. Full-size at 102 mm deep (324 W x 527 D x 102 H mm)  
E. Full-size at 152 mm deep (324 W x 527 D x 152 H mm)
- Valves:**  
A. 3/4" or 1" NPT Ball Valve  
B. 3/4" or 1" NPT Gate Valve

**ACCESSORIES – PAGE 34-35**

### DROP-IN MODULAR/GANGED SLIM HEATED WELLS COUNTERTOP CUTOUTS

Model	Minimum Width	Maximum Width	Minimum Depth	Maximum Depth
HWBI-S2	1121 mm	1127 mm	362 mm	368 mm
HWBI-S3	1680 mm	1686 mm	362 mm	368 mm
HWBI-S4	2238 mm	2245 mm	362 mm	368 mm



## Modular/Ganged Slim Heated Wells

Hatco Modular/Ganged Slim Heated Wells are full-sized units that are grouped together in a modular fashion but placed lengthwise. This provides customers with a complete steam table within easy reach, regardless of the sneeze guards. Select the configuration that's right for your foodservice operation.

- Full-size, insulated wells available in 2- to 4-ganged units
- Individual thermostatic controls for each well provide the ultimate in temperature regulation
- 1829 mm conduit is standard for convenient placement of controls
- Wells empty quickly and easily with a manifold drain option
- Auto-fill option to automatically fill and replenish water without user maintenance and intervention
- Separate well assemblies with independent access to each one for easy service



HWBI-S4MA with accessory food pans and optional split control boxes

### DROP-IN MODULAR/GANGED SLIM RECTANGULAR MODELS – INSULATED – TOP MOUNT

Model*	Dimensions W x D x H	Voltage	Watts	Ship Weight	List Price
HWBI-S2	1156 x 397 x 238 mm	220 or 240 <sup>†</sup>	2415	38 kg	\$2376
HWBI-S2D	1156 x 397 x 238 mm	220 or 240 <sup>†</sup>	2415	37 kg	2483
HWBI-S2DA*	1156 x 397 x 238 mm	220 or 240 <sup>†</sup>	2415	38 kg	2934
HWBI-S2M	1156 x 397 x 238 mm	220 or 240 <sup>†</sup>	2415	39 kg	2573
HWBI-S2MA	1156 x 397 x 238 mm	220 or 240 <sup>†</sup>	2415	41 kg	3172
HWBI-S3	1715 x 397 x 238 mm	220 or 240 <sup>†</sup>	3615	54 kg	2999
HWBI-S3D	1715 x 397 x 238 mm	220 or 240 <sup>†</sup>	3615	52 kg	3217
HWBI-S3DA*	1715 x 397 x 238 mm	220 or 240 <sup>†</sup>	3615	57 kg	3657
HWBI-S3M	1715 x 397 x 238 mm	220 or 240 <sup>†</sup>	3615	57 kg	3420
HWBI-S3MA	1715 x 397 x 238 mm	220 or 240 <sup>†</sup>	3615	57 kg	4020
HWBI-S4	2273 x 397 x 238 mm	220 or 240 <sup>†</sup>	4815	70 kg	3972
HWBI-S4D	2273 x 397 x 238 mm	220 or 240 <sup>†</sup>	4815	70 kg	4307
HWBI-S4DA*	2273 x 397 x 238 mm	220 or 240 <sup>†</sup>	4815	73 kg	4744
HWBI-S4M	2273 x 397 x 238 mm	220 or 240 <sup>†</sup>	4815	70 kg	4632
HWBI-S4MA	2273 x 397 x 238 mm	220 or 240 <sup>†</sup>	4815	69 kg	5217

<sup>†</sup> 220V or 240V CE Mark available at no added charge.

\* Auto-fill located on left control only and fills left-hand well. To fill all wells, drains must be connected with external manifold by installer.

#### All Drop-In Modular/Ganged Slim Rectangular Heated Well Models Feature:

Voltage: Single phase.

Models Shipped with: EZ locking hardware for installation and remote thermostats with lighted power switches.

#### OPTIONS (available at time of purchase only)

HWBI-SIDE	Copper Manifold Drain with side exit	No Charge
HWBI-BOTTOM	Copper Manifold Drain with bottom exit	No Charge
OS-BEZEL19	483 mm D Bezel for Modular unit to match Hatco CWB Slim models in a countertop display	No Charge

#### Modular/Ganged Slim Heated Wells Controls\*

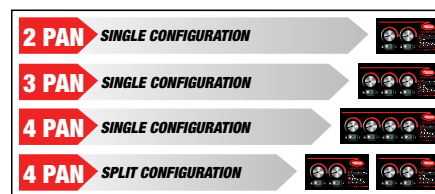

\*4-Pan Units: Single control box is standard. If optional split control boxes are desired, it must be specified at order.

#### COUNTERTOP CUTOUT DIMENSIONS – PAGE 20 ACCESSORIES – PAGE 34-35

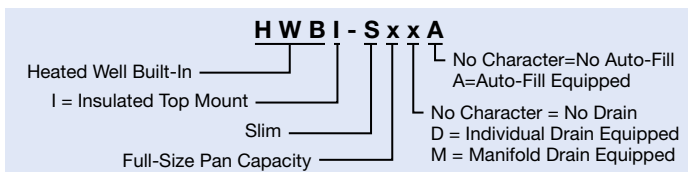



# Individual Built-In And Drop-In Heated Wells Ordering Instructions

Please specify the following with each order:

1. **Desired Voltage:** 220 or 240V
2. **Base Size of Heated Well:**
  - A. Rectangular:
    - Full (305 x 508 mm) or 4/3 (305 x 686 mm)
  - B. Round: 4-liter, 7-liter or 10-liter
3. **Drain** (with or without)
4. **Auto-fill** (with or without)
5. **Insulated or Uninsulated**



**Insulated Well Construction**  
Full-size models are available with insulation for energy saving

6. **Corners**
  - A. Standard (Rounded)
  - B. Square Corners
7. **Mounting Style:**
  - A. Top Mounted
  - B. Bottom Mounted (rectangular full-size units only)
8. **Wattage:**
  - A. High watt
  - B. Standard watt
9. **Agency:**
  - A. CE Mark available (fabricator models are not a CE offering, items are sold as components for fabricator self certification)



Top Mounted Heated Well: Unit is mounted through the top surface of a sheet metal counter and secured with turn tabs (unit and food pan edge visible)



Bottom Mounted Heated Well: Full-size (only) unit is mounted to the bottom surface of a sheet metal counter and secured with customer provided turned bends and fasteners (food pan edge visible)

**CONTROL BOXES, COUNTERTOP CUT-OUT DIMENSIONS – PAGE 23**



**HWB-43D** with accessory food pans (single unit holding 4 third-size pans – unit depth is 726 mm)



Easy to access the heating elements, if it ever becomes necessary to change them



**H W B x x x x - x D A**

- Heated Well Built-In
- No Character = Standard Watt
- H = High Watt
- No Character = Uninsulated
- I = Insulated Top Mount
- IB=Insulated Bottom Mount
- RT = Thermostatic Control (Fabricator Only)
- RN = Infinite Switch Control (Fabricator Only)
- No Character = No Auto-Fill
- A = Auto-Fill Equipped
- No Character = No Drain
- D = Drain Equipped
- FUL = Full-Size Pan
- 43 = 4/3-Size Pan
- 4QT = Round 4-Liter Pan
- 7QT = Round 7-Liter Pan
- 11QT = Round 10-Liter Pan
- No Character = Standard Corners
- Q = Square Corners

## Individual Built-In And Drop-In Heated Wells Ordering Instructions

### Options for Individual Built-In and Drop-In Heated Wells

#### 1. Control Box:

- A. Larger (front mounted) Recessed Thermostatic Control Box with Lighted On/Off Rocker Switch and Angled Recessed Controls for easy readability (not for auto-fill)
- B. Optional ITC Control (not available for auto-fill, 4-liter Round Wells, Insulated Round Wells or units without a drain)
- C. Standard Control for auto-fill models only

#### STANDARD CONTROLS

Larger Recessed Thermostatic Control – No Charge



#### OPTIONAL CONTROLS

ITC Control (Not available for 4-liter Round Wells, Insulated Round Wells, units without a drain or auto-fill)



#### 2. Control Type:

- A. Thermostatic
  - A. Infinite
- NOTE:** Infinite controls are only available on fabricator units

#### 3. Leads:

Extended high temp lead wire, per 305 mm

#### 4. Thermostat with 1829 mm Capillary

(914 mm standard)

#### CONTROL TYPE – UR and C-UR Components



Thermostatic control



Infinite control

#### STANDARD CONTROL AUTO-FILL

HWB-43DA, HWBIB-, HWBI-FULDA, HWBI-7QTDA, -11QTDA Standard Control (only for auto-fill)



### Accessories for Individual Built-In and Drop-In Heated Wells

1. **Mounting Kits** for combustible countertops (individual drop-in top mount units only)
2. **Pan Support Bars:** 305 or 508 mm
3. **Adapters** to convert rectangular full-size units to hold 4- or 7-liter round pans, or 4/3-size units to hold 10-liter round pans
4. **Stainless Steel Pans:**
  - A. Third-size at 64 mm deep (324 W x 175 D x 64 H mm)
  - B. Half-size at 64 mm deep (324 W x 264 D x 64 H mm)
  - C. Full-size at 64 mm deep (324 W x 527 D x 64 H mm)
  - D. Full-size at 102 mm deep (324 W x 527 D x 102 H mm)
  - E. Full-size at 152 mm deep (324 W x 527 D x 152 H mm)

#### 5. Valve:

- A. 3/4" NPT Ball Valve for unit with Drain
- B. 3/4" NPT Gate Valve for unit with Drain

#### 6. Remote Handle for 3/4" Drains only and includes a Ball Valve

### ACCESSORIES – PAGE 34-35

#### CONTROL CUTOUT DIMENSIONS

##### Standard Larger Recessed Thermostatic Control:

149 W x 162 H mm

##### Optional ITC Control:

149 W x 162 H mm

##### HWB-43DA, HWBIB-, HWBI-FULDA

##### Standard Control for Auto-fill

257 W x 121 H mm



#### How to Order a Hatco Heated Well in Video

Hatco has given you a variety of simple and easy ways to order your well. You can read the Ordering Instructions here or watch a video "How to Order a Hatco Heated Well." Go to [hatcocorp.com](http://hatcocorp.com) and click on the Video Library. While you are here, watch the "Hatco Refrigerated Wells" video as well.

### COMBUSTIBLE COUNTERTOP CUTOUTS – BUILT-IN AND DROP-IN HEATED WELLS

Model	Minimum Width	Maximum Width	Minimum Depth	Maximum Depth
HWB-FUL, -FULD, FULDA, HWBQ-FUL, FULD, FULDA	356 mm	362 mm	559 mm	565 mm
HWBI-FUL, -FULD, FULDA, HWBIQ-FUL, -FULD, FULDA	356 mm	362 mm	559 mm	565 mm
HWB-, HWBI-43	356 mm	362 mm	737 mm	743 mm
HWB-, HWBI-4QT	229 mm	235 mm	229 mm	235 mm
HWB-, HWBI-7QT	279 mm	286 mm	279 mm	286 mm
HWB-, HWBI-11QT	330 mm	337 mm	330 mm	337 mm

### NONCOMBUSTIBLE COUNTERTOP CUTOUTS – BUILT-IN AND DROP-IN HEATED WELLS

Model	Minimum Width	Maximum Width	Minimum Depth	Maximum Depth
HWB-, HWBQ-FUL	321 mm	328 mm	524 mm	531 mm
HWB-, HWBQ-FULDA	321 mm	328 mm	524 mm	532 mm
HWBI-FUL, -FULD, HWBIQ-FUL, -FULD	324 mm	328 mm	528 mm	531 mm
HWBI-, HWBIQ-FULDA <sup>▼</sup>	324 mm	328 mm	530 mm	532 mm
HWBIB-, HWBIBQ-FUL <sup>▼</sup> , -FULDA <sup>▼</sup>	306 mm	306 mm	509 mm	509 mm
HWB-, HWBI-43	323 mm	328 mm	704 mm	711 mm
HWB-4QT,	181 mm Dia.	192 mm Dia.	—	—
HWB-7QT	232 mm Dia.	243 mm Dia.	—	—
HWB-11QT	282 mm Dia.	294 mm Dia.	—	—
HWBI-4QT,	187 mm Dia.	187 mm Dia.	—	—
HWBI-7QT	243 mm Dia.	243 mm Dia.	—	—
HWBI-11QT	289 mm Dia.	289 mm Dia.	—	—

<sup>▼</sup> Must be flanged.





## Built-In Full-Size Heated Wells

Hatco Built-In Heated Wells hold heated foods at safe-serving temperatures. Compared to other models, Hatco units offer larger drain with a flat drain screen, more consistent holding temperatures, heavier stainless steel construction, easier-to-service design for quick change of components and a remote thermostat with separate power switch.

- Rectangular full-size only in top or bottom mount, insulated or uninsulated
- Low (120V only), standard and high watt
- Available with or without a drain (easy to clean with a larger drain and a flat screen)
- Easy access design allows for quick element or thermostat change
- Accessory mounting kits for combustible countertops available
- Accessory adapters to convert full-size wells to hold round pans available

## Control Options

– See page 23

HWBIB-FULD with accessory food pan



HWBI-FULD with accessory food pan



HWB-FULD with accessory food pan

### BUILT-IN FULL-SIZE RECTANGULAR MODELS

Model	Description	Dimensions W x D x H	Voltage	Watts	Ship Weight	List Price
<b>Standard Watt</b>						
HWB-FUL	Uninsulated Top or Bottom Mount	347 x 553 x 207 mm	220 or 240 <sup>‡</sup>	1200	10 kg	<b>\$ 673</b>
HWB-FULD	Uninsulated Top or Bottom Mount w/Drain	347 x 553 x 207 mm	220 or 240 <sup>‡</sup>	1200	10 kg	<b>712</b>
HWB-FULDA	Uninsulated Top or Bottom Mount w/Drain, Auto-fill	347 x 553 x 207 mm	220 or 240 <sup>‡</sup>	1215	14 kg <sup>†</sup>	<b>1293</b>
HWBI-FUL	Insulated Top or Bottom Mount	347 x 553 x 236 mm	220 or 240 <sup>‡</sup>	1200	12 kg	<b>768</b>
HWBI-FULD	Insulated Top or Bottom Mount w/Drain	347 x 553 x 236 mm	220 or 240 <sup>‡</sup>	1200	11 kg	<b>807</b>
HWBI-FULDA	Insulated Top Mount Only w/Drain, Auto-fill	347 x 553 x 236 mm	220 or 240 <sup>‡</sup>	1215	14 kg	<b>1388</b>
HWBIB-FUL	Insulated Bottom Mount Only	352 x 561 x 236 mm	220 or 240 <sup>‡</sup>	1200	13 kg	<b>768</b>
HWBIB-FULD	Insulated Bottom Mount Only w/Drain	352 x 561 x 236 mm	220 or 240 <sup>‡</sup>	1200	13 kg	<b>807</b>
HWBIB-FULDA	Insulated Bottom Mount Only w/Drain, Auto-fill	352 x 561 x 236 mm	220 or 240 <sup>‡</sup>	1215	16 kg	<b>1388</b>
<b>High Watt</b>						
HWBH-FUL	Uninsulated Top or Bottom Mount	347 x 553 x 207 mm	220 or 240 <sup>‡</sup>	1650	10 kg	<b>\$ 673</b>
HWBH-FULD	Uninsulated Top or Bottom Mount w/Drain	347 x 553 x 207 mm	220 or 240 <sup>‡</sup>	1650	10 kg	<b>712</b>
HWBH-FULDA	Uninsulated Top or Bottom Mount w/Drain, Auto-fill	347 x 553 x 207 mm	220 or 240 <sup>‡</sup>	1665	14 kg <sup>†</sup>	<b>1293</b>
HWBHI-FUL	Insulated Top or Bottom Mount	347 x 553 x 236 mm	220 or 240 <sup>‡</sup>	1650	12 kg	<b>768</b>
HWBHI-FULD	Insulated Top or Bottom Mount w/Drain	347 x 553 x 236 mm	220 or 240 <sup>‡</sup>	1650	14 kg	<b>807</b>
HWBHI-FULDA	Insulated Top Mount Only w/Drain, Auto-fill	347 x 553 x 236 mm	220 or 240 <sup>‡</sup>	1665	14 kg	<b>1388</b>
HWBHIB-FUL	Insulated Bottom Mount Only	352 x 561 x 236 mm	220 or 240 <sup>‡</sup>	1650	14 kg	<b>768</b>
HWBHIB-FULD	Insulated Bottom Mount Only w/Drain	352 x 561 x 236 mm	220 or 240 <sup>‡</sup>	1650	14 kg	<b>807</b>
HWBHIB-FULDA	Insulated Bottom Mount Only w/Drain, Auto-fill	352 x 561 x 236 mm	220 or 240 <sup>‡</sup>	1665	16 kg	<b>1388</b>

<sup>‡</sup> 220 or 240V CE Mark available, add \$20.

<sup>†</sup> Shipping weights are approximate.

#### All Built-In Full-Size Rectangular Heated Well Models Feature:

**Voltage:** Single phase.

**Models Shipped with:** EZ locking hardware for installation (top mounted only), 914 mm conduit and a remote thermostat with lighted power switch.

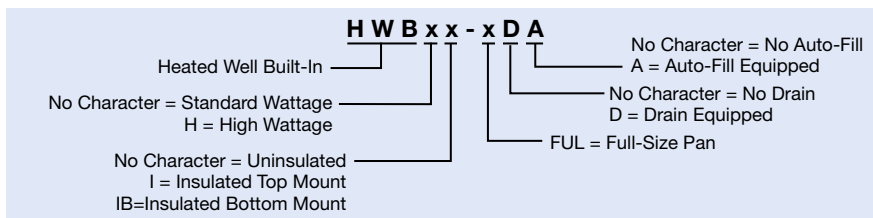

**COUNTERTOP CUTOUT  
DIMENSIONS – PAGE 23  
OPTIONS – PAGE 26  
ACCESSORIES – PAGE 34-35**

## Built-In Full-Size Heated Wells with Square Corners

## Control Options

– See page 23

Square Corner



Standard Corner



**Insulated Well Construction**  
Full-size models are available with insulation for energy savings



Optional auto-fill supply line



All Hatco Heated Wells can be ordered with or without drains (50% larger drain with exclusive flat screen ensures the pans set flush)

### BUILT-IN FULL-SIZE RECTANGULAR MODELS WITH SQUARE CORNERS

Model	Description	Dimensions W x D x H	Voltage	Watts	Ship Weight	List Price
<b>Standard Watt</b>						
HWBQ-FUL	Uninsulated Top or Bottom Mount	347 x 553 x 207 mm	220 or 240 <sup>†</sup>	1200	10 kg	\$ 748
HWBQ-FULD	Uninsulated Top or Bottom Mount w/Drain	347 x 553 x 207 mm	220 or 240 <sup>†</sup>	1200	10 kg	787
HWBQ-FULDA	Uninsulated Top or Bottom Mount w/Drain, Auto-fill	347 x 553 x 207 mm	220 or 240 <sup>†</sup>	1215	14 kg <sup>†</sup>	1368
HWBIQ-FUL	Insulated Top or Bottom Mount	347 x 553 x 236 mm	220 or 240 <sup>†</sup>	1200	12 kg	843
HWBIQ-FULD	Insulated Top or Bottom Mount w/Drain	347 x 553 x 236 mm	220 or 240 <sup>†</sup>	1200	11 kg	882
HWBIQ-FULDA	Insulated Top Mount Only w/Drain, Auto-fill	347 x 553 x 236 mm	220 or 240 <sup>†</sup>	1215	14 kg	1463
HWBIBQ-FUL	Insulated Bottom Mount Only	352 x 561 x 236 mm	220 or 240 <sup>†</sup>	1200	13 kg	843
HWBIBQ-FULD	Insulated Bottom Mount Only w/Drain	352 x 561 x 236 mm	220 or 240 <sup>†</sup>	1200	13 kg	882
HWBIBQ-FULDA	Insulated Bottom Mount Only w/Drain, Auto-fill	352 x 561 x 236 mm	220 or 240 <sup>†</sup>	1215	16 kg	1463
<b>High Watt</b>						
HWBHQ-FUL	Uninsulated Top or Bottom Mount	347 x 553 x 207 mm	220 or 240 <sup>†</sup>	1650	10 kg	\$ 748
HWBHQ-FULD	Uninsulated Top or Bottom Mount w/Drain	347 x 553 x 207 mm	220 or 240 <sup>†</sup>	1650	10 kg	787
HWBHQ-FULDA	Uninsulated Top or Bottom Mount w/Drain, Auto-fill	347 x 553 x 207 mm	220 or 240 <sup>†</sup>	1665	14 kg <sup>†</sup>	1368
HWBHIQ-FUL	Insulated Top or Bottom Mount	347 x 553 x 236 mm	220 or 240 <sup>†</sup>	1650	12 kg	843
HWBHIQ-FULD	Insulated Top or Bottom Mount w/Drain	347 x 553 x 236 mm	220 or 240 <sup>†</sup>	1650	14 kg	882
HWBHIQ-FULDA	Insulated Top Mount Only w/Drain, Auto-fill	347 x 553 x 236 mm	220 or 240 <sup>†</sup>	1665	14 kg	1463
HWBHIBQ-FUL	Insulated Bottom Mount Only	352 x 561 x 236 mm	220 or 240 <sup>†</sup>	1650	14 kg	843
HWBHIBQ-FULD	Insulated Bottom Mount Only w/Drain	352 x 561 x 236 mm	220 or 240 <sup>†</sup>	1650	14 kg	882
HWBHIBQ-FULDA	Insulated Bottom Mount Only w/Drain, Auto-fill	352 x 561 x 236 mm	220 or 240 <sup>†</sup>	1665	16 kg	1463

<sup>†</sup> 220 or 240V CE Mark available, add \$20.

<sup>†</sup> Shipping weights are approximate.

**All Built-In Full-Size Rectangular Heated Well Models Feature:**

**Voltage:** Single phase.

**Models Shipped with:** EZ locking hardware for installation (top mounted only), 914 mm conduit and a remote thermostat with lighted power switch.

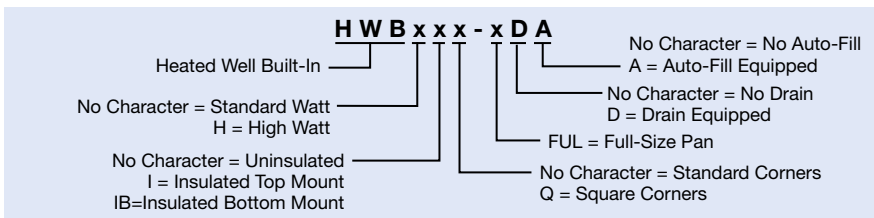

**COUNTERTOP CUTOUT DIMENSIONS – PAGE 23**  
**OPTIONS – PAGE 26**  
**ACCESSORIES – PAGE 34-35**



**HWBL-43D and HWBLI-FULD** with accessory food pans (shown with **GR2AHL** with standard *Designer* non-adjustable stands and optional *Designer* color and sneeze guards)



### OPTIONS (available at time of purchase only)

**Designer Colors (Flush Mount Control Box Bezel, not available for HWB-FUL w/cord) – Non-standard colors are non-returnable –**

<b>RED</b>	Warm Red	<b>\$36</b>
<b>BLACK</b>	Black	<b>36</b>
<b>GRAY</b>	Gray Granite	<b>36</b>
<b>WHITE</b>	White Granite	<b>36</b>
<b>NAVY</b>	Navy Blue	<b>36</b>
<b>GREEN</b>	Hunter Green	<b>36</b>
<b>COPPER</b>	Antique Copper	<b>36</b>
<b>HWB-LEAD</b>	Power Supply Lead Wire (Lead Wire only – Conduit not included)	<b>per 305 mm \$ 8</b>
<b>COND-6</b>	1829 mm Flexible Conduit (914 mm standard) – Not available on models with HWB-, HWBI-CORD	<b>34</b>
<b>HWB-CORD</b>	HWB-FUL with Cord Standard (Shown below)	<b>add 28</b>
	All models except Auto-fill models	<b>add 28</b>
	HWBI-FUL with Cord Standard	<b>add 28</b>
<b>HWBI-CORD</b>	Top Mount: HWBI-FUL, -FULD and HWBI-FUL, FULD	<b>add 28</b>
<b>HWBIB-BRKT</b>	Bottom Mount: HWBIB-FULDA, and HWBIB-FULDA	<b>add 19</b>
	Mounting Bracket for Insulated Bottom Mount (HWBIB series)	<b>add 19</b>
<b>Control Options –</b>		
<b>HWB-TSTAT</b>	Thermostat with 1829 mm Capillary (Not available for auto-fill models)	<b>68</b>
	Larger Recessed Thermostatic Control (not available for auto-fill models, standard on 220 or 240V export models)	<b>No Charge</b>
<b>HWB-RTC</b>	ITC Control (not available for auto-fill models, units without a drain or low watt configurations)	<b>228</b>

**ACCESSORIES – PAGE 34-35**  
**COLORS AND FINISHES – INSIDE BACK COVER**



Optional ITC Control – Not for low watt configurations – shown with optional control box bezel in *Designer* White Granite

**HWB-CORD**  
HWB with optional cord





## Drop-In 4/3-Size Heated Wells

Convenient 4/3-Size Wells hold heated foods at safe-serving temperatures. Like the full-size models, Hatco units offer a larger drain with a flat drain screen, more consistent holding temperatures, heavier stainless steel construction, easier-to-service design for quick change of components and a remote thermostat with separate power switch.

- Rectangular 4/3-size wells
- Low (120V only), standard and high watt
- Available with or without a drain (easy to clean with a larger drain and a flat screen)
- Easy access design allows for quick element or thermostat change
- Accessory mounting kits for combustible countertops available
- Accessory adapters to convert 4/3-size wells to hold round pans

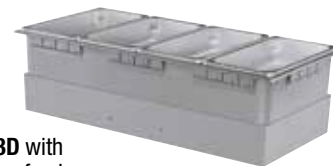

**HWB-43D** with accessory food pans (single unit holding 4 third-size pans)

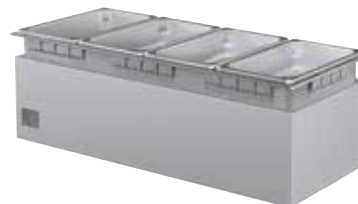

**HWBI-43D** with accessory food pans (single unit holding 4 third-size pans)

### DROP-IN 4/3-SIZE RECTANGULAR MODELS

Model	Description	Dimensions W x D x H	Voltage	Watts	Ship Weight	List Price
<b>Standard Watt</b>						
<b>HWB-43</b>	Uninsulated	346 x 727 x 219 mm	220 or 240 <sup>†</sup>	1200	11 kg	<b>\$ 749</b>
<b>HWB-43D</b>	Uninsulated w/Drain	346 x 727 x 219 mm	220 or 240 <sup>†</sup>	1200	11 kg	<b>788</b>
<b>HWB-43DA</b>	Uninsulated w/Drain, Auto-fill	346 x 727 x 219 mm	220 or 240 <sup>†</sup>	1215	12 kg	<b>1369</b>
<b>HWBI-43</b>	Insulated	346 x 727 x 244 mm	220 or 240 <sup>†</sup>	1200	14 kg	<b>844</b>
<b>HWBI-43D</b>	Insulated w/Drain	346 x 727 x 244 mm	220 or 240 <sup>†</sup>	1200	14 kg	<b>883</b>
<b>High Watt</b>						
<b>HWBH-43</b>	Uninsulated	346 x 727 x 219 mm	220 or 240 <sup>†</sup>	1650	11 kg	<b>\$ 749</b>
<b>HWBH-43D</b>	Uninsulated w/Drain	346 x 727 x 219 mm	220 or 240 <sup>†</sup>	1650	11 kg	<b>788</b>
<b>HWBH-43DA</b>	Uninsulated w/Drain, Auto-fill	346 x 727 x 219 mm	220 or 240 <sup>†</sup>	1665	14 kg	<b>1369</b>
<b>HWBHI-43</b>	Insulated	346 x 727 x 244 mm	220 or 240 <sup>†</sup>	1650	14 kg	<b>844</b>
<b>HWBHI-43D</b>	Insulated w/Drain	346 x 727 x 244 mm	220 or 240 <sup>†</sup>	1650	14 kg	<b>883</b>

<sup>†</sup> 220 or 240V CE Mark available, add \$20.

**All Drop-In 4/3-Size Rectangular Heated Well Models Feature:**

**Voltage:** Single phase.

**Models Shipped with:** EZ locking hardware for installation, 914 mm (36") conduit and a remote thermostat with lighted power switch.

### OPTIONS (available at time of purchase only)

<b>HWB-LEAD</b>	Power Supply Lead Wire (Lead Wire only – Conduit not included)	<b>per 305 mm \$ 8</b>
<b>COND-6</b>	1829 mm Flexible Conduit (914 mm standard)	<b>34</b>
<b>HWB-TSTAT</b>	Thermostat with 1829 mm Capillary	<b>68</b>
<b>HWB-RTC</b>	Larger Recessed Thermostatic Control (not available for auto-fill, standard on 220 or 240V export models)	<b>No Charge</b>
<b>HWB-ITC</b>	ITC Control (not available for auto-fill models)	<b>228</b>
<b>HWB-AFL</b>	Models HWB, HWBH, HWBL-43DA only - Left water fill hole (front is standard)	<b>No Charge</b>
<b>HWB-AFR</b>	Models HWB, HWBH, HWBL-43DA only - Right water fill hole (front is standard)	<b>No Charge</b>

**Designer Colors (Control Box Bezel) – Non-standard colors are non-returnable) –**

<b>RED</b>	Warm Red	<b>\$36</b>
<b>BLACK</b>	Black	<b>36</b>
<b>GRAY</b>	Gray Granite	<b>36</b>
<b>WHITE</b>	White Granite	<b>36</b>
<b>NAVY</b>	Navy Blue	<b>36</b>
<b>GREEN</b>	Hunter Green	<b>36</b>
<b>COPPER</b>	Antique Copper	<b>36</b>



**Insulated Well Construction**  
Full-size models are available with insulation for energy savings

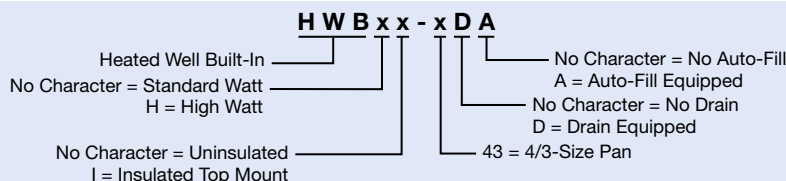

**CONTROL OPTIONS – PAGE 23**  
**COUNTERTOP CUT-OUT DIMENSIONS – PAGE 23**  
**ACCESSORIES – PAGE 34-35**  
**COLORS AND FINISHES – INSIDE BACK COVER**



## Drop-In Round Heated Uninsulated Wells

Keeping hot food at safe-serving temperatures is critical to any foodservice operation – and Hatco has the Heated Wells to meet the demands of any serving application. Thermostatic controls monitor and regulate the temperature of the well for more accurate heat and energy savings. Hatco controls feature a separate On/Off switch, which allows a previously determined setting to be maintained.

- 4-, 7- and 10-liter Round Wells
- Standard or high watt (4-liter standard watt only)
- With or without drain
- EZ locking hardware for easy top mount installation
- Accessory mounting kits for combustible countertops available

## Control Options

- Larger front-mounted recessed thermostatic control box with lighted On/Off rocker switch and angled recessed controls for easy readability
- Optional ITC control with large control box available for easier reading on 7- or 10-liter (7- or 11-quart) standard or high watt configurations

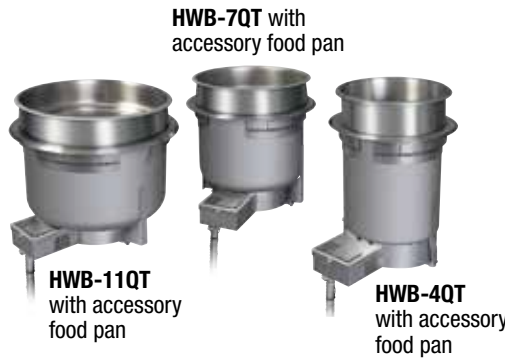

Optional ITC control – (not for 4-liter [4-quart] Round Wells or units without a drain) shown with optional control box bezel in Designer White Granite



Larger recessed thermostatic control at no charge

### DROP-IN ROUND MODELS – UNINSULATED

Model	Description	Dimensions Dia. x H	Voltage	Watts	Ship Weight	List Price
<b>4-Liter (4-Quart) – Standard Watt</b>						
HWB-4QT	Top Mount	212 x 251 mm	220 or 240 <sup>†</sup>	600	5 kg	<b>\$642</b>
HWB-4QTD	Top Mount w/Drain	212 x 251 mm	220 or 240 <sup>†</sup>	600	5 kg	<b>681</b>
<b>7-Liter (7-Quart) – Standard Watt</b>						
HWB-7QT	Top Mount	262 x 228 mm	220 or 240 <sup>†</sup>	600	6 kg	<b>\$642</b>
HWB-7QTD	Top Mount w/Drain	262 x 228 mm	220 or 240 <sup>†</sup>	600	6 kg	<b>681</b>
<b>7-Liter (7-Quart) – High Watt</b>						
HWBH-7QT	Top Mount	262 x 228 mm	220 or 240 <sup>†</sup>	800	6 kg	<b>\$642</b>
HWBH-7QTD	Top Mount w/Drain	262 x 228 mm	220 or 240 <sup>†</sup>	800	6 kg	<b>681</b>
<b>10-Liter (11-Quart) – Standard Watt</b>						
HWB-11QT	Top Mount	313 x 228 mm	220 or 240 <sup>†</sup>	600	6 kg	<b>\$642</b>
HWB-11QTD	Top Mount w/Drain	313 x 228 mm	220 or 240 <sup>†</sup>	600	6 kg	<b>681</b>
<b>10-Liter (11-Quart) – High Watt</b>						
HWBH-11QT	Top Mount	313 x 228 mm	220 or 240 <sup>†</sup>	800	6 kg	<b>\$642</b>
HWBH-11QTD	Top Mount w/Drain	313 x 228 mm	220 or 240 <sup>†</sup>	800	6 kg	<b>681</b>

<sup>†</sup> 220 or 240V CE Mark available, add \$20.

**All Drop-In Round Uninsulated Heated Well Models Feature:**

**Voltage:** Single phase.

**Models Shipped with:** EZ locking hardware for installation, 914 mm conduit and a remote thermostat with lighted power switch.

### OPTIONS (available at time of purchase only)

HWB-LEAD	Power Supply Lead Wire (Lead Wire only – Conduit not included)	per 305 mm \$ 8
COND-6	1829 mm Flexible Conduit (914 mm standard)	34
HWB-TSTAT	Thermostat with 1829 mm Capillary	68
HWB-RTC	Larger Recessed Thermostatic Control (not available for auto-fill, standard on 220 or 240V export models)	No Charge
HWB-ITC	ITC Control with large Control Box for 7- and 10-liter Drop-In Round Wells only	228

### Designer Colors (Control Box Bezel – Non-standard colors are non-returnable) –

RED	Warm Red	\$36
BLACK	Black	36
GRAY	Gray Granite	36
WHITE	White Granite	36
NAVY	Navy Blue	36
GREEN	Hunter Green	36
COPPER	Antique Copper	36

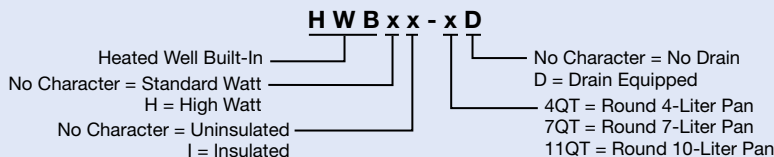

**COUNTERTOP CUTOUT DIMENSIONS – PAGE 23**  
**ACCESSORIES – PAGE 34-35**  
**COLORS AND FINISHES – INSIDE BACK COVER**

## Drop-In Round Insulated Heated Wells

Hatco Drop-In Round Insulated Heated Wells provide flexibility and quality, with many options to choose from. These units hold steam table food hot and fresh with self-adjusting thermostats that monitor the actual temperatures and control the heat only when needed.

- Available in insulated 4-, 7- and 10-liter Round Wells
- Standard or high watt (4-liter standard watt only)
- Controls feature a separate lighted ON/OFF rocker switch and
- Easy service access to heating elements and thermostats
- Mounting kits for combustible countertops available
- Auto-Fill models available in 7 and 10 liter round wells

## Control Options

- Larger front-mounted recessed thermostatic control box with lighted On/Off rocker switch and angled recessed controls for easy readability

HWB-7QT with accessory food pan



HWBI-11QT with accessory food pan



Larger recessed thermostatic control at no charge

### DROP-IN ROUND MODELS – INSULATED

Model	Description	Dimensions Dia. x H	Voltage	Watts	Ship Weight	List Price
<b>4-Liter (4-Quart) – Standard Watt</b>						
HWBI-4QT	Top Mount	209 x 251 mm	220 or 240 <sup>†</sup>	600	5 kg	<b>\$ 737</b>
HWBI-4QTD	Top Mount w/Drain	209 x 251 mm	220 or 240 <sup>†</sup>	600	5 kg	<b>776</b>
<b>7-Liter (7-Quart) – Standard Watt</b>						
HWBI-7QT	Top Mount	262 x 228 mm	220 or 240 <sup>†</sup>	600	6 kg	<b>\$ 737</b>
HWBI-7QTD	Top Mount w/Drain	262 x 228 mm	220 or 240 <sup>†</sup>	600	6 kg	<b>776</b>
HWBI-7QTDA	Top Mount w/Drain, Auto-fill	262 x 228 mm	220 or 240 <sup>†</sup>	615	8.6 kg	<b>1357</b>
<b>7-Liter (7-Quart) – High Watt</b>						
HWBHI-7QT	Top Mount	262 x 228 mm	220 or 240 <sup>†</sup>	800	6 kg	<b>\$ 737</b>
HWBHI-7QTD	Top Mount w/Drain	262 x 228 mm	220 or 240 <sup>†</sup>	800	6 kg	<b>776</b>
HWBHI-7QTDA	Top Mount w/Drain, Auto-fill	262 x 222 mm	220 or 240 <sup>†</sup>	815	8.6 kg	<b>1357</b>
<b>10-Liter (11-Quart) – Standard Watt</b>						
HWBI-11QT	Top Mount	313 x 228 mm	220 or 240 <sup>†</sup>	600	6 kg	<b>\$ 737</b>
HWBI-11QTD	Top Mount w/Drain	313 x 228 mm	220 or 240 <sup>†</sup>	600	6 kg	<b>776</b>
HWBI-11QTDA	Top Mount w/Drain, Auto-fill	313 x 228 mm	220 or 240 <sup>†</sup>	615	6 kg	<b>1357</b>
<b>10-Liter (11-Quart) – High Watt</b>						
HWBHI-11QT	Top Mount	313 x 228 mm	220 or 240 <sup>†</sup>	800	6 kg	<b>\$ 737</b>
HWBHI-11QTD	Top Mount w/Drain	313 x 228 mm	220 or 240 <sup>†</sup>	800	6 kg	<b>776</b>
HWBHI-11QTDA	Top Mount w/Drain, Auto-fill	313 x 228 mm	220 or 240 <sup>†</sup>	815	9 kg	<b>1357</b>

<sup>†</sup> 220 or 240V CE Mark available, add \$20.

**All Drop-In Round Insulated Heated Well Models Feature:**

**Voltage:** Single phase.

**Models Shipped with:** 914 mm conduit and a remote thermostat with lighted power switch.

### OPTIONS (available at time of purchase only)

HWB-LEAD	Power Supply Lead Wire (Lead Wire only – Conduit not included)	per 305 mm \$ 8
COND-6	1829 mm Flexible Conduit (914 mm standard)	34
HWB-TSTAT	Thermostat with 1829 mm Capillary	68
HWB-RTC	Larger Recessed Thermostatic Control (not available for auto-fill, standard on 220 or 240V export models)	No Charge

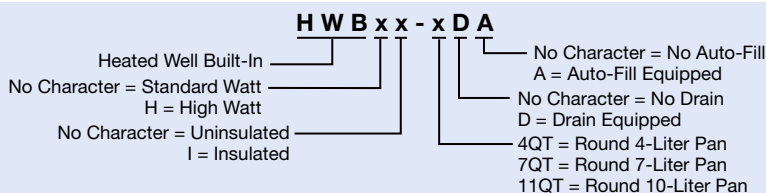

**COUNTERTOP CUTOUT DIMENSIONS – PAGE 23**  
**ACCESSORIES – PAGE 34-35**





## Built-In Full-Size Heated Wells - Fabricator Components

Having the same great features as all of the Hatco Heated Wells, plus the added benefit of allowing fabricators the freedom to design their own steam tables, these units hold hot food products at safe-serving temperatures.

- Without conduit and control box enclosure
- Thermostatic or infinite controls available (infinite switch option not available on 120V high watt)
- With or without drains
- Full-size rectangular wells
- Low, standard and high watt models

**NOTE:** Fabricator models are not a CE offering, items are sold as components for fabricator self certification.



**HWBRT-FULD** with accessory food pan



**HWBIRT-FULD** with accessory food pan

**HWBIBRT-FULD** with accessory food pan

**Standard Corner**



### BUILT-IN FULL-SIZE RECTANGULAR FABRICATOR COMPONENTS

Model <sup>■</sup>	Description	Dimensions (Top Mount) W x D x H	Voltage	Watts	Ship Weight	List Price
<b>Standard Watt</b>						
<b>HWBRT-FUL</b>	Uninsulated Top or Bottom Mount	347 x 553 x 207 mm	220 or 240*	1200	9 kg	<b>\$578</b>
<b>HWBRT-FULD</b>	Uninsulated Top or Bottom Mount w/Drain	347 x 553 x 207 mm	220 or 240*	1200	9 kg	<b>617</b>
<b>HWBRN-FUL</b>	Uninsulated Top or Bottom Mount	347 x 553 x 207 mm	220 or 240*	1200	9 kg	<b>578</b>
<b>HWBRN-FULD</b>	Uninsulated Top or Bottom Mount w/Drain	347 x 553 x 207 mm	220 or 240*	1200	9 kg	<b>617</b>
<b>HWBIRT-FUL</b>	Insulated Top or Bottom Mount	347 x 553 x 236 mm	220 or 240*	1200	11 kg	<b>673</b>
<b>HWBIRT-FULD</b>	Insulated Top or Bottom Mount w/Drain	347 x 553 x 236 mm	220 or 240*	1200	12 kg	<b>712</b>
<b>HWBIBRT-FUL</b>	Insulated Bottom Mount Only	352 x 561 x 236 mm	220 or 240*	1200	12 kg	<b>673</b>
<b>HWBIBRT-FULD</b>	Insulated Bottom Mount Only w/Drain	352 x 561 x 236 mm	220 or 240*	1200	12 kg	<b>712</b>
<b>High Watt</b>						
<b>HWBHRT-FUL</b>	Uninsulated Top or Bottom Mount	347 x 553 x 207 mm	220 or 240*	1650	10 kg	<b>\$578</b>
<b>HWBHRT-FULD</b>	Uninsulated Top or Bottom Mount w/Drain	347 x 553 x 207 mm	220 or 240*	1650	8 kg	<b>617</b>
<b>HWBHRT-FUL</b>	Uninsulated Top or Bottom Mount	347 x 553 x 207 mm	220 or 240*	1650	10 kg	<b>578</b>
<b>HWBHRT-FULD</b>	Uninsulated Top or Bottom Mount w/Drain	347 x 553 x 207 mm	220 or 240*	1650	9 kg	<b>617</b>
<b>HWBHIRT-FUL</b>	Insulated Top or Bottom Mount	347 x 553 x 236 mm	220 or 240*	1650	12 kg	<b>673</b>
<b>HWBHIRT-FULD</b>	Insulated Top or Bottom Mount w/Drain	347 x 553 x 236 mm	220 or 240*	1650	13 kg	<b>712</b>
<b>HWBHIBRT-FUL</b>	Insulated Bottom Mount Only	352 x 561 x 236 mm	220 or 240*	1650	13 kg	<b>673</b>
<b>HWBHIBRT-FULD</b>	Insulated Bottom Mount Only w/Drain	352 x 561 x 236 mm	220 or 240*	1650	13 kg	<b>712</b>

■ "RT" added to model name indicates unit with thermostat control, lit rocker switch and 914 mm capillary. "RN" added to model name indicates unit with infinite switch control, pilot light and 914 mm leads.

\* CE Mark not available.

**All Built-In Full-Size Rectangular Fabricator Heated Well Models Feature:**

**Voltage:** Single phase.

**Models shipped with:** EZ locking hardware for installation (top mounted only).

### OPTIONS (available at time of purchase only)

<b>HWB-LEAD-UR</b>	Power Supply Lead Wire for "RN" Components (Lead Wire only - Conduit not included)	<b>per 305 mm \$ 8</b>
<b>HWB-TSTAT-UR</b>	Thermostat with 1829 mm Capillary for "RT" Components (Thermostat only - Conduit not included)	<b>47</b>

**Insulated Well Construction**  
Full-size models are available with insulation for energy savings



#### H W B x x x - x D

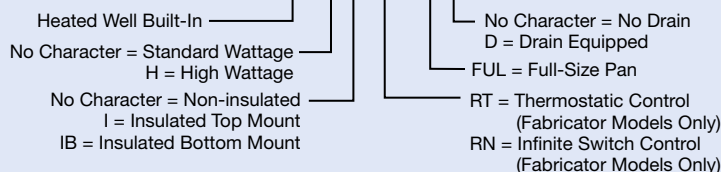

**COUNTERTOP CUTOUT DIMENSIONS – PAGE 23**  
**CONTROL OPTIONS – PAGE 23**  
**ACCESSORIES – PAGE 34-35**

## Built-In Full-Size Heated Wells with Square Corners - Fabricator Components

Square Corner



Standard Corner



All Hatco Heated Wells can be ordered with or without drains (50% larger drain with exclusive flat screen ensures the pans set flush)

## Control Options - UR and C-UR Components

- See page 23

**NOTE:** Fabricator models are not a CE offering, items are sold as components for fabricator self certification.

### BUILT-IN FULL-SIZE RECTANGULAR FABRICATOR COMPONENTS

Model <sup>■</sup>	Description	Dimensions W x D x H	Voltage	Watts	Ship Weight	List Price
<b>Standard Watt</b>						
<b>HWBRTQ-FUL</b>	Uninsulated Top or Bottom Mount	347 x 553 x 207 mm	220 or 240 <sup>•</sup>	1200	9 kg	<b>\$653</b>
<b>HWBRTQ-FULD</b>	Uninsulated Top or Bottom Mount w/Drain	347 x 553 x 207 mm	220 or 240 <sup>•</sup>	1200	9 kg	<b>692</b>
<b>HWBRNQ-FUL</b>	Uninsulated Top or Bottom Mount	347 x 553 x 207 mm	220 or 240 <sup>•</sup>	1200	9 kg	<b>653</b>
<b>HWBRNQ-FULD</b>	Uninsulated Top or Bottom Mount w/Drain	347 x 553 x 207 mm	220 or 240 <sup>•</sup>	1200	9 kg	<b>692</b>
<b>HWBIRTQ-FUL</b>	Insulated Top or Bottom Mount	347 x 553 x 236 mm	220 or 240 <sup>•</sup>	1200	11 kg	<b>748</b>
<b>HWBIRTQ-FULD</b>	Insulated Top or Bottom Mount w/Drain	347 x 553 x 236 mm	220 or 240 <sup>•</sup>	1200	12 kg	<b>787</b>
<b>HWBIBRTQ-FUL</b>	Insulated Bottom Mount Only	352 x 561 x 236 mm	220 or 240 <sup>•</sup>	1200	12 kg	<b>748</b>
<b>HWBIBRTQ-FULD</b>	Insulated Bottom Mount Only w/Drain	352 x 561 x 236 mm	220 or 240 <sup>•</sup>	1200	12 kg	<b>787</b>
<b>High Watt</b>						
<b>HWBHRTQ-FUL</b>	Uninsulated Top or Bottom Mount	347 x 553 x 207 mm	220 or 240 <sup>•</sup>	1650	10 kg	<b>\$653</b>
<b>HWBHRTQ-FULD</b>	Uninsulated Top or Bottom Mount w/Drain	347 x 553 x 207 mm	220 or 240 <sup>•</sup>	1650	8 kg	<b>692</b>
<b>HWBHRNQ-FUL</b>	Uninsulated Top or Bottom Mount	347 x 553 x 207 mm	220 or 240 <sup>•</sup>	1650	10 kg	<b>653</b>
<b>HWBHRNQ-FULD</b>	Uninsulated Top or Bottom Mount w/Drain	347 x 553 x 207 mm	220 or 240 <sup>•</sup>	1650	9 kg	<b>692</b>
<b>HWBHIRTQ-FUL</b>	Insulated Top or Bottom Mount	347 x 553 x 236 mm	220 or 240 <sup>•</sup>	1650	12 kg	<b>748</b>
<b>HWBHIRTQ-FULD</b>	Insulated Top or Bottom Mount w/Drain	347 x 553 x 236 mm	220 or 240 <sup>•</sup>	1650	13 kg	<b>787</b>
<b>HWBHIBRTQ-FUL</b>	Insulated Bottom Mount Only	352 x 561 x 236 mm	220 or 240 <sup>•</sup>	1650	13 kg	<b>748</b>
<b>HWBHIBRTQ-FULD</b>	Insulated Bottom Mount Only w/Drain	352 x 561 x 236 mm	220 or 240 <sup>•</sup>	1650	13 kg	<b>787</b>

■ "RT" added to model name indicates unit with thermostat control, lit rocker switch and 914 mm capillary. "RN" added to model name indicates unit with infinite switch control, pilot light and 914 mm leads.

• CE Mark not available.

#### All Built-In Full-Size Rectangular Fabricator Heated Well Models Feature:

Voltage: Single phase.

Models shipped with: EZ locking hardware for installation (top mounted only).

#### OPTIONS (available at time of purchase only)

<b>HWB-LEAD-UR</b>	Power Supply Lead Wire for "RN" Components (Lead Wire only - Conduit not included)	per 305 mm \$ 8
<b>HWB-TSTAT-UR</b>	Thermostat with 1829 mm Capillary for "RT" Components (Thermostat only - Conduit not included)	47

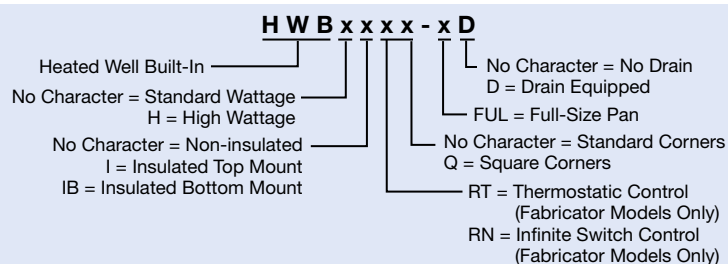

COUNTERTOP CUTOUT DIMENSIONS - PAGE 23  
CONTROL OPTIONS - PAGE 23  
ACCESSORIES - PAGE 34-35



## Drop-In 4/3-Size Heated Wells - Fabricator Components

Having the same great features as all of the Hatco Heated Wells, plus the added benefit of allowing fabricators the freedom to design their own steam tables, these units hold hot food products at safe-serving temperatures.

**NOTE:** Fabricator models are not a CE offering, items are sold as components for fabricator self certification.

- Without conduit and control box enclosure
- Thermostatic or infinite controls available (infinite switch option not available on 120V high watt)
- With or without drains
- 4/3-size rectangular wells
- Low, standard and high watt models



**HWBRT-43D** with accessory food pans (single unit holding 4 third-size pans)

## Control Options

The Fabricator models can have the following control choices:

- Thermostatic controls, which feature an On/Off switch with light
- Infinite controls with indicator light



Thermostatic control



Infinite control

### CONTROL CUTOUT DIMENSIONS

Control	Width	Height
Thermostatic	54 mm	86 mm
Infinite	54 mm	86 mm

### DROP-IN 4/3-SIZE RECTANGULAR FABRICATOR COMPONENTS

Model <sup>■</sup>	Description	Dimensions W x D x H	Voltage	Watts	Ship Weight	List Price
<b>Standard Watt</b>						
<b>HWBRT-43</b>	Uninsulated	345 x 726 x 207 mm	220 or 240 <sup>•</sup>	1200	11 kg	<b>\$654</b>
<b>HWBRT-43D</b>	Uninsulated w/Drain	345 x 726 x 207 mm	220 or 240 <sup>•</sup>	1200	10 kg	<b>693</b>
<b>HWBRN-43</b>	Uninsulated	345 x 726 x 207 mm	220 or 240 <sup>•</sup>	1200	10 kg	<b>654</b>
<b>HWBRN-43D</b>	Uninsulated w/Drain	345 x 726 x 207 mm	220 or 240 <sup>•</sup>	1200	10 kg	<b>693</b>
<b>High Watt</b>						
<b>HWBHRT-43</b>	Uninsulated	345 x 726 x 207 mm	220 or 240 <sup>•</sup>	1650	14 kg	<b>\$654</b>
<b>HWBHRT-43D</b>	Uninsulated w/Drain	345 x 726 x 207 mm	220 or 240 <sup>•</sup>	1650	10 kg	<b>693</b>
<b>HWBHRN-43</b>	Uninsulated	345 x 726 x 207 mm	220 or 240 <sup>•</sup>	1650	14 kg	<b>654</b>
<b>HWBHRN-43D</b>	Uninsulated w/Drain	345 x 726 x 207 mm	220 or 240 <sup>•</sup>	1650	15 kg	<b>693</b>

- "RT" added to model name indicates unit with thermostat control, lit rocker switch and 914 mm capillary.
- "RN" added to model name indicates unit with infinite switch control, pilot light and 914 mm leads.
- CE Mark not available.

**All Drop-In 4/3-Size Rectangular Fabricator Heated Well Models Feature:**

**Voltage:** Single phase.

**Models Shipped with:** EZ locking hardware for installation.

### OPTIONS (available at time of purchase only)

<b>HWB-LEAD-UR</b>	Power Supply Lead Wire for "RN" Components (Lead Wire only - Conduit not included)	<b>per 305 mm \$ 8</b>
<b>HWB-TSTAT-UR</b>	Thermostat with 1829 mm Capillary for "RT" Components (Thermostat only - Conduit not included)	<b>47</b>

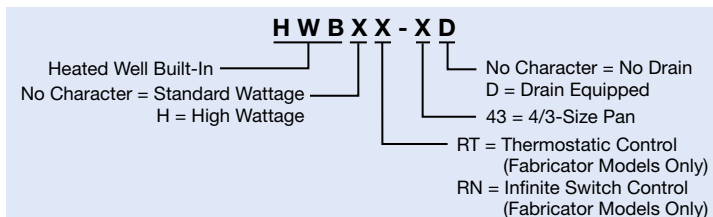

**COUNTERTOP CUT-OUT DIMENSIONS - PAGE 23**  
**ACCESSORIES - PAGE 34-35**



## Drop-In Round Heated Wells - Fabricator Components

Ideal for the fabricator who wants to design a specific steam table layout. Easy to install, and easy to service, the Round Heated Wells come with control, size, drain and wattage choices.

- 4-, 7- and 10-liter round wells
- Standard or high watt (4-liter standard watt only)
- With or without drain
- Thermostatic or infinite controls available
- Without conduit and control box enclosure

## Control Options

– See page 32

**NOTE:** Fabricator models are not a CE offering, items are sold as components for fabricator self certification.

HWBRT-11QT with accessory food pan (not included)



HWBRT-7QT with accessory food pan (not included)

HWBRT-4QT with accessory food pan (not included)

### DROP-IN ROUND FABRICATOR COMPONENTS – UNINSULATED

Model #	Description	Dimensions (Dia. x H)	Voltage	Watts	Ship Weight	List Price
<b>4-Liter (4-Quart) – Standard Watt</b>						
HWBRT-4QT	Top Mount	212 x 249 mm	220, or 240*	600	4 kg	\$547
HWBRT-4QTD	Top Mount w/Drain	212 x 249 mm	220, or 240*	600	4 kg	586
HWBRN-4QT	Top Mount	212 x 249 mm	220, or 240*	600	3 kg	547
HWBRN-4QTD	Top Mount w/Drain	212 x 249 mm	220, or 240*	600	4 kg	586
<b>7-Liter (7-Quart) – Standard Watt</b>						
HWBRT-7QT	Top Mount	262 x 222 mm	220, or 240*	600	5 kg	\$547
HWBRT-7QTD	Top Mount w/Drain	262 x 222 mm	220, or 240*	600	5 kg	586
HWBRN-7QT	Top Mount	262 x 222 mm	220, or 240*	600	3 kg	547
HWBRN-7QTD	Top Mount w/Drain	262 x 222 mm	220, or 240*	600	5 kg	586
<b>7-Liter (7-Quart) – High Watt</b>						
HWBHRT-7QT	Top Mount	262 x 222 mm	220, or 240*	800	5 kg	\$547
HWBHRT-7QTD	Top Mount w/Drain	262 x 222 mm	220, or 240*	800	4 kg	586
HWBHRN-7QT	Top Mount	262 x 222 mm	220, or 240*	800	3 kg	547
HWBHRN-7QTD	Top Mount w/Drain	262 x 222 mm	220, or 240*	800	6 kg	586
<b>10-Liter (11-Quart) – Standard Watt</b>						
HWBRT-11QT	Top Mount	313 x 221 mm	220, or 240*	600	5 kg	\$547
HWBRT-11QTD	Top Mount w/Drain	313 x 221 mm	220, or 240*	600	5 kg	586
HWBRN-11QT	Top Mount	313 x 221 mm	220, or 240*	600	5 kg	547
HWBRN-11QTD	Top Mount w/Drain	313 x 221 mm	220, or 240*	600	6 kg	586
<b>10-Liter (11-Quart) – High Watt</b>						
HWBHRT-11QT	Top Mount	313 x 221 mm	220, or 240*	800	5 kg	\$547
HWBHRT-11QTD	Top Mount w/Drain	313 x 221 mm	220, or 240*	800	5 kg	586
HWBHRN-11QT	Top Mount	313 x 221 mm	220, or 240*	800	5 kg	547
HWBHRN-11QTD	Top Mount w/Drain	313 x 221 mm	220, or 240*	800	6 kg	586

\* "RT" added to model name indicates unit with thermostat control, lit rocker switch and 914 mm capillary. "RN" added to model name indicates unit with infinite switch control, pilot light and 914 mm leads. "D" added to model name indicates unit with drain.

• CE Mark not available.

#### All Drop-In Round Fabricator Heated Well Models Feature:

Voltage: Single phase.

Models Shipped with: EZ locking hardware for installation.

#### OPTIONS (available at time of purchase only), Fabricator Components Only –

	Power Supply Lead Wire (Lead Wire only – Conduit not included)	per 305 mm \$ 8
HWB-LEAD-UR	Thermostat with 1829 mm Capillary	47
HWB-TSTAT-UR		

#### COUNTERTOP CUT-OUT DIMENSIONS – PAGE 23 ACCESSORIES – PAGE 34-35

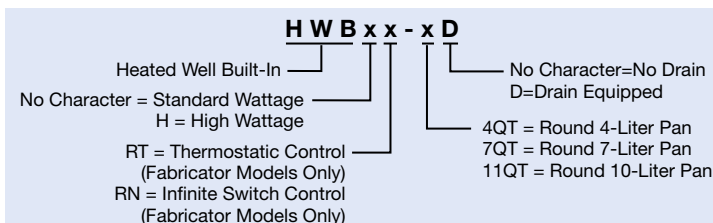

**Heated Well Accessories** (available for purchase at any time)



**FTB-2**  
with accessory  
full-size  
sheet pans

**HWBI-2**  
with accessory  
half and third-size  
food pans

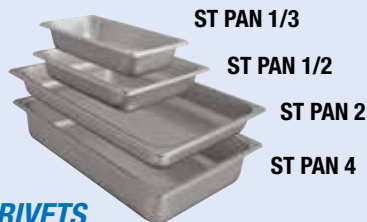

**PANS – LIDS – TRIVETS**

<b>ST PAN 1/3</b>	Third-Size Stainless Steel Pan – 324 W x 175 D x 64 H mm	<b>\$50</b>
<b>ST PAN 1/2</b>	Half-Size Stainless Steel Pan – 324 W x 264 D x 64 H mm	<b>56</b>
<b>ST PAN 2</b>	Full-Size Stainless Steel Pan – 324 W x 527 D x 64 H mm	<b>68</b>
<b>ST PAN 4</b>	Full-Size Stainless Steel Pan – 324 W x 527 D x 102 H mm	<b>86</b>
<b>HDW 6" PAN</b>	Full-Size Stainless Steel Pan – 324 W x 527 D x 152 H mm	<b>94</b>
<b>4QT-PAN</b>	4-Liter Round Pan	<b>89</b>
<b>7QT-PAN</b>	7-Liter Round Pan	<b>99</b>
<b>11QT-PAN</b>	10-Liter Round Pan	<b>109</b>

**Notched Lid for Round Pans –**

<b>4QT-LID-1</b>	4-Liter Round, Notched, Solid Lid	<b>\$42</b>
<b>7QT-LID-1</b>	7-Liter Round, Notched, Solid Lid	<b>52</b>
<b>11QT-LID-1</b>	10-Liter Round, Notched, Solid Lid	<b>62</b>

**Hinged Lid for Round Pans –**

<b>4QT-LID</b>	4-Liter Round, Hinged and Notched Lid	<b>\$55</b>
<b>7QT-LID</b>	7-Liter Round, Hinged and Notched Lid	<b>72</b>
<b>11QT-LID</b>	10-Liter Round, Hinged and Notched Lid	<b>89</b>

**Wire Trivets Stainless –**

<b>TRIVET (1/2)SS</b>	Half-Size – 259 W x 194 D mm	<b>\$ 94</b>
<b>TRIVET SS</b>	Full-Size – 259 W x 457 D mm	<b>128</b>

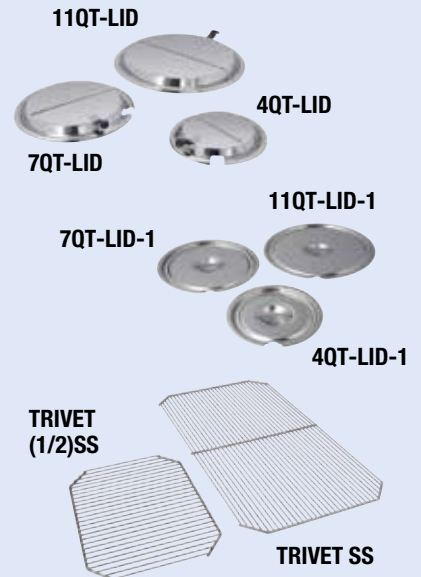

**ADAPTERS, SUPPORT BARS, MOUNTING KITS, VALVES – PAGE 35**

## Heated Well Accessories

(available for purchase at any time)

**HWB-2-7Q**  
shown with two  
7QT-PAN and  
7QT-LID-1

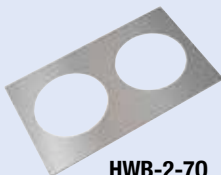

**HWB-2-7Q**



**HWB-2-11Q**



**HWB-3-4Q**

### ADAPTERS – SUPPORT BARS

<b>HWB-2-7Q</b>	Adapter to convert warmer to hold two 7-Liter Inserts (model HWBI & HWB-FUL series only)	<b>\$76</b>
<b>HWB-3-4Q</b>	Adapter to convert warmer to hold three 4-Liter Inserts (model HWBI & HWB-FUL series only)	<b>76</b>
<b>HWB-2-11Q</b>	Adapter to Convert warmer to hold two 10-Liter Inserts (model HWB-43 series only)	<b>95</b>
<b>HWB12BAR</b>	305 mm Pan Support Bar for Built-In and Drop-In Heated Wells	<b>16</b>
<b>HWB20BAR</b>	508 mm Pan Support Bar for Built-In and Drop-In Heated Wells	<b>19</b>
<b>HWBGM12BAR</b>	305 mm Pan Support Bar for Drop-In Modular/Ganged Models	<b>16</b>
<b>HWBGM20BAR</b>	508 mm Pan Support Bar for Drop-In Modular/Ganged Models	<b>19</b>

### Support Bars

Choose the appropriate kit for HWBI or HWB series

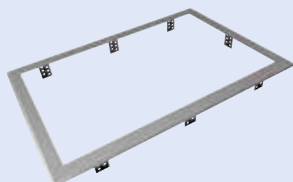

**HWB-FUL-MNT**  
Choose the appropriate kit for HWB-FUL, HWB-43 or HWB-4Q, -7Q, -11Q series



**HWB-MNT-REC or HWB-MNT-RND**



**HWBI2MANIF**



**BALLVALVE1INCH**

### MOUNTING KITS – VALVES

**Necessary at your Well installation –**

<b>HWB-FUL-MNT</b>	Mounting Kit for combustible countertops for HWB-FUL series only	<b>\$ 98</b>
<b>HWB-43-MNT</b>	Mounting Kit for combustible countertops for HWB-43 series only	<b>117</b>
<b>HWB-4Q-MNT</b>	Mounting Kit for combustible countertops for HWB-4Q series only	<b>58</b>
<b>HWB-7Q-MNT</b>	Mounting Kit for combustible countertops for HWB-7Q series only	<b>64</b>
<b>HWB-11Q-MNT</b>	Mounting Kit for combustible countertops for HWB-11Q series only	<b>69</b>
<b>HWB-MNT-REC</b>	Kit allows mounting to thick countertops - 8 Brackets (HWBI and HWB Rectangular Heated Wells only)	<b>70</b>
<b>HWB-MNT-RND</b>	Kit allows mounting to thick countertops - 4 Brackets (Round Heated Wells only)	<b>35</b>

**External Manifold includes Individual Ball Valve for each Well (HWBI only, not available for the Slim models) –**

<b>HWBI2MANIF</b>	2-Pan Accessory	<b>689</b>
<b>HWBI3MANIF</b>	3-Pan Accessory	<b>978</b>
<b>HWBI4MANIF</b>	4-Pan Accessory	<b>1267</b>
<b>HWBI5MANIF</b>	5-Pan Accessory	<b>1556</b>
<b>HWBI6MANIF</b>	6-Pan Accessory	<b>1845</b>

**Necessary at your Well Installation –**

<b>BALLVALVE3/4</b>	High Temperature 3/4" NPT Ball Valve for units with Individual Drain(s) and no Manifold	<b>91</b>
<b>BALLVALVE1INCH</b>	High Temperature 1" NPT Ball Valve for units with Manifold Drain (Ganged Heated Wells only)	<b>70</b>
<b>GATEVALVE3/4IN</b>	High Temperature 3/4" NPT Gate Valve for units with Individual Drain(s) and no Manifold	<b>106</b>
<b>GATEVALVE1IN</b>	High Temperature 1" NPT Gate Valve for units with Manifold Drain (Ganged Heated Wells only)	<b>156</b>
<b>HWB-RDHV</b>	Heated Well Remote Handle for 3/4" Drains only and includes a Ball Valve	<b>361</b>



**GATEVALVE1INCH**

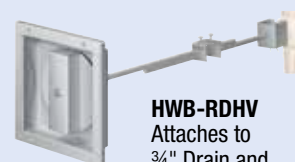

**HWB-RDHV**  
Attaches to 3/4" Drain and includes a Ball Valve



# Decorative Lamps & Display Lights

*Cafeterias • Convenience Stores  
Supermarkets & Delis • Restaurants & Cafes  
Clubs & Bars • Concessions*



**DL-1300-SR (DL-1200-SR in background)**  
in Clear Brushed Metal  
Gloss finish *pg. 39*



**DL-400-SN** in Glossy Gray  
Gloss finish *pg. 39*



**DL-500-SR** in Bright Brass  
Plated finish *pg. 39*



**DL-800-SR** in *Designer* color Warm Red  
*pg. 39*



**DL-725-RL** in Bright Nickel  
Plated finish *pg. 39*



**HL-54** (sneeze guards not available) *pg. 43*

**NEW**



**HL5-60** in Standard Clear Anodized finish (sneeze  
guards not available) *pg. 44*





Decorative Lamps & Display Lights

**ORDERING INSTRUCTIONS**

Luminaire lamps are for lighting only. LUMINAIRE option must be specified when lamps are utilized for decorative purposes only (no heating). This option is not field convertible. Maximum 100 watts.

**CLEARANCE REQUIREMENTS**

- NOTE:** Install 240V, 250W watt no closer than 25 mm from a sidewall and no closer than 406 mm above a combustible surface, or no closer than 127 mm to a non-combustible surface.
- NOTE:** Install HIGH WATT 240V, 375W bulb no closer than 25 mm from a sidewall and no closer than 686 mm above a combustible surface, or no closer than 127 mm to a non-combustible surface.
- NOTE:** Multiple installation of Decorative Lamps must have a minimum clearance of 305 mm on center of shade between each unit.

**Specify the following information with your order:**

1. **Electrical:** Voltage 240V single phase and Wattage 100W (Luminaire), 250W (Standard), or 375W (High) Watts
2. **Mounting Style Code:** A, C, P, R, S
3. **Switch Location Code:** Lower (L), None (N), Remote (R) or Upper (U). DLH models must have remote switch or none
4. **Shade Style Code:** -400, -500, -600, -700, -725, -750, -760, -775, -800, -1100, -1200, -1300, -1400, -1500
5. **Shade and Canopy Colors:**  
Warm Red, Black, Gray Granite, White Granite, Navy Blue, Hunter Green, Antique Copper, Smooth White, Gleaming Gold, Glossy Gray, Bold Black, Radiant Red\* (lampshade only), Brilliant Blue\* (lampshade only), Clear Coat Brushed Metal\* (lampshade only), Bright Brass\*, Bright Nickel\*, Bright Copper\*, Antique Nickel\*, Antique Brass\*, Antique Bronze\*
6. **Overall Unit Length:** For C or S Mounts, from ceiling to bottom of warmer lamp shade  
For A or P Mounts, from center of shade to wall plus vertical shade length
7. **Clearance:** From bulb to surface (see **NOTE** Clearance Requirements above)
8. **Accessory Bulb Color/Coating:**  
40W Clear Coated (Luminaire only)  
250W Clear Uncoated or Clear Coated
9. **Optional Cord Color:** Black (standard), White (optional)

\* Special process required and extended lead times, see page 41 for additional charge. Specify your appropriate accessories with your order.

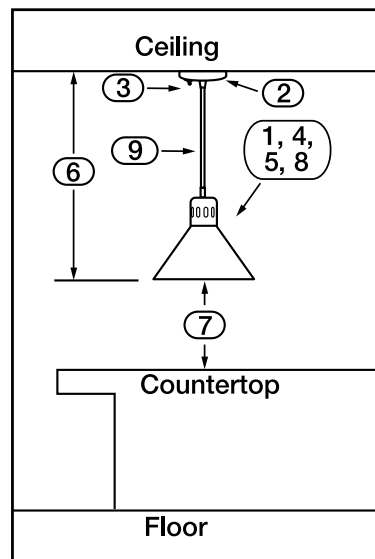

**DLx - xxx - xxx**

Decorative Lamp

No Character = Standard Watt  
L=Luminaire Low Watt  
H = High Wattage

Switch Location

Mounting Style

Shade Style

## Decorative Lamps/ Luminaires

Hatco Decorative Lamps provide radiant heat to briefly hold food warm at kitchen work areas, wait staff pickup stations or customer serving points, while enhancing your décor. Versatile enough for any location, the range of lights are available with a selection of personalized choices: shade styles, colors, switch locations and mounting arrangements. Configurations for lighting (Luminaire), as well as foodwarming, are available.

- Decorative Lamps and Luminaires available in fourteen shade styles
- Five different mounting arrangements to choose from
- Seven *Designer* colors, seven Gloss finishes and six Plated finishes available
- Four power switch options:
  - Upper (on canopy)
  - Lower (at stem)
  - Remote
  - None
- Available for food holding and display or lighting only applications
- Low and standard bulbs available in certain voltages, see accessories on page 42 (bulb not included in unit price)

Rigid Stem Mount in unit color (except for Gloss finishes Radiant Red, Brilliant Blue and Clear Brushed Metal)

Black cord is standard (white cord optional)  
Various cord lengths available, starting at 432 mm, while retractable can vary

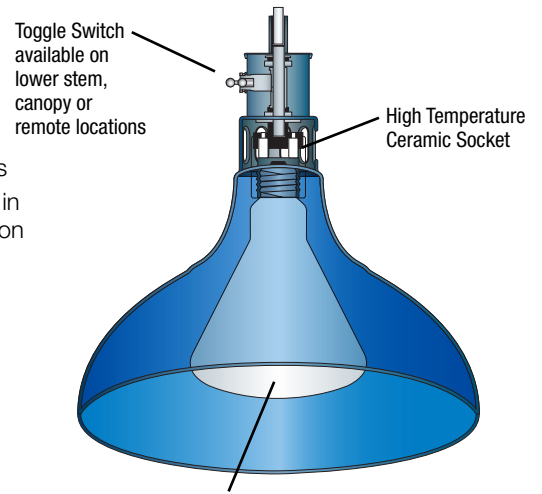

**NOTE:** Decorative Lamps and Luminaires are non-returnable.

## Build A Decorative Lamp

Hatco has given you a variety of simple and easy ways to "Build Your Decorative Lamp." You can go online or quickly do the work tables of "How to Build Your Lamp" on pages 39 through 41.

- GO online at: [www.hatcocorp.com](http://www.hatcocorp.com) and click on "Build a Lamp" under the resources Tab. (*Download a PDF of your lamp configuration in color and a Hatco List Price Quote*)
- OR follow the six steps in the Hatco Price List (next three pages) to build your Hatco model code and List Price. Then look at the following page for the accessories, like a bulb or track, to easily complete your total order.



Hatco Web Site shown, click on the Resources Tab and click on "Build A Lamp" configure your choices



Now you can develop your own Hatco Decorative Lamp solutions with our online lamp configurator.

Visit [www.hatcocorp.com](http://www.hatcocorp.com)  
Click on "Build a Lamp"

### HOW TO BUILD A LAMP

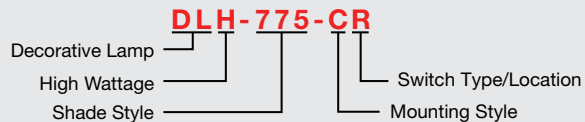

**Specify the following options when ordering:**

1 Electrical	<b>DLH</b>	(High Watt - 375 watt max)	<b>No Charge</b>
2 Mounting Style	<b>C</b>	(Cord Mount)	<b>No Charge</b>
3 Switch Location	<b>R</b>	(Remote Switch Location)	<b>No Charge</b>
4 Shade Style	<b>-775</b>	(See Shade Style on page 40)	<b>369</b>
5 Shade Color	<b>BBRASS</b>	(Bright Brass Plated Finish)	<b>154</b>
6 Overall Length	<b>2032 mm</b>	(Overall Length) - Only C mounts and over 1829 mm	<b>\$ 18</b>
			<b>TOTAL \$541</b>

(Specify to the nearest inch – CL, CU, PL, PU, SL, SU mounts only).

Information indicated in red are items that the customer must enter. *Bulbs are not included.*



## Build A Decorative Lamp Configurator Worksheet

Complete the six steps on this worksheet to configure your Hatco model code and List Price. In order to get exactly what you need in the least amount of time, have this handy when ordering your Hatco Decorative Lamp.



Decorative Lamps & Display Lights

**BUILD YOUR DECORATIVE/LUMINAIRE LAMPS – STEPS 1 AND 2**  
 (To determine your total list price and model code, pick all your options - bulb not included)

### STEP 1: ELECTRICAL

**Voltage** 240V (CE Mark available at no added charge) **No Charge**

**Wattage** **No Charge**

- DLL-** Luminaire 100 watt max
- DL-** Standard 250 watt max
- DLH-** High Watt 375 watt max

### STEP 2: MOUNTING STYLE

Mounting Style –

<b>A</b>	Arm	<b>\$ 62</b>
<b>P</b>	Pivot	<b>62</b>
<b>C</b>	Cord (specify Cord Color)	<b>No Charge</b>
<b>R</b>	Retractable (specify Cord Color)	<b>228</b>
<b>S</b>	Stem	<b>62</b>

MOUNTING STYLES		SPECIFY the:	Shade Height	
			216 mm	267 mm
<b>ARM</b>	<b>A Mount</b> Rigid Mount to canopy with pivot. 	Horizontal Stem Length	178 to 508 mm	
			Overall Length: 432 to 762 mm	Overall Length: 483 to 813 mm
<b>PIVOT</b>	<b>P Mount</b> Rigid Mount to canopy with pivot. 	Overall Length (from pivot to bottom of shade)	432 to 1803 mm	483 to 1854 mm
<b>CORD</b>	<b>C Mount</b> Cord Mount to canopy. 	Overall Length	432 mm to any length	483 mm to any length
<b>RETRACTABLE CORD</b>	<b>R Mount</b> Retractable Cord Mount. 	Adjusts to a maximum and minimum according to shade height	787 to 1765 mm	838 to 1816 mm
<b>STEM</b>	<b>S Mount</b> Rigid Stem Mount to canopy. 	Overall Length	356 to 1803 mm	406 to 1854 mm

Go to next page for Steps 3-4.

**NOTE:** Decorative Lamps and Luminaires are non-returnable.

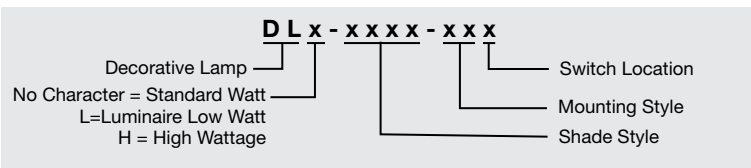

# Build A Decorative Lamp Configurator Worksheet

Continued from page 39



Decorative Lamps & Display Lights

**BUILD YOUR DECORATIVE/LUMINAIRE LAMPS – STEPS 3 AND 4**  
 (To determine your total list price and model code, pick all your options - bulb not included)

### SWITCH LOCATIONS

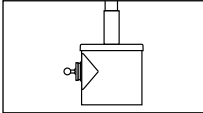

#### L - Lower Switch

Not available on:

- DLH (high watt models)
- A Mount

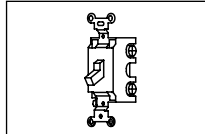

#### R - Remote Switch

- Accommodates 16 amps
- Up to seven 250W lamps, or five 375W lamps maximum per remote switch

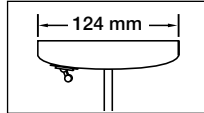

#### U - Upper Switch

Not available on:

- DLH (high watt models)
- R Mount

### STEP 3: SWITCH LOCATION

Switch Location –

No Charge

L	Lower (not available on high watt models)
N	None
R	Remote
U	Upper (not available on high watt models)

### SHADE STYLES (height and width shown)

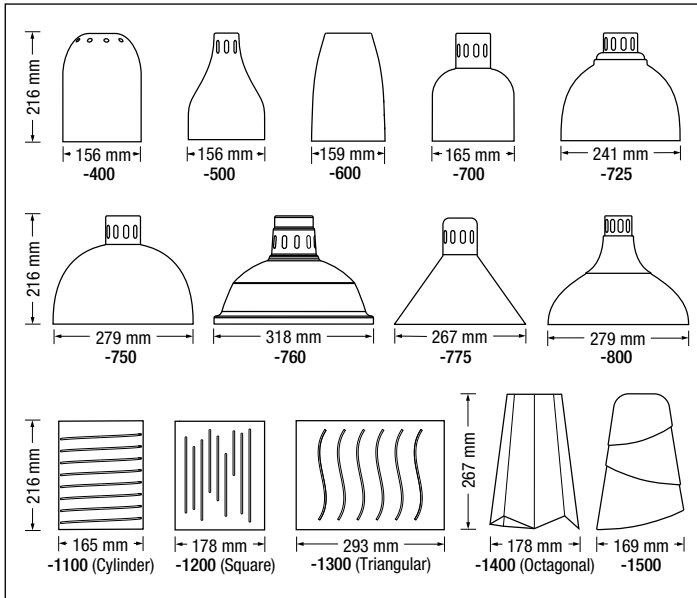

### STEP 4: SHADE STYLE

Shade Code

Ship Weight  
(depending on components)

List Price

-400	3-5 kg	\$338
-500	3-5 kg	338
-600	3-5 kg	338
-700	3-5 kg	338
-725	3-5 kg	\$369
-750	3-5 kg	369
-760	3-5 kg	369
-775	3-5 kg	369
-800	3-5 kg	369
-1100	3-5 kg	369
-1200	3-5 kg	369
-1300	3-5 kg	369
-1400	3-5 kg	369
-1500	3-5 kg	420

**Go to next page for Steps 5-6.**

**DLx - xxx - xxx**

No Character = Standard Watt  
 L=Luminaire Low Watt  
 H = High Wattage

Decorative Lamp

Switch Location

Mounting Style

Shade Style

**NOTE: Decorative Lamps and Luminaires are non-returnable.**





# Build A Decorative Lamp Configurator Worksheet

Continued from page 40

**BUILD YOUR DECORATIVE/LUMINAIRE LAMPS – STEPS 5 AND 6**  
 (To determine your total list price and model code, pick all your options - bulb not included)



Visit [www.hatcocorp.com](http://www.hatcocorp.com)  
 Click on "Build a Lamp"

Decorative Lamps & Display Lights

## STEP 5: SHADE AND CANOPY COLORS\*

### Shade and Canopy Colors –

*Designer Colors* **No Charge**

<b>RED</b> Warm Red	<b>NAVY</b> Navy Blue
<b>BLACK</b> Black	<b>GREEN</b> Hunter Green
<b>GRAY</b> Gray Granite	<b>COPPER</b> Antique Copper
<b>WHITE</b> White Granite	

*Gloss Finishes* **No Charge**

<b>SWHITE</b> Smooth White	<b>GGRAY</b> Glossy Gray
<b>GGOLD</b> Gleaming Gold	<b>BBLACK</b> Bold Black

\***Gloss Finishes for Shade Only** – (must choose other finish for remainder of unit) – **Special Process Required and Extended Lead Times** –

<b>RRED</b>	Radiant Red
<b>BBLUE</b>	Brilliant Blue
<b>CL-COAT</b>	Clear Brushed Metal

*Plated Finishes –*

**Special Process Required and Extended Lead Times –**

<b>BBRASS</b>	Bright Brass	<b>\$154</b>
<b>BNICKEL</b>	Bright Nickel	<b>154</b>
<b>BCOPPER</b>	Bright Copper	<b>154</b>
<b>ANICKEL</b>	Antique Nickel	<b>154</b>
<b>ABRASS</b>	Antique Brass	<b>154</b>
<b>ABRONZE</b>	Antique Bronze	<b>154</b>

## SHADE AND CANOPY COLORS

### Designer Colors



### Gloss Finishes



\***Gloss Finishes for Shade Only** – **Special Process Required and Extended Lead Times**



*Printed colors are a representation and may not exactly match our Designer, Gloss and Plated Finishes.*

### Plated Finishes – **Special Process Required and Extended Lead Times**



\***Exception: DL-1500 for Shade Only –**



\***Gloss and Plated Finishes** – **Special Process Required and Extended Lead Times**

## STEP 6: OVERALL LENGTH

**Overall Length** – For C Mounts from ceiling to bottom of lamp shade. For A or P Mounts, from center of shade to wall plus vertical shade length (specify exact length in whole numbers).

<b>Up to 1829 mm</b>	<b>No Charge</b>
<b>Greater than 1829 mm</b> (C mount only)	<b>\$18</b>

## YOUR TOTAL LIST PRICE AND MODEL CODE

Add the total costs of options below (not for retrofit – bulb not included) –

<b>Step 1</b>	Electrical	<b>\$ 0.00</b>
<b>Step 2</b>	Mounting Style	<input type="text"/>
<b>Step 3</b>	Switch Location	<b>0.00</b>
<b>Step 4</b>	Shade Style	<input type="text"/>
<b>Step 5</b>	Shade and Canopy Colors	<input type="text"/>
<b>Step 6</b>	Overall Length	<input type="text"/>
<b>Your Total Price</b>		<b>\$ <input type="text"/></b>

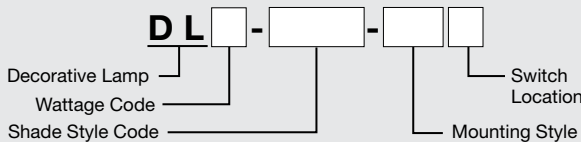

**NOTE: Decorative Lamps and Luminares are non-returnable.**

**BULBS AND ACCESSORIES – PAGE 42**

Decorative Lamps & Display Lights



**DL-750-RL** in Clear Brushed Metal shade finish and canopy unit in Designer Black

**OPTIONS** (available at time of purchase only)

**DL-CORD-WHITE** White Cord (C=Cord, R=Retractable Mounts Only) **No Charge**  
(Black is standard)

**Leads – For any SL, SR or SU Mount units, must specify Lead Length –**

<b>LEADS5</b>	305-1524 mm Extended Electrical Leads	<b>\$20</b>
<b>LEADS10</b>	1829-3048 mm Extended Electrical Leads	<b>40</b>
<b>LEADS15</b>	3353-4572 mm Extended Electrical Leads	<b>60</b>
<b>LEADS20</b>	4877-6096 mm Extended Electrical Leads	<b>80</b>

**ACCESSORIES** (available for purchase at any time)

<b>DL-SWITCH-16AMP</b>	16 Amp Lamp Toggle Switch	<b>each \$17</b>
<b>WHITE-CTD-240L</b>	240 Volt, 40 Watt Clear Bulb, Coated (Luminaire models only)	<b>each 11</b>
<b>WHITE-UCTD-240</b>	240 Volt, 250 Watt Clear Bulb, Uncoated	<b>each 52</b>
<b>WHITE-CTD-240</b>	240 Volt, 250 Watt Clear Bulb, Coated	<b>each 63</b>

**WHITE-CTD-240L**



**WHITE** uncoated



**WHITE** coated

**NOTE:** Decorative Lamps and Luminaires are non-returnable.



## Glo-Rite® Display Lights

Let the light shine on your work surface or display areas with Glo-Rite® Display Lights. Durable and effective, Hatco light strips are made of extruded aluminum housings with bright-annealed reflectors for maximum brightness.

- Extruded aluminum housings
- Incandescent bulbs with special protective coating to guard against food contamination
- Bright-annealed reflectors for maximum brightness
- Extra lamps available on models from 610 to 1829 mm
- Optional *Designer* colors: Warm Red, Black, Gray Granite, White Granite, Navy Blue, Hunter Green or Antique Copper



Decorative Lamps & Display Lights

### GLO-RITE DISPLAY LIGHTS

Model	Voltage		No. of Bulbs	Width	Watts	Ship Weight	List Price
	Single Phase						220, 240V†
HL-18	220 or 240		2	457 mm	120	3 kg	\$337
HL-24	220 or 240		2	610 mm	120	3 kg	355
HL-24-2	220 or 240		3	610 mm	180	3 kg	401
HL-30	220 or 240		2	762 mm	120	3 kg	373
HL-30-2	220 or 240		4	762 mm	240	4 kg	440
HL-36	220 or 240		3	914 mm	180	4 kg	425
HL-36-2	220 or 240		5	914 mm	300	4 kg	497
HL-42	220 or 240		3	1067 mm	180	5 kg	443
HL-42-2	220 or 240		6	1067 mm	360	5 kg	536
HL-48	220 or 240		4	1219 mm	240	5 kg	495
HL-48-2	220 or 240		7	1219 mm	420	5 kg	594
HL-54	220 or 240		4	1372 mm	240	5 kg	514
HL-54-2	220 or 240		8	1372 mm	480	6 kg	633
HL-60	220 or 240		5	1524 mm	300	6 kg	565
HL-60-2	220 or 240		9	1524 mm	540	6 kg	691
HL-66	220 or 240		5	1676 mm	300	6 kg	622
HL-66-2	220 or 240		10	1676 mm	600	7 kg	772
HL-72	220 or 240		6	1829 mm	360	7 kg	675
HL-72-2	220 or 240		10	1829 mm	600	10 kg	829

HL-24-2 including extra lamp assembly with lamps on 305 mm centers standard

† CE Mark available at no added charge.

**All Display Light Models Feature:**

Toggle Switch (max. 15 amps) Location: Chef's left side (unless otherwise specified).

Leads: 152 mm leads – server's right.

Dimensions: 76 D x 64 H mm.

#### OPTIONS (available at time of purchase only)

NO BULB	No Bulb	No Charge
REM TOG	Remote Toggle Switch (max. 15 Amps)	No Charge
<b>Leads – Must specify Lead Length –</b>		
LEADS5	305-1525 mm Extended Electrical Leads	\$20
LEADS10	1829-3048 mm Extended Electrical Leads	40
LEADS15	3352-4572 mm Extended Electrical Leads	60
LEADS20	4877-6096 mm Extended Electrical Leads	80

#### ACCESSORIES (available for purchase at any time)

HL-BRKT	Adjustable Angle Bracket	pair \$24
<b>LED Bulbs (230V) –</b>		
CLED-2700-230	Chef LED Bulb (emulates incandescent)	each \$101
CLED-3000-230	Chef LED Bulb (emulates halogen)	each 101
CLED-4000-230	Chef LED Bulb (emulates fluorescent)	each 101

#### OPTIONS (available at time of purchase only)

Designer Colors – Non-standard colors are non-returnable –

RED	Warm Red	per 305 mm	\$25
BLACK	Black	per 305 mm	25
GRAY	Gray Granite	per 305 mm	25
WHITE	White Granite	per 305 mm	25
NAVY	Navy Blue	per 305 mm	25
GREEN	Hunter Green	per 305 mm	25
COPPER	Antique Copper	per 305 mm	25

HL-BRKT Accessory



CLED-2700, -3000 or -4000 Accessory

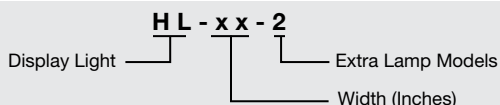

**COLORS AND FINISHES – INSIDE BACK COVER**

## Glo-Rite® Curved Display Lights

A stylish choice for illuminating your serving area. The Glo-Rite® Curved Display Light offers the highest light output that is ideal for illuminating food products with either a warm white light (3050K) or a cool or neutral white light (4100K).

The sleek, curved design is patented and the LED lighting delivers significant savings with lower energy consumption and greater reliability. Hatco provides you with a wide variety of colors and lengths for any serving area.

- Features a patented curved housing design with energy efficient dual LED lights across the display lamp that provide longer performance and energy savings (compared to standard incandescent bulbs)
- Lengths available from 457-1829 mm in 152 mm increments
- Field replaceable dual LED lights
- Matches the Hatco line of Glo-Ray® Curved Infrared Strip Heaters for a fully integrated look
- Angle brackets and 152 mm LED leads are standard
- Optional non-adjustable tubular stands and top or bottom mounting stands available



**HL5-36**  
Clear Anodized (standard) shown in top and underside views



### GLO-RITE® CURVED DISPLAY LIGHTS

Model	Standard Watt	Width	Voltage	Watts	Ship Weight*	List Price†
HL5-18		457 mm	220 or 240	4.3	4 kg	\$ 883
HL5-24		610 mm	220 or 240	5.9	6 kg	964
HL5-30		762 mm	220 or 240	7.6	6 kg	1045
HL5-36		914 mm	220 or 240	9.2	6 kg	1126
HL5-42		1067 mm	220 or 240	10.8	6 kg	1207
HL5-48		1219 mm	220 or 240	12.4	7 kg	1288
HL5-54		1372 mm	220 or 240	14.0	8 kg	1369
HL5-60		1524 mm	220 or 240	15.7	8 kg	1450
HL5-66		1676 mm	220 or 240	17.3	9 kg	1531
HL5-72		1829 mm	220 or 240	18.9	9 kg	1612

† CE Mark available at no added charge.

\* Weights do not include shipping materials.

**All Curved Display Light Models Feature:**

Voltage: 220-240, single phase.

Models Shipped with: End panels, angle brackets with rocker switch under unit on power side.

Leads: 152 mm leads - on power side.

Dimensions: 457 mm-1829 mm W x 152 mm D x 77 mm H (height includes standard angle bracket).

#### OPTIONS (available at time of purchase only)

**Designer Colors – Non-standard colors are non-returnable – Clear Anodized Standard –**

RED	Warm Red	per 305 mm	\$25
BLACK	Black	per 305 mm	25
GRAY	Gray Granite	per 305 mm	25
WHITE	White Granite	per 305 mm	25
NAVY	Navy Blue	per 305 mm	25
GREEN	Hunter Green	per 305 mm	25
COPPER	Antique Copper	per 305 mm	25

**Gloss Finishes – Non-standard colors are non-returnable –**

GGOLD	Gleaming Gold	per 305 mm	34
GGRAY	Glossy Gray	per 305 mm	34
BBLACK	Bold Black	per 305 mm	34
RRED	Radiant Red	per 305 mm	34
BBLUE	Brilliant Blue	per 305 mm	34

**LED Light –**

HL5-3050	Warm White (3050K)	Standard
	Cool or	
HL5-4100	Neutral White (4100K)	No Charge

#### OPTIONS (available at time of purchase only)

**LED Leads (must specify LED Lead Length) –**

HL5-LEAD5	1524 mm total LED Lead Length (includes a 914 mm conduit)	\$30
HL5-LEAD6	1829 mm total LED Lead Length (includes a 914 mm conduit)	37
HL5-LEAD7	2134 mm total LED Lead Length (includes a 914 mm conduit)	44
HL5-LEAD8	2438 mm total LED Lead Length (includes a 914 mm conduit)	51
HL5-LEAD9	2743 mm total LED Lead Length (includes a 914 mm conduit)	58
HL5-LEAD10	3048 mm total LED Lead Length (includes a 914 mm conduit)	65
HL5-CORD	1829 mm Cord with Plug (Schuko 777, BS-1363)	28

**Non-Adjustable Tubular Stands –**

**Clear Anodized Standard – Bottom Mount Leg –**

NTL5-10, -12	Bottom mount installation (specify 254 mm or 305 mm clearance)	1 pair	\$130
NTL5-14, -16	Bottom mount installation (specify 356 mm or 406 mm clearance)	1 pair	163

**Side Mount Leg –**

SNTL5-10T, -12T	Top mount installation (specify 254 mm or 305 mm clearance)	\$175
SNTL5-14T, -16T	Top mount installation (specify 356 mm or 406 mm clearance)	200
SNTL5-10B, -12B	Bottom mount installation (specify 254 mm or 305 mm clearance)	175
SNTL5-14B, -16B	Bottom mount installation (specify 356 mm or 406 mm clearance)	200

*Designer color or Gloss Finish for Non-Adjustable Tubular Stands –*

NTL5-PAINT	Non-standard colors are non-returnable –	1 pair	36
------------	--	--------	----

HL5 - x x

Glo-Rite Curved Display Light Aluminum Housing Width (Inches)

**COLORS AND FINISHES – INSIDE BACK COVER**





Save money lighting your  
Hatco Glo-Ray® Strip Heater



# GREEN ENERGY



Commit to going green in your foodservice operation with Hatco's patented Chef LED Bulbs! Heat strengthened glass lens protects the Light Emitting Diode (LED) while the exterior is made of rugged aluminum and prevents breakage of the components due to incidental contact in a busy kitchen environment. A Chef LED Bulb has substantial benefits and energy savings over other bulbs and are directional.

Other features include:

- Average of 184% increased light output, based on Foot Candle average delivered to surface from a height of 12" vs. 40 watt incandescent bulb
- Up to 91% energy savings vs. 40 watt incandescent bulb
- Unique design allows operation over a steam table
- 120V or 230V (50-60 Hz) offerings
- Warranted for one year

Go to [www.hatcocorp.com](http://www.hatcocorp.com) and download the LED Cost Savings & Energy Analysis calculator to review your energy savings potential.

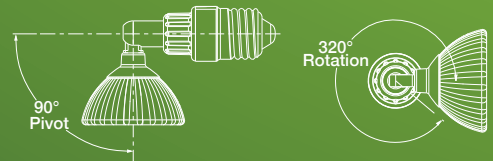

Scan to see how easy it is to install the Chef LED bulb, and direct the light, in your foodwarmer.



**CLED-2700**  
**(Warm Light)**

3.5 watt

25,000 Hours\*

Closest kelvin  
Incandescent



**CLED-3000**  
**(Warm Light)**

3.5 watt

25,000 Hours\*

Closest kelvin  
Halogen



**CLED-4000**  
**(Cool Light)**

3.5 watt

25,000 Hours\*

Closest kelvin  
Fluorescent Tube

**BULB:**  
**Halogen**

60 watt

1,500 Hours

**BULB:**  
**Incandescent\***

40 watt

3,000 Hours

\*Appliance bulb

\* With 167°F ambient air temperature.

Used in HL, GRAL, GRAHL, GRAL-XXD, GRAIHL, GR2AL, GR2AHL and GR2AL-XXD Models, see accessories. Please contact factory for the most up-to-date listing of models that can use Chef LED Bulbs.

# Strip Heaters

*Cafeterias • Buffets • Supermarkets & Delis  
Restaurants & Cafés • Clubs & Bars*



**GR5AL** model in optional Radiant Red above a **GRS-54** *pg. 50*



**GRA-36D** *pg. 42*



**GRAH-42D** with optional 152 mm spacer and optional non-adjustable tubular stands *pg. 55*



**GRAL-72D** with optional non-adjustable tubular stands *pg. 56*



**GRAHL-96D** with optional *Designer Color* and non-adjustable tubular stands *pg. 56*



**GRNH-48** with Standard angle brackets and optional *Designer Color* (Sneeze Guards as shown not available) *pg. 58*



**GRAIHL-48** requires Remote Control Enclosure (RMB) *pg. 60*



**GR2AHL-84** with optional *Designer Color* housing and Sneeze Guards *pg. 64*



**UGA-42D** in optional Radiant Red *Designer Color* housing *pg. 70*



**Ordering Instructions – Watch How To Order A Hatco Strip Heater on Hatco's website under Resources, Video Library**

**QUICK GUIDE – FOR ANY CLEARANCE – Detailed mounting and spacing requirements found on page 72**

**NARROW CLEARANCE  
Infra-Black®**

- Provides a very even and thermostatically controlled heat source
- For applications where the distance from the heat source to the target is narrow

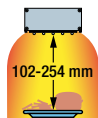

**STANDARD CLEARANCE  
Infrared Metal Sheathed Element:**

- Pre-focused heat pattern directs infrared heat to the holding area
- Uniform heat distribution
- Energy efficient
- A wide variety of sizes and features available
- Our most popular solution

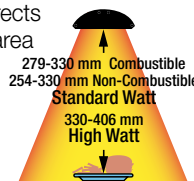

**HIGH CLEARANCE  
Ultra-Glo® Durable Ceramic Element**

- Stronger, more intense heat source
- For applications where there is a greater distance between the heat source and target surface
- Ideal for French fry station applications

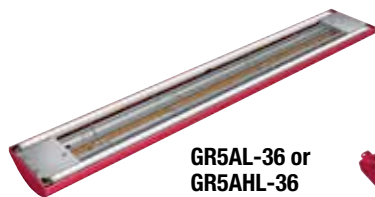
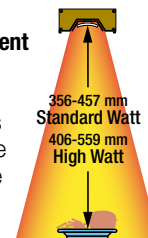

**GR5AL-36 or  
GR5AHL-36**



**GR5A-36 or  
GR5AH-36**

**Glo-Ray® Curved Infrared Strip Heaters:** (pages 49-51)

1. Choose a length
2. Standard or high watt
3. Lights or no lights
4. Voltage: 220-230, 230-240
5. Choose control option for GR5A and GR5AH (GR5AL, GR5AHL have Remote Control Enclosure included)



**GRA-72 or  
GRAH-72**



**GRA-72D or  
GRAH-72D**



**GRAL-72 or  
GRAHL-72**



**GRAL-72D or  
GRAHL-72D**

**Glo-Ray® Infrared Metal-Sheathed Strip Heaters:** (pages 42-47)

1. Choose a length
2. Single or dual warmer
3. Standard or high watt
4. Lights or no lights
5. Voltage: 220, 240
6. Choose control option, remote installation recommended (required on some models)



**GR-36 or  
GRH-36**

**Glo-Ray® Infrared Stainless Steel Strip Heaters:** (pages 53-54)

1. Choose a length
2. Standard or high watt
3. Voltage: 220, 240, 220-230, 230-240
4. Choose control option, remote installation is recommended. Multiple Strip Heaters may be connected to one RMB2 if the combined current draw of the warmers is less than the rating for the RMB2. Control wires exit from the attached control box. If no control box is supplied, they exit from side of the unit.



**GRN-24  
GRNH-24**

**Glo-Ray® Narrow Infrared Strip Heaters:** (page 48-59)

1. Choose a length
2. Standard or high watt
3. Voltage: 220 or 240
4. Choose control option, remote installation is recommended. Multiple Strip Heaters may be connected to one RMB2 if the combined current draw of the warmers is less than the rating for the RMB2. Control wires exit from the attached control box. If no control box is supplied, they exit from side of the unit.

Strip Heaters

**Ordering Instructions *continued***

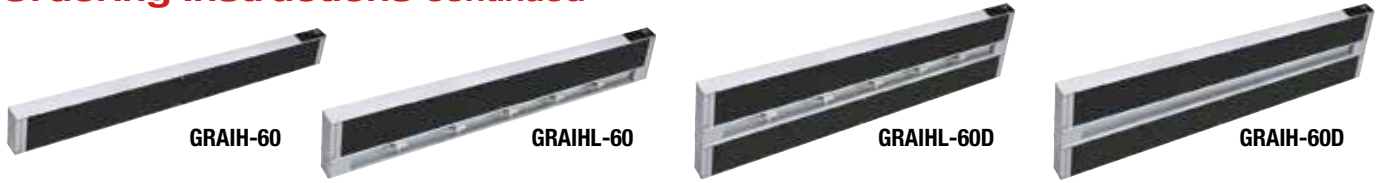

**Glo-Ray® Infra-Black® Strip Heaters:** (pages 50-52)

1. Choose a length
2. Single or dual warmer
3. Lights or no lights
4. Voltage: 220, 240
5. Choose control option, remote installation is recommended. Multiple Strip Heaters may be connected to one RMB2 if the combined current draw of

the warmers is less than the rating for the RMB2. Control wires exit from the attached control box. If no control box is supplied, they exit from side of the unit.

Strip Heaters



**Glo-Ray® Designer Infrared Strip Heaters:** (pages 63-68)

1. Choose a length
2. Single or dual warmer
3. Standard or high watt
4. Lights or no lights
5. Voltage: 220, 240
6. Choose control option, remote installation only Multiple Strip Heaters may be connected to one RMB2 if the combined current draw of the warmers is less than the rating for the RMB2.

Control wires exit from the attached control box. If no control box is supplied, they exit from side of the unit.

7. Choose inset panel and corner cap color
8. Select Non-adjustable Stand Length (optional Overhead Mount shown)



**Ultra-Glo® Ceramic Strip Heaters:** (pages 69-71)

1. Choose a length
2. Single or dual warmer
3. Standard or high watt
4. Lights or no lights
5. Voltage: 220, 240
6. Choose control option, remote installation is recommended Multiple Strip Heaters may be connected to one RMB2 if the combined current

draw of the warmers is less than the rating for the RMB2. Control wires exit from the attached control box. If no control box is supplied, they exit from side of the unit.

**Power and Switch Location**

Each Strip Heater has specific Power and Switch locations (sample below). For information on other models, visit the *Document Library* under *Resources* on [hatcocorp.com](http://hatcocorp.com), and search *Power Locations*.

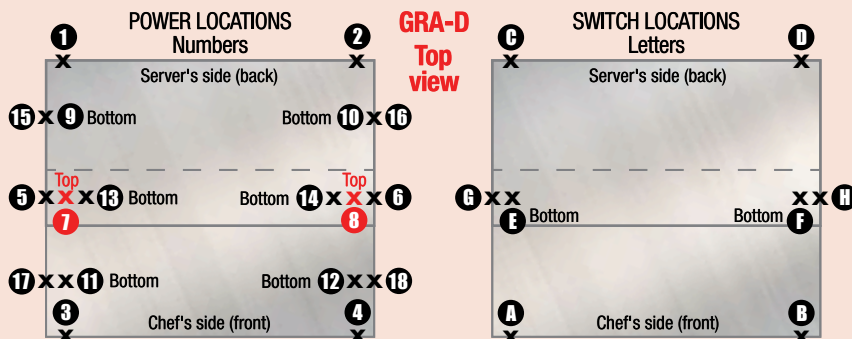

**POWER:** Numbers indicate potential power locations. Locations 9, 10, 11 and 12 are on the bottom of the warmer and are intended to be used in conjunction with the optional legs supplied by Hatco. Note: Maximum of 3 circuits down the leg. **SWITCH:** Letters indicate the potential control locations.

**NOTE:** Remote controls are available and recommended.

**Typical Conduit Connection**

**Glo-Ray® Strip Heaters and Narrow Strip Heaters** have Standard 152 mm leads, no conduit. **GR2A** models - conduit exits non-adjustable stand or overhead mount only. **GR5AL** models have a 1524 mm leadwire, which is 610 mm past the 914 mm conduit. **Ultra Glo®** models - conduit exits through attached control box; if no control box, conduit exits side of unit.





## Glo-Ray® Curved Infrared Strip Heaters

This stylish, patented design, based on our signature Glo-Ray Strip Heaters, is the perfect solution for your front-of-the-house applications. Superb for buffet and serving lines, the sleek curved design minimizes its size while accenting and warming the products below.

The entire holding surface is heated evenly with no "cold" spots thanks to Hatco's dependable infrared element technology.

- Narrow, curved design uses a very small footprint: 51 mm H x 153 mm D
- Lengths available from 457 - 1829 mm in 153 mm increments
- Patented housing design
- Angle brackets (mounting) are Standard
- Pre-focused heat maintains safe serving temperatures longer without continuing to cook the food
- Available in standard or high watt
- End panels and mounting brackets match unit color
- Hatco's wide array of colors help provide the right look for your venue



**GR5A-36/GR5AH-36**  
in optional Brilliant Blue Gloss Finish with Standard Angle Brackets

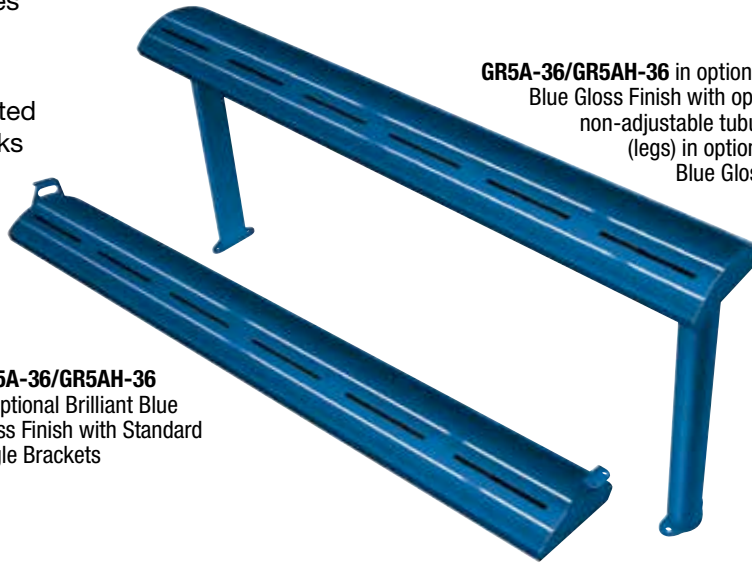

**GR5A-36/GR5AH-36** in optional Brilliant Blue Gloss Finish with optional 407 mm non-adjustable tubular stands (legs) in optional Brilliant Blue Gloss Finish

Strip Heaters

### GLO-RAY CURVED INFRARED STRIP HEATERS

Model#	Width	Watts		Approx. Weight	List Price
		220-230V <sup>E</sup>	230-240V <sup>EE</sup>		
<b>Standard Watt</b>					
GR5A-18	457 mm	250-273	230-250	8 kg	\$567
GR5A-24	610 mm	350-383	321-350	8 kg	607
GR5A-30	762 mm	450-492	413-450	9 kg	647
GR5A-36	914 mm	575-628	528-575	10 kg	687
GR5A-42	1067 mm	675-738	620-675	10 kg	727
GR5A-48	1219 mm	800-874	735-800	11 kg	768
GR5A-54	1372 mm	925-1011	850-925	12 kg	809
GR5A-60	1524 mm	1050-1148	964-1050	13 kg	850
GR5A-66	1676 mm	1160-1268	1065-1160	15 kg	891
GR5A-72	1829 mm	1275-1394	1171-1275	15 kg	932
<b>High Watt</b>					
GR5AH-18	457 mm	350-383	321-350	8 kg	\$575
GR5AH-24	610 mm	500-546	459-500	8 kg	615
GR5AH-30	762 mm	650-710	597-650	9 kg	655
GR5AH-36	914 mm	800-874	735-800	10 kg	695
GR5AH-42	1067 mm	950-1038	872-950	10 kg	735
GR5AH-48	1219 mm	1100-1202	1010-1100	11 kg	776
GR5AH-54	1372 mm	1250-1366	1148-1250	12 kg	817
GR5AH-60	1524 mm	1400-1530	1286-1400	13 kg	858
GR5AH-66	1676 mm	1560-1705	1433-1560	15 kg	899
GR5AH-72	1829 mm	1725-1885	1584-1725	15 kg	940

\* Available with CE Mark.

<sup>E</sup> Uses 220V element. <sup>EE</sup> Uses 240V element.

○ Does not include Remote Control Enclosure (RMB), see manual.

#### All Glo-Ray Curved Infrared Models Feature:

**Leads:** 915 mm conduit, 1524 mm Power Leads.

**Angle Brackets:** Provides 25 mm clearance between Strip Heater and oversheif.

**Dimensions:** 457-1829 mm W x 153 mm D x 51 mm H.

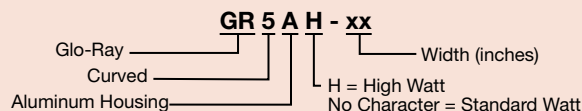

### OPTIONS (available at time of purchase only)

#### Designer Colors – Clear Anodized Standard –

End panels and Angle Brackets match unit color –

Non-standard colors are non-returnable –

RED	Warm Red	BLACK	Black	per 305 mm \$25
GRAY	Gray Granite	WHITE	White Granite	
BLUE	Navy Blue	GREEN	Hunter Green	
COPPER	Antique Copper			

#### Gloss Finishes – End panels and Angle Brackets match unit color –

Non-standard colors are non-returnable –

GGOLD	Gleaming Gold	RRED	Radiant Red	per 305 mm \$34
GGRAY	Glossy Gray	BBLUE	Brilliant Blue	
RBLACK	Bold Black			

REM INF Remote Infinite Switches in lieu of Toggle (max. 12.2 Amps) each 37

REM TOG Remote Toggle Switches (max. 15 Amps) No Charge

RMB Remote Control Enclosure (available in Designer Colors or Gloss Finishes) Non-standard colors are non-returnable – Please see manual for more information

#### Non-Adjustable Tubular Stands (Clear Anodized Standard) –

Bottom Mount - attach to counter

NTL5-10, -12	Specify 254 or 305 mm clearance	1 pair	\$129
NTL5-14, -16	Specify 356 or 407 mm clearance	1 pair	162

Side mount leg for bottom mount installation

SNTL5-10B, -12B	Specify 254 or 305 mm clearance	1 pair	175
SNTL5-14B, -16B	Specify 356 or 406 mm clearance	1 pair	200

Side mount leg for top mount installation

SNTL5-10T, -12T	Specify 254 or 305 mm clearance	1 pair	175
SNTL5-14T, -16T	Specify 356 or 406 mm clearance	1 pair	200

NTL5-PAINT Designer Color or Gloss Finish for Non-Adjustable Tubular Stands – Non-standard colors are non-returnable –

1 pair 36

#### Power Wire Leads – 1524 mm Power Lead length Standard –

GR5A-LEADS10	1829-3048 mm total Power Lead length	\$20
GR5A-LEADS15	3353-4572 mm total Power Lead length	40

**COLORS AND FINISHES – INSIDE BACK COVER**  
**RECOMMENDED MOUNTING HEIGHTS – PAGE 72**

## Glo-Ray® Curved Infrared Strip Heaters with LED Lights

Hatco's Glo-Ray Curved Infrared Strip Heaters with LED Lights feature a patented housing design that is low-profile, elliptical-shaped and stylish, the ideal solution for front-of-the-house applications where heat and/or lights are needed.

It can operate with just the dual LED lights; or the dual LED lights can be used simultaneously with the infrared emitter to provide the perfect balance of light and heat.

- Narrow, curved design: 51 H x 153 mm D uses a very small footprint with lengths available from 457-1829 mm in 153 mm increments
- Patented housing design has energy efficient dual LED lights across the entire strip heater, which provide longer performance and energy savings (compared to Standard incandescent bulbs, 3.5 to 15.2 watts based on length)
- Can be used with lights or heat only
- Angle brackets (mounting) are Standard
- Pre-focused heat maintains safe serving temperatures longer without continuing to cook the food
- 100% linear infinite controls with adjustability from 0-100%, allow for precise settings
- Field replaceable LED available as:
  - Warm White\* (Standard)
  - Neutral (Cool) White\*
  - Dual Color: Warm White/Neutral (Cool) White\* (toggle between color temperatures to enhance foods displayed)
- Electronic Infinite Remote Control Enclosure and power On/Off switch (controls lights, heat) included



**GR5AL-36/GR5AHL-36**  
Top and bottom view. Shown in optional Radiant Red Gloss Finish and Standard Angle Brackets

Strip Heaters

### GLO-RAY CURVED INFRARED STRIP HEATERS with LED LIGHTS

Model#	Width	Watts		Approx. Weight	List Price
		220-230V <sup>E</sup>	230-240V <sup>EE</sup>		
<b>Standard Watt</b>					
GR5AL-18	457 mm	254-278	234-254	8 kg	\$1884
GR5AL-24	610 mm	356-388	327-356	8 kg	1992
GR5AL-30	762 mm	458-499	421-458	9 kg	2100
GR5AL-36	914 mm	584-638	537-584	10 kg	2208
GR5AL-42	1067 mm	686-749	631-686	10 kg	2316
GR5AL-48	1219 mm	812-887	747-812	11 kg	2424
GR5AL-54	1372 mm	939-1025	864-939	12 kg	2532
GR5AL-60	1524 mm	1066-1163	980-1066	13 kg	2640
GR5AL-66	1676 mm	1177-1285	1083-1177	15 kg	2748
GR5AL-72	1829 mm	1294-1412	1190-1294	15 kg	2856
<b>High Watt</b>					
GR5AHL-18	457 mm	354-387	326-354	8 kg	\$1892
GR5AHL-24	610 mm	506-552	465-506	8 kg	2000
GR5AHL-30	762 mm	668-729	614-668	9 kg	2108
GR5AHL-36	914 mm	809-884	744-809	10 kg	2216
GR5AHL-42	1067 mm	961-1049	883-961	10 kg	2324
GR5AHL-48	1219 mm	1112-1215	1023-1112	11 kg	2432
GR5AHL-54	1372 mm	1264-1380	1162-1264	12 kg	2540
GR5AHL-60	1524 mm	1416-1546	1301-1416	13 kg	2648
GR5AHL-66	1676 mm	1577-1722	1450-1577	15 kg	2756
GR5AHL-72	1829 mm	1744-1904	1603-1744	15 kg	2864

\* Available with CE Mark.

<sup>E</sup> Uses 220V element. <sup>EE</sup> Uses 240V element.

**All Glo-Ray Curved Infrared with Infrared Lights Models Feature:**

**Switch Location:** Remote Control Enclosure with Electronic Infinite Control and power On/Off switch (controls lights and heat) included.

**Leads:** 914 mm conduit, 1524 mm Power Leads, 1981 mm LED Leads.

Standard LED lead length is 457 mm longer than Power Lead length.

**Angle Brackets:** Provides 25 mm clearance between strip heater and overself.

**Dimensions:** 457-1829 mm W x 153 mm D x 51 mm H.

**Control Box Dimensions:** 180 W x 140 mm H.

**Cut Out Dim.:** 257 W x 159 D x 121 mm H.

**OPTIONS - PAGE 51**

\* Warm White can range from 2700-3200K, Neutral (Cool) White from 4000-4300K

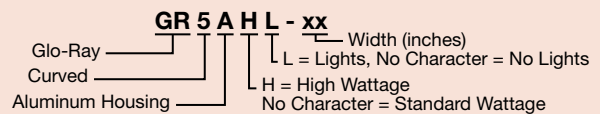



A GR5AL model in optional Radiant Red above a GRS-54

Strip Heaters

**OPTIONS** (available at time of purchase only)

**Designer Colors – End panels and Angle Brackets match unit color –**

**Non-standard colors are non-returnable – Clear Anodized Standard –**

<b>RED</b>	Warm Red	<b>BLACK</b>	Black	<b>GRAY</b>	Gray Granite	<b>COPPER</b>	Antique Copper	<b>per 305 mm 25</b>
<b>WHITE</b>	White Granite	<b>BLUE</b>	Navy Blue	<b>GREEN</b>	Hunter Green			

**Gloss Finishes – End panels and Angle Brackets match unit color – Non-standard colors are non-returnable –**

<b>GGOLD</b>	Gleaming Gold	<b>RRED</b>	Radiant Red	<b>GGRAY</b>	Glossy Gray			<b>per 305 mm 34</b>
<b>BBLUE</b>	Brilliant Blue	<b>BBLACK</b>	Bold Black					

**Non-Adjustable Tubular Stands – Clear Anodized Standard –**

**Bottom mount leg for bottom mount installation**

<b>NTL5-10, -12</b>	Specify 254 or 305 mm clearance	<b>1 pair 129</b>
<b>NTL5-14, -16</b>	Specify 356 or 406 mm clearance	<b>1 pair 162</b>

**Side mount leg for bottom mount installation**

<b>SNTL5-10B, -12B</b>	Specify 254 or 305 mm clearance	<b>1 pair 175</b>
<b>SNTL5-14B, -16B</b>	Specify 356 or 406 mm clearance	<b>1 pair 200</b>

**Side mount leg for top mount installation**

<b>SNTL5-10T, -12T</b>	Specify 254 or 305 mm clearance	<b>1 pair 175</b>
<b>SNTL5-14T, -16T</b>	Specify 356 or 406 mm clearance	<b>1 pair 200</b>

**NTL5-PAINT** Designer Color or Gloss Finish for Non-Adjustable Tubular Stands – Non-standard colors are non-returnable –

**1 pair 36**

**GR5AL-NW** Neutral (Cool) White LED\* **No Charge**

**GR5AL-WW/NW** Dual Warm/Neutral (Cool) White LED\* **\$268**

**GR5AL-OPP** Power and LED wiring exit opposite ends of unit (Same end is the Standard offering) – Must specify Power Lead length and LED Lead length required – **No Charge**

**Power Wire Leads – 1524 mm Power Lead length is Standard –**

<b>GR5AL-LEADS10</b>	1829-3048 mm total power Lead length	<b>\$20</b>
<b>GR5AL-LEADS15</b>	3353-4572 mm total power Lead length	<b>40</b>

**LED Leads - 1981 mm LED Lead length is Standard – Standard LED lead length is 457 mm longer than Power Lead length**

<b>LED-LEADS10</b>	3505 mm total LED Lead length	<b>\$32</b>
<b>LED-LEADS15</b>	5029 mm total LED Lead length	<b>64</b>
<b>LED-LEADS20</b>	6553 mm total LED Lead length	<b>96</b>

**COLORS AND FINISHES – INSIDE BACK COVER**  
**RECOMMENDED MOUNTING HEIGHTS – PAGE 72**

**RECOMMENDED LIGHT USAGE**

GR5A(H)L above...	Warm White*	Cool White*	Warm/Neutral (Cool) White*
Heated Well(s)	X		
Refrigerated Well(s)		X	
Heated Shelf (Shelves)	X		
Refrigerated Shelf (Shelves)		X	
Hot/Cold Well(s)			X
Hot/ Cold Shelf (Shelves)			X

\* Warm White can range from 2700-3200K, Neutral (Cool) White from 4000-4300K

## Glo-Ray® Aluminum Infrared Strip Heaters

Safely hold the temperature of your product without drying out or further cooking food with Hatco's Glo-Ray Aluminum Infrared Strip Heaters. The end result is hot, fresh food that's ready-to-serve. The continuous aluminum housing and heavy-duty mountings ensure the durability and quality of Hatco products. Heavy-duty stainless steel housings are available (see next page).

- Ensures maximum flavor, safety and holding time
- Even heat distribution – no "cold spots"
- Sturdy extruded aluminum housings do not sag, from 457 to 3658 mm
- Available in stainless steel housing 457 to 2438 mm
- Reflector does not blacken, maintaining a consistent heat pattern
- Heavy-duty insulation minimizes heat loss
- Protective reinforced wire guard supports heating element without affecting heat distribution
- Optional Sneeze Guards (excludes stainless steel models)
- Available with shatter-resistant incandescent lights (not available for stainless steel models)
- Additional reflector styles and lower wattage elements available, consult factory for more information

Strip Heaters

**Toggle Switch:** Max. 15 Amps  
**Infinite Switch:** Max. 12.2 Amps

### GLO-RAY ALUMINUM INFRARED STRIP HEATERS

Model	Width	Watts	Ship Weight	List Price <sup>○†</sup>
<b>Standard Watt</b>				
GRA-18	457 mm	250	3 kg	\$260
GRA-24	610 mm	350	3 kg	274
GRA-30	762 mm	450	4 kg	293
GRA-36	914 mm	575	4 kg	310
GRA-42	1067 mm	675	5 kg	330
GRA-48	1219 mm	800	5 kg	348
GRA-54	1372 mm	925	6 kg	371
GRA-60	1524 mm	1050	6 kg	396
GRA-66	1676 mm	1160	7 kg	436
GRA-72	1829 mm	1275	8 kg	491
GRA-84	2134 mm	1500	9 kg	567
GRA-96	2438 mm	1725	10 kg	646
GRA-108	2743 mm	1850	10 kg	811
GRA-120	3048 mm	2100	12 kg	880
GRA-132	3353 mm	2320	14 kg	951
GRA-144	3658 mm	2550	15 kg	1023
<b>High Watt</b>				
GRAH-18	457 mm	350	3 kg	\$268
GRAH-24	610 mm	500	4 kg	282
GRAH-30	762 mm	660	4 kg	301
GRAH-36	914 mm	800	4 kg	318
GRAH-42	1067 mm	950	5 kg	338
GRAH-48	1219 mm	1100	5 kg	356
GRAH-54	1372 mm	1250	6 kg	379
GRAH-60	1524 mm	1400	6 kg	404
GRAH-66	1676 mm	1560	7 kg	444
GRAH-72	1829 mm	1725	8 kg	499
GRAH-84	2134 mm	2050	9 kg	575
GRAH-96	2438 mm	2400	10 kg	654
GRAH-108	2743 mm	2500	10 kg	819
GRAH-120	3048 mm	2800	12 kg	888
GRAH-132	3353 mm	3120	14 kg	959
GRAH-144	3658 mm	3450	15 kg	1031

○ Does not include Remote Control Enclosure (RMB), see page 74.

† Available with CE Mark, add \$10, models GRA(H) -18 through -96 only.

#### All Glo-Ray Aluminum Infrared Models Feature:

**Voltage:** 220 or 240 volt, single phase.

**Toggle Switch (max. 15 Amps) Location:** Chef's left side (unless otherwise specified).

**Leads:** 152 mm leads – server's right.

**Dimensions:** 457-3658 W x 152 D x 64 H mm.

#### OPTIONS AND ACCESSORIES – PAGE 54

#### RECOMMENDED MOUNTING HEIGHTS – PAGE 72



GRAH-48 with optional Sneeze Guards, cord and plug set and T-leg Stands



GRAH-36 with optional Designer Color, infinite switch, cord and plug set and C-leg Stands

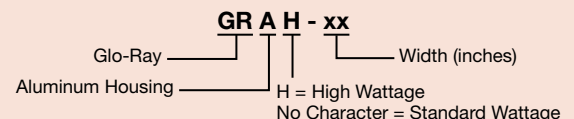



## Glo-Ray® Aluminum Infrared Strip Heaters

continued



**GRAHL-36** with optional Sneeze Guards and adjustable tubular stands

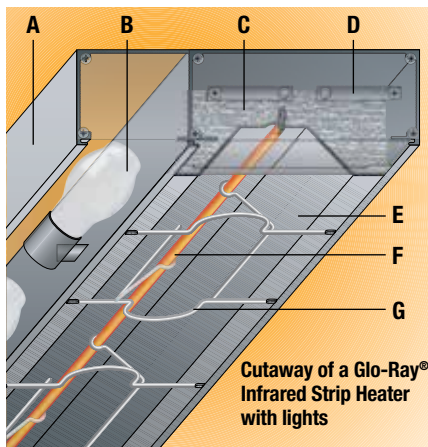

Cutaway of a Glo-Ray® Infrared Strip Heater with lights

- A** Stainless steel or sturdy aluminum housings that do not sag, from 457 up to 3658 mm in 153 mm increments. Stainless steel units available as single units without lights, up to 2438 mm in width
- B** Shatter-resistant incandescent lights (Standard on GRAL/GRAHL)
- C** Heavy-duty insulation minimizes heat loss
- D** Standard hanger tabs are provided
- E** Aluminized reflector retains full heat intensity and directs more heat towards the edges of the holding surface.
- F** Long life metal-sheathed heating element
- G** Protective wire guard supports heating element without affecting heat distribution

### GLO-RAY ALUMINUM INFRARED STRIP HEATERS with LIGHTS

Model	No. of Bulbs	Width	Watts	Ship Weight	List Price <sup>⓪†</sup>
<b>Standard Watt</b>					
GRAL-18	2	457 mm	370	4 kg	\$ 411
GRAL-24	2	610 mm	470	5 kg	427
GRAL-30	2	762 mm	570	5 kg	475
GRAL-36	3	914 mm	755	6 kg	523
GRAL-42	3	1067 mm	855	7 kg	572
GRAL-48	4	1219 mm	1040	8 kg	622
GRAL-54	4	1372 mm	1165	9 kg	678
GRAL-60	5	1524 mm	1350	10 kg	737
GRAL-66	5	1676 mm	1460	10 kg	807
GRAL-72	6	1829 mm	1635	11 kg	899
GRAL-84	7	2134 mm	1920	13 kg	1037
GRAL-96	8	2438 mm	2205	15 kg	1177
GRAL-108	9	2743 mm	2390	16 kg	1416
GRAL-120	10	3048 mm	2700	18 kg	1553
GRAL-132	11	3353 mm	2980	20 kg	1689
GRAL-144	12	3658 mm	3270	22 kg	1829
<b>High Watt</b>					
GRAHL-18	2	457 mm	470	4 kg	\$ 419
GRAHL-24	2	610 mm	620	5 kg	435
GRAHL-30	2	762 mm	780	5 kg	483
GRAHL-36	3	914 mm	980	6 kg	531
GRAHL-42	3	1067 mm	1130	7 kg	580
GRAHL-48	4	1219 mm	1340	8 kg	630
GRAHL-54	4	1372 mm	1490	9 kg	686
GRAHL-60	5	1524 mm	1700	10 kg	745
GRAHL-66	5	1676 mm	1860	10 kg	815
GRAHL-72	6	1829 mm	2085	15 kg	907
GRAHL-84	7	2134 mm	2470	13 kg	1045
GRAHL-96	8	2438 mm	2880	24 kg	1185
GRAHL-108	9	2743 mm	3040	16 kg	1424
GRAHL-120	10	3048 mm	3400	18 kg	1561
GRAHL-132	11	3353 mm	3780	20 kg	1697
GRAHL-144	12	3658 mm	4170	22 kg	1837

⓪ Does not include Remote Control Enclosure (RMB), see page 74.  
 † Available with CE Mark, add \$10, models GRA(H)L -18 through -96 only.

**All Glo-Ray Aluminum Infrared with Lights Models Feature:**  
 Voltage: 220 or 240, single phase.  
 Toggle Switch (max. 15 Amps) Location: Chef's left side – light side (unless otherwise specified).  
 Leads: 152 mm leads – server's right.  
 Dimensions: 457-3658 W x 229 D x 64 H mm

**OPTIONS AND ACCESSORIES – PAGE 54**  
**RECOMMENDED MOUNTING HEIGHTS – PAGE 72**

### GLO-RAY STAINLESS STEEL INFRARED STRIP HEATERS

Model	Width	Watts	Ship Weight	List Price <sup>⓪†</sup>
<b>Standard Watt</b>				
GR-18	457 mm	250	3 kg	\$382
GR-24	610 mm	350	3 kg	402
GR-36	914 mm	575	5 kg	454
GR-48	1219 mm	800	5 kg	494
GR-60	1524 mm	1050	7 kg	558
GR-72	1829 mm	1275	9 kg	663
GR-96	2438 mm	1725	12 kg	802
<b>High Watt</b>				
GRH-18	457 mm	350	4 kg	\$390
GRH-24	610 mm	500	3 kg	410
GRH-36	914 mm	800	5 kg	462
GRH-48	1219 mm	1100	6 kg	502
GRH-60	1524 mm	1400	7 kg	566
GRH-72	1829 mm	1725	9 kg	671
GRH-96	2438 mm	2400	12 kg	810

⓪ Does not include Remote Control Enclosure (RMB), see page 74.  
 † Available with CE Mark, add \$10 (models GR, GRH -18 through -72 only).

**All Glo-Ray Stainless Steel Infrared Models Feature:**  
 Voltage: 220 or 240 volt, single phase.  
 Toggle Switch (max. 15 Amps) Location: Chef's left side.  
 Leads: 152 mm leads – server's right.  
 Dimensions: 610-2438 W x 152 D x 70 H mm.  
**NOTE:** Stainless steel models are not available with lights, Sneeze Guard or as dual or tandem units.  
 Contact factory for stainless marine applications.

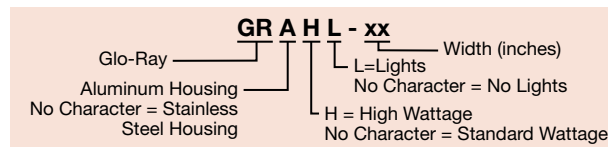

Strip Heaters



**GRAHL-48** with optional Sneeze Guard

Strip Heaters

**OPTIONS** (available at time of purchase only)

**Designer Colors, aluminum models 457-3658 mm – Non-standard colors are non-returnable – Clear Anodized Standard –**

<b>COLOR-6</b>	152 mm Housing for GRA and GRAH models (color selection below)	per 305 mm	\$25
<b>COLOR-9</b>	229 mm Housing for GRAL and GRAHL models (color selection below)	per 305 mm	25
<b>RED</b>	Warm Red	<b>GRAY</b>	Gray Granite
<b>BLACK</b>	Black	<b>WHITE</b>	White Granite
		<b>NAVY</b>	Navy Blue
		<b>GREEN</b>	Hunter Green
		<b>COPPER</b>	Antique Copper

**Gloss Finishes, aluminum models 457-3658 mm – Non-standard colors are non-returnable – Clear Anodized Standard –**

<b>GLOSS-6</b>	152 mm Housing for GRA and GRAH models (Gloss Finish selection below)	per 305 mm	\$34
<b>GLOSS-9</b>	229 mm Housing for GRAL and GRAHL models (Gloss Finish selection below)	per 305 mm	34
<b>RRED</b>	Radiant Red	<b>GGRAY</b>	Glossy Gray
<b>GGOLD</b>	Gleaming Gold	<b>BBLUE</b>	Brilliant Blue
		<b>BBLACK</b>	Bold Black

<b>IND. LGT</b>	Indicator Light (Remote Control only on all Tandem Element units)		15
-----------------	---	--	----

**Power Leads – Extend beyond Standard 152 mm pigtail leads (must specify lead length) –**

<b>LEADS5</b>	305-1525 mm extended Electrical Leads		\$ 20
<b>LEADS10</b>	1829-3048 mm extended Electrical Leads		40
<b>LEADS15</b>	3352-4572 mm extended Electrical Leads		60
<b>LEADS20</b>	4877-6096 mm extended Electrical Leads		80

**Sneeze Guards**

<b>9.375BP1</b>	238 mm Sneeze Guard - one side	per 305 mm	55
<b>9.375BP2</b>	238 mm Sneeze Guard - two sides	per 305 mm	110
<b>14BP1</b>	356 mm Sneeze Guard - one side	per 305 mm	89
<b>14BP2</b>	356 mm Sneeze Guard - two sides	per 305 mm	178
<b>NO BULB</b>	No bulb option (GRAL, GRAHL models only)		No Charge
<b>LIGHTS-ADD'L</b>	Extra Lamps – Installed – max. two per 305 mm less one – one per 305 mm is Standard	each	25
<b>3 ANEAL REFL</b>	Bright Annealed Reflector for lights	per 305 mm	21

**Infinite Control (REMOTE CONTROL ENCLOSURE RECOMMENDED) Consult factory if rating of element exceeds 12.2 Amps –**

<b>BLT INF</b>	Built-in (max. of 12.2 Amps) Remote installation recommended		\$ 37
<b>REM INF</b>	Remote Infinite Switches in lieu of Toggle (max. 12.2 Amps)		37
<b>RMB</b>	Remote Control Enclosure available in Designer Colors and Gloss Finishes – Non-standard colors are non-returnable –		see page 74 for models and prices

**Stands**

<b>ATL</b>	Adjustable Tubular Stands 254-356 mm – not available in Designer Colors – Not available with cord	1 pair	191
<b>NTL-10, -12</b>	Non-Adjustable Tubular Stands specify 254 or 305 mm clearance – Not available in Designer Colors – Not available with cord	1 pair	89
<b>NTL-14, -16</b>	Non-Adjustable Tubular Stands – specify 356 or 406 mm clearance – Not available with cord	1 pair	95
<b>NTL-PAINT</b>	Designer Color or Gloss Finish to match unit color for Non-Adjustable Tubular Stands – Non-standard colors are non-returnable –	1 pair	36
<b>CL-LOW</b>	C-Leg Stand (Standard Watt) – 254 mm clearance – for models up to 1829 mm	1 pair	101
<b>CL-HIGH</b>	C-Leg Stand (High Watt) – 343 mm clearance – for models up to 1829 mm	1 pair	114
<b>TL-10</b>	T-Leg Stand (Standard Watt) 254 mm clearance – for models up to 1829 mm	1 pair	244
<b>TL-13</b>	T-Leg Stand 343 mm clearance – for models up to 1829 mm	1 pair	270
<b>TL-16</b>	T-Leg Stand 406 mm clearance – for models up to 1829 mm	1 pair	288
<b>TL-18</b>	T-Leg Stand 457 mm clearance – for models up to 1829 mm	1 pair	308
<b>CAP-EX</b>	Attached 1829 mm Cord and Plug Set on models up to 2438 mm		29

**ACCESSORIES** (available for purchase at any time)

<b>ADJ ANGLE</b>	Adjustable Angle Brackets (GRA, GRAH models only)	1 pair	\$24
<b>ADJ ANGLE7</b>	178 mm tall Adjustable Angle Bracket	1 pair	27
<b>CHAIN 1</b>	Chain Suspension	per 305 mm	9
<b>GR-ANGLE</b>	Adjustable Angle Brackets (GR and GRH models only)	1 pair	23

**COLORS AND FINISHES – INSIDE BACK COVER**

## Glo-Ray® Aluminum Dual Infrared Strip Heaters

Create a deeper holding area with Glo-Ray Aluminum Dual Infrared Strip Heaters mounted side-by-side, keeping hot food at optimum serving temperatures. The pre-focused heat pattern directs heat from a metal sheathed element across the entire holding surface. The continuous aluminum housing and heavy-duty mountings ensure the durability and quality of Hatco products.

- Ensures maximum flavor, safety and holding time
- Provides even heat distribution – no "cold spots"
- Sturdy extruded aluminum housings that do not sag, from 457 to 3658 mm
- Long life metal sheathed heating elements
- Reflector does not blacken, maintaining a consistent heat pattern

- Reinforced, protective wire guard supports heating element without affecting heat distribution
- 76 or 152 mm spacer available
- Heavy-duty insulation minimizes heat loss
- Additional reflector styles and lower wattage elements available, consult factory for more information

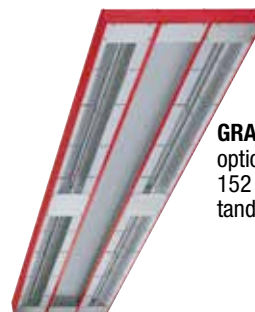

**GRAH-72D** with optional *Designer Color*, 152 mm spacer and tandem elements



**GRAH-36D** with Standard 76 mm spacer

Strip Heaters

### GLO-RAY ALUMINUM DUAL INFRARED STRIP HEATERS

Model	Width	Watts	Ship Weight	List Price <sup>○ ‡</sup>	
				76 mm Spacer	152 mm Spacer
<b>Standard Watt</b>					
GRA-18D	457 mm	500	6 kg	\$ 642	\$ 652
GRA-24D	610 mm	700	7 kg	671	681
GRA-30D	762 mm	900	8 kg	740	755
GRA-36D	914 mm	1150	10 kg	811	826
GRA-42D	1067 mm	1350	10 kg	882	897
GRA-48D	1219 mm	1600	12 kg	952	972
GRA-54D	1372 mm	1850	14 kg	1019	1039
GRA-60D	1524 mm	2100	16 kg	1100	1130
GRA-66D	1676 mm	2320	16 kg	1208	1238
GRA-72D	1829 mm	2550	16 kg	1352	1382
GRA-84D	2134 mm	3000	23 kg	1564	1604
GRA-96D	2438 mm	3450	24 kg	1781	1821
GRA-108D	2743 mm	3700	27 kg	2140	2180
GRA-120D	3048 mm	4200	30 kg	2336	2396
GRA-132D <sup>‡</sup>	3353 mm	4640	34 kg	2535	2595
GRA-144D	3658 mm	5100	37 kg	2737	2797
<b>High Watt</b>					
GRAH-18D	457 mm	700	6 kg	\$ 658	\$ 668
GRAH-24D	610 mm	1000	7 kg	687	697
GRAH-30D	762 mm	1320	8 kg	756	771
GRAH-36D	914 mm	1600	9 kg	827	842
GRAH-42D	1067 mm	1900	11 kg	898	913
GRAH-48D	1219 mm	2200	12 kg	968	988
GRAH-54D	1372 mm	2500	14 kg	1035	1055
GRAH-60D	1524 mm	2800	15 kg	1116	1146
GRAH-66D	1676 mm	3120	17 kg	1224	1254
GRAH-72D <sup>‡</sup>	1829 mm	3450	16 kg	1368	1398
GRAH-84D <sup>‡</sup>	2134 mm	4100	23 kg	1580	1620
GRAH-96D <sup>‡</sup>	2438 mm	4800	24 kg	1797	1837
GRAH-108D	2743 mm	5000	27 kg	2177	2217
GRAH-120D <sup>‡</sup>	3048 mm	5600	30 kg	2375	2435
GRAH-132D	3353 mm	6240	34 kg	2576	2636
GRAH-144D	3658 mm	6900	37 kg	2780	2840

○ Does not include Remote Control Enclosure (RMB), see page 74.  
 ‡ Available with RMB or remote switch only, consult factory for additional charges.  
 † Available with CE Mark, add \$20, (specifics below)  
 GRA(H)-18D through -96D available with CE mark.  
 GRA-96D in 220-230V requires Remote Control Enclosure (RMB)  
 GRAH-72D through-96D in 220-230V and 230-240V require Remote Control Enclosure (RMB), see page 74).

**All Glo-Ray Aluminum Dual Infrared Models Feature:**  
 Voltage: 220 or 240, single phase.  
 Toggle Switch (max. 15 Amps) Location: Chef's left side (unless otherwise specified).  
 Leads: 152 mm leads – server's right.  
 Dimensions: with 76 mm Spacer (Standard): 457-3658 W x 381 D x 64 H mm.  
 with 152 mm Spacer: 457-3658 W x 457 D x 64 H mm.

**OPTIONS AND ACCESSORIES – PAGE 57**  
**RECOMMENDED MOUNTING HEIGHTS – PAGE 72**

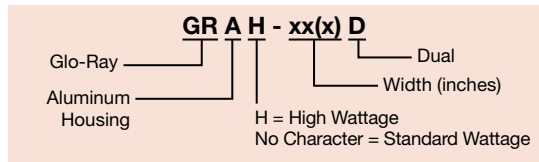

- A Shown with optional shatter-resistant incandescent lights
- B Sturdy extruded aluminum housings that do not sag, from 457 up to 3658 mm
- C Reflector does not blacken, maintaining a consistent heat pattern
- D Standard hanger tab is provided for under shelf or chain installation
- E Heavy-duty insulation minimizes heat loss
- F Long life metal-sheathed heating element
- G Protective wire guard supports heating element without affecting heat distribution

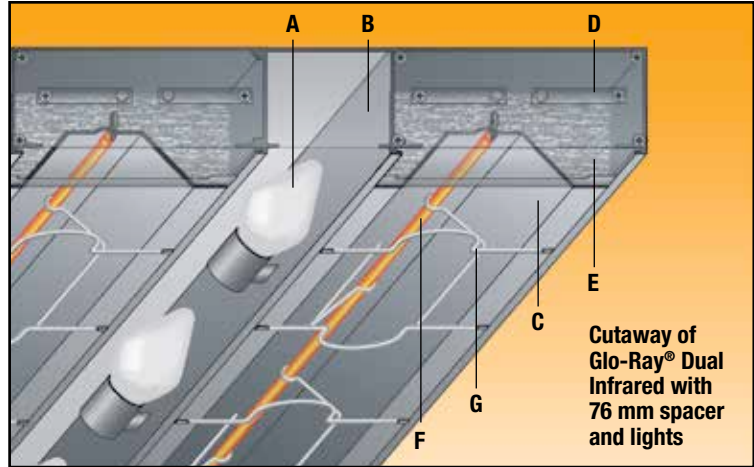

**Toggle Switch:** Max. 15 Amps  
**Infinite Switch:** Max. 12.2 Amps

Strip Heaters

**GLO-RAY ALUMINUM DUAL INFRARED STRIP HEATERS with LIGHTS**

Model	No. of Bulbs	Width	Watts		Ship Weight	List Price <sup>○‡</sup>	
			220V	240V		76 mm Spacer	152 mm Spacer
<b>Standard Watt</b>							
GRAL-18D	2	457 mm	601	620	6 kg	\$ 712	\$ 722
GRAL-24D	2	610 mm	801	820	7 kg	737	747
GRAL-30D	2	762 mm	915	1020	9 kg	822	837
GRAL-36D	3	914 mm	1301	1330	10 kg	908	923
GRAL-42D	3	1067 mm	1501	1530	11 kg	996	1011
GRAL-48D	4	1219 mm	1802	1840	13 kg	1086	1106
GRAL-54D	4	1372 mm	2052	2090	15 kg	1181	1201
GRAL-60D	5	1524 mm	2352	2400	16 kg	1283	1313
GRAL-66D	5	1676 mm	2572	2620	18 kg	1405	1435
GRAL-72D	6	1829 mm	2853	2910	19 kg	1571	1601
GRAL-84D	7	2134 mm	3353	3420	23 kg	1820	1860
GRAL-96D	8	2438 mm	3853	3930	24 kg	2061	2101
GRAL-108D	9	2743 mm	4154	4240	29 kg	2452	2492
GRAL-120D	10	3048 mm	4704	4800	33 kg	2682	2742
GRAL-132D	11	3353 mm	5195	5300	36 kg	2917	2977
GRAL-144D	12	3658 mm	5705	5820	39 kg	3154	3214
<b>High Watt</b>							
GRAHL-18D	2	457 mm	801	820	6 kg	\$ 728	\$ 738
GRAHL-24D	2	610 mm	1101	1120	7 kg	753	763
GRAHL-30D	2	762 mm	1421	1440	9 kg	838	853
GRAHL-36D	3	914 mm	1751	1780	10 kg	924	939
GRAHL-42D	3	1067 mm	2051	2080	11 kg	1012	1027
GRAHL-48D	4	1219 mm	2402	2440	14 kg	1102	1122
GRAHL-54D	4	1372 mm	2702	2740	15 kg	1197	1217
GRAHL-60D	5	1524 mm	3052	3100	17 kg	1299	1329
GRAHL-66D	5	1676 mm	3372	3420	17 kg	1421	1451
GRAHL-72D <sup>‡</sup>	6	1829 mm	3753	3810	19 kg	1587	1617
GRAHL-84D <sup>‡</sup>	7	2134 mm	4453	4520	23 kg	1836	1876
GRAHL-96D <sup>‡</sup>	8	2438 mm	5203	5280	24 kg	2077	2117
GRAHL-108D <sup>‡</sup>	9	2743 mm	5454	5540	29 kg	2386	2426
GRAHL-120D <sup>‡</sup>	10	3048 mm	6104	6200	33 kg	2609	2669
GRAHL-132D <sup>‡</sup>	11	3353 mm	6795	6900	36 kg	2836	2896
GRAHL-144D <sup>‡</sup>	12	3658 mm	7505	7620	39 kg	3065	3125

○ Does not include Remote Control Enclosure (RMB), see page 74.

‡ Available with CE Mark, add \$20 (see specifics below).

GRAL-18D through -96D are available with CE mark.

GRAHL-18D through -96D are available with CE mark (GRAHL-72D, -84D, -96D require Remote Control Enclosure (RMB), see page 74).

‡ Available with RMB or remote switch only, consult factory for additional charges.

**All Glo-Ray Aluminum Dual Infrared with Lights Models Feature:**

Voltage: 220 or 240, single phase.

Toggle Switch (max. 15 Amps) Location: Chef's left side (unless otherwise specified).

Leads: 152 mm leads – server's right.

Dimensions: with 76 mm Spacer (Standard): 381 D x 64 H mm.

with 152 mm Spacer: 457 D x 64 H mm.

**OPTIONS AND ACCESSORIES – PAGE 57**

**RECOMMENDED MOUNTING HEIGHTS – PAGE 72**

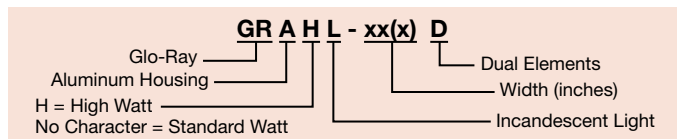





A series of GRAH-60D

**OPTIONS** (available at time of purchase only)**Designer Colors, aluminum models 457-3658 mm – Non-standard colors are non-returnable – Clear Anodized Standard –**

<b>COLOR-15, -18</b>	381 mm and 457 mm housings for GRA, GRAH, GRAL and GRAHL Dual models				<b>per 305 mm</b>	<b>\$36</b>	
<b>RED</b>	Warm Red	<b>GRAY</b>	Gray Granite	<b>NAVY</b>	Navy Blue	<b>COPPER</b>	Antique Copper
<b>BLACK</b>	Black	<b>WHITE</b>	White Granite	<b>GREEN</b>	Hunter Green		

**Gloss Finishes, aluminum models 457-3658 mm – Non-standard colors are non-returnable – Clear Anodized Standard –**

<b>GLOSS-15, -18</b>	381 mm and 457 mm housings for GRA, GRAH, GRAL and GRAHL Dual models				<b>per 305 mm</b>	<b>\$46</b>	
<b>RRED</b>	Radiant Red	<b>GGRAY</b>	Glossy Gray	<b>BBLACK</b>	Bold Black		
<b>GGOLD</b>	Gleaming Gold	<b>BBLUE</b>	Brilliant Blue				

<b>IND. LGT</b>	Indicator Light (remote only)	<b>15</b>
-----------------	-------------------------------	-----------

**Power Leads – Must specify lead length –**

<b>LEADS5</b>	305-1525 mm extended Electrical Leads	<b>\$20</b>
<b>LEADS10</b>	1829-3048 mm extended Electrical Leads	<b>40</b>
<b>LEADS15</b>	3352-4572 mm extended Electrical Leads	<b>60</b>
<b>LEADS20</b>	4877-6096 mm extended Electrical Leads	<b>80</b>

**Sneeze Guards**

<b>9.375BP1</b>	238 mm Sneeze Guard - one side	<b>per 305 mm</b>	<b>\$ 55</b>
<b>9.375BP2</b>	238 mm Sneeze Guard - two sides	<b>per 305 mm</b>	<b>110</b>
<b>14BP1</b>	356 mm Sneeze Guard - one side	<b>per 305 mm</b>	<b>89</b>
<b>14BP2</b>	356 mm Sneeze Guard, - two sides	<b>per 305 mm</b>	<b>178</b>

<b>NO BULB</b>	No bulb option (GRAL-xxD, GRAHL-xxD models only)	<b>No Charge</b>
----------------	--	------------------

<b>LIGHTS-ADD'L</b>	Extra Lamps – Installed (max. two per 305 mm less one) – one per 305 mm is Standard	<b>each</b>	<b>25</b>
---------------------	---	-------------	-----------

<b>3 ANEAL REFL</b>	Bright Annealed Reflector for lights with 76 mm Spacer	<b>per 305 mm</b>	<b>21</b>
---------------------	--	-------------------	-----------

<b>6 ANEAL REFL</b>	Bright Annealed Reflector for lights with 152 mm Spacer	<b>per 305 mm</b>	<b>31</b>
---------------------	---	-------------------	-----------

<b>REM INF</b>	Remote Infinite Control – max. of 12.2 Amps – (CE requires Remote Control Enclosure)		<b>37</b>
----------------	--	--	-----------

<b>RMB</b>	Remote Control Enclosure available in <i>Designer Colors</i> and <i>Gloss Finishes</i> – Non-standard colors are non-returnable –	<b>see page 74 for models and prices</b>
------------	---	--

<b>RMB-ATT</b>	Factory attaches control box to Strip Heater (GRA, GRAH, GRAL and GRAHL Dual models only) – for CE only Must select RMB on page 74 and add cost	<b>35</b>
----------------	--	-----------

**Stands**

<b>ATL-D</b>	Adjustable Tubular Stands 254-356 mm (not available in <i>Designer Colors</i> )	<b>2 pair</b>	<b>382</b>
--------------	---	---------------	------------

<b>NTL-10-D, 12-D</b>	Non-Adjustable Tubular Stands (specify 254 or 305 mm clearance)	<b>2 pair</b>	<b>178</b>
-----------------------	---	---------------	------------

<b>NTL-14-D, 16-D</b>	Non-Adjustable Tubular Stands (specify 356 or 406 mm clearance)	<b>2 pair</b>	<b>190</b>
-----------------------	---	---------------	------------

<b>NTL-PAINT-D</b>	<i>Designer Color</i> or <i>Gloss Finish</i> to match unit color for Non-Adjustable Tubular Stands – Non-standard colors are non-returnable	<b>2 pair</b>	<b>72</b>
--------------------	--	---------------	-----------

**ACCESSORIES** (available for purchase at any time)

<b>ADJ ANGLE-D</b>	Adjustable Angle Brackets for Dual models (see page 73 for illustration)	<b>2 pair</b>	<b>46</b>
--------------------	--	---------------	-----------

<b>ADJ ANGLE7-D</b>	178 mm tall Adjustable Angle Brackets for Dual models (see page 73 for illustration)	<b>2 pair</b>	<b>54</b>
---------------------	--	---------------	-----------

<b>CHAIN 1</b>	Chain Suspension (see page 73 for illustration)	<b>per 305 mm</b>	<b>9</b>
----------------	---	-------------------	----------

**COLORS AND FINISHES – INSIDE BACK COVER**

## Glo-Ray® Narrow Infrared Strip Heaters

Hatco Glo-Ray Narrow Infrared Strip Heaters keep all hot foods at optimum serving temperatures longer, while the slim design fits ideally in buffet areas. Even the most delicate dishes hold that "just-prepared" look. The entire holding surface is heated evenly with no "cold" spots.

- Has a slim design that's only 51 mm in height and 102 mm deep
- Available in widths from 457-1829 mm
- Pre-focused heat pattern maintains serving temperatures longer without continuing to cook the food
- Optional Remote Control Enclosure (RMB) in Designer Colors

GRN-24 in Standard Designer Black with Standard angle brackets



**Toggle Switch:** Max. 15 Amps  
**Infinite Switch:** Max. 12.2 Amps

### GLO-RAY NARROW INFRARED STRIP HEATERS

Model	Width	Watts	Ship Weight	List Price <sup>○*</sup>
<b>Standard Watt</b>				
GRN-18	457 mm	250	2 kg	\$333
GRN-24	610 mm	350	3 kg	352
GRN-30	762 mm	450	4 kg	374
GRN-36	914 mm	575	4 kg	396
GRN-42	1067 mm	675	4 kg	420
GRN-48	1219 mm	800	5 kg	444
GRN-54	1372 mm	925	5 kg	468
GRN-60	1524 mm	1050	6 kg	503
GRN-66	1676 mm	1160	7 kg	549
GRN-72	1829 mm	1275	8 kg	621
<b>High Watt</b>				
GRNH-18	457 mm	350	3 kg	\$341
GRNH-24	610 mm	500	3 kg	360
GRNH-30	762 mm	660	3 kg	382
GRNH-36	914 mm	800	4 kg	404
GRNH-42	1067 mm	950	4 kg	428
GRNH-48	1219 mm	1100	5 kg	452
GRNH-54	1372 mm	1250	5 kg	476
GRNH-60	1524 mm	1400	6 kg	511
GRNH-66	1676 mm	1560	7 kg	557
GRNH-72	1829 mm	1725	8 kg	629

<sup>○</sup> Does not include Remote Control Enclosure (RMB), see page 74.

\* Available with CE Mark, add \$20.

#### All Glo-Ray Narrow Infrared Models Feature:

**Voltage:** 220 or 240, single phase.

**Toggle Switch with Pilot (max. 15 Amps) Location:** Chef's left side (unless otherwise specified).

**Designer Color Angle Brackets:** To match unit color and provide 38 mm clearance between Strip Heater and overshef. Non-standard colors are non-returnable.

**Leads:** 152 mm leads – server's right.

**Dimensions:** 457-1829 W x 102 D x 51 H mm.

#### OPTIONS – PAGE 59

#### RECOMMENDED MOUNTING HEIGHTS – SEE PAGE 72

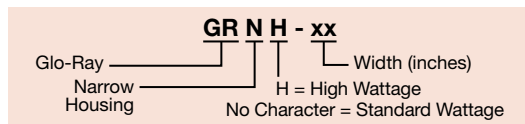

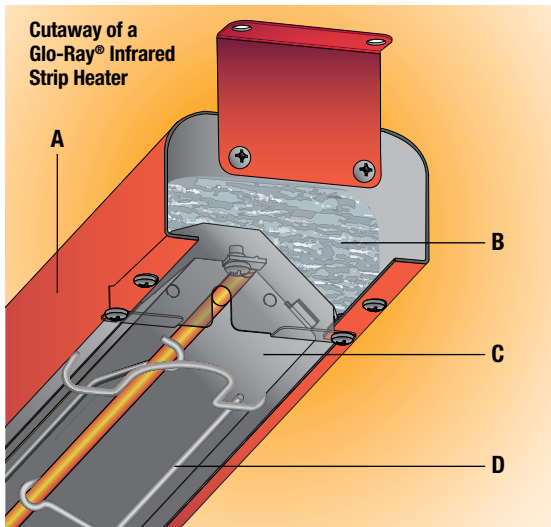

- A** Sturdy housing available in optional stainless steel, or six optional *Designer Colors* (*Designer Black Standard*)
- B** Heavy-duty insulation minimizes heat loss
- C** Aluminized reflector retains full heat intensity and directs more heat towards edges of holding surface
- D** Protective reinforced wire guard supports heating element without affecting heat distribution

Strip Heaters

**OPTIONS** (available at time of purchase only)

<b>Designer Colors – Non-standard colors are non-returnable – Black Standard –</b>				<b>No Charge</b>			
<b>RED</b>	Warm Red	<b>GRAY</b>	Gray Granite	<b>NAVY</b>	Navy Blue	<b>COPPER</b>	Antique Copper
<b>BLACK</b>	Black	<b>WHITE</b>	White Granite	<b>GREEN</b>	Hunter Green		
<b>Stainless Steel – Additional Charge – Non-standard colors are non-returnable –</b>				<b>per 305 mm \$24</b>			
	<b>SS</b>	Stainless Steel					
<b>Power Leads – Must specify lead length –</b>							
<b>LEADS5</b>	305-1525 mm extended Electrical Leads						<b>\$20</b>
<b>LEADS10</b>	1829-3048 mm extended Electrical Leads						<b>40</b>
<b>LEADS15</b>	3352-4572 mm extended Electrical Leads						<b>60</b>
<b>LEADS20</b>	4877-6096 mm extended Electrical Leads						<b>80</b>
<b>RMB</b>	Remote Control Enclosure available in <i>Designer Colors</i> or <i>Gloss Finishes</i> – Non-standard colors are non-returnable –						<b>see page 74</b>
<b>TABS</b>	Stainless steel Hanger tabs in lieu of Angle Brackets						<b>No Charge</b>
<b>CHAIN-HOOK</b>	Two S Hooks with two 153 mm lengths of chain						<b>each 9</b>
<b>Stands</b>							
<b>NTL-10, -12</b>	Non-Adjustable Tubular Stands – specify 254 or 305 mm clearance and power location						<b>1 pair 89</b>
<b>NTL-14, -16</b>	Non-Adjustable Tubular Stands – specify 356 or 406 mm clearance and power location						<b>1 pair 95</b>
<b>NTL-PAINT</b>	<i>Designer Color</i> to match unit color for Non-Adjustable Tubular Stands – Non-standard colors are non-returnable –						<b>1 pair 36</b>

**COLORS AND FINISHES – INSIDE BACK COVER**

## Glo-Ray® Aluminum Infra-Black® High Watt Strip Heaters

For foodwarming at a close range to food product, the Glo-Ray Aluminum Infra-Black High Watt heat technology is ideal, emitting a solid panel of uniform heat. Sturdy continuous single or dual extruded aluminum housings assure quality, durability and a variety of widths, depths, mounting arrangements and colors, will fit your operation.

- Provides ideal amount of heat for limited space operations, mounted 102 to 254 mm above target surface for singles and 203 to 356 mm for duals
- Infra-Black emitter provides even heat distribution – eliminating hot spots
- Sturdy aluminum housings that do not sag, from 457 to 1829 mm in 152 mm increments

- Heavy-duty insulation keeps the exterior housing cool
- Protective wire guard supports heating element without affecting heat distribution
- Standard 76 mm spacer or optional 152 mm spacer available on dual models with or without lights (see next page)



**GRAIH-36** with optional wire guard (requires TCBI or Remote Control Enclosure - RMB)

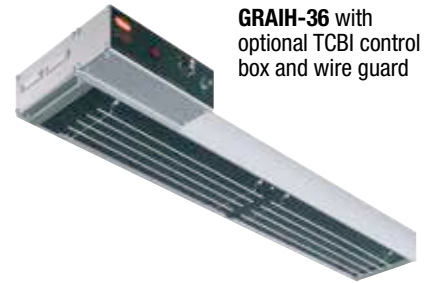

**GRAIH-36** with optional TCBI control box and wire guard

**Toggle Switch:** Max. 15 Amps  
**Infinite Switch:** Max. 12.2 Amps

### GLO-RAY ALUMINUM INFRA-BLACK HIGH WATT STRIP HEATERS (must specify and add price of RMB or TCBI)

Model #	Width	Watts	Ship Weight $\diamond$	List Price $\circ$
GRAIH-18	457 mm	350	5 kg	<b>\$433</b>
GRAIH-24	610 mm	500	5 kg	<b>459</b>
GRAIH-30	762 mm	660	5 kg	<b>487</b>
GRAIH-36	914 mm	800	6 kg	<b>516</b>
GRAIH-42	1067 mm	950	7 kg	<b>548</b>
GRAIH-48	1219 mm	1100	7 kg	<b>576</b>
GRAIH-54	1372 mm	1250	8 kg	<b>603</b>
GRAIH-60	1524 mm	1400	9 kg	<b>646</b>
GRAIH-66	1676 mm	1560	10 kg	<b>696</b>
GRAIH-72	1829 mm	1725	11 kg	<b>790</b>

### GLO-RAY ALUMINUM INFRA-BLACK HIGH WATT STRIP HEATERS with LIGHTS (must specify and add price of RMB or TCBI)

Model #	No. of Bulbs	Width	Watts		Ship Weight $\diamond$	List Price $\circ$
			220V	240V		
GRAIHL-18	2	457 mm	450	470	5 kg	<b>\$ 578</b>
GRAIHL-24	2	610 mm	600	620	6 kg	<b>608</b>
GRAIHL-30	2	762 mm	760	780	7 kg	<b>666</b>
GRAIHL-36	3	914 mm	950	980	8 kg	<b>729</b>
GRAIHL-42	3	1067 mm	1100	1130	9 kg	<b>795</b>
GRAIHL-48	4	1219 mm	1300	1340	10 kg	<b>857</b>
GRAIHL-54	4	1372 mm	1450	1490	11 kg	<b>919</b>
GRAIHL-60	5	1524 mm	1650	1700	12 kg	<b>1006</b>
GRAIHL-66	5	1676 mm	1810	1860	13 kg	<b>1100</b>
GRAIHL-72	6	1829 mm	2025	2085	14 kg	<b>1222</b>

$\diamond$  Does not include Remote Control Enclosure (RMB).

$\circ$  Does not include Remote Control Enclosure (RMB) or Thermostatic Control Box (TCBI). Must choose either RMB (see page 74) or TCBI (see OPTIONS on page 62).

\* Available with CE Mark at no added charge, GRAIH(L)-18 through -66 only.

#### All Glo-Ray Aluminum Infra-Black High Watt Models Feature:

**Voltage:** 220 or 240, single phase.

**Leads:** 152 mm leads – server's right.

**Dimensions:** GRAIH: 457-1829 W x 152 D x 64 H mm.

GRAIHL: 457-1829 W x 229 D x 64 H mm.

**TCBI Control Enclosure Dimensions (not including switches):** 203 W x 76 D x 64 H mm.

**Control Enclosure Location:** Chef's left side (unless otherwise specified).

#### OPTIONS AND ACCESSORIES – PAGE 62

#### RECOMMENDED MOUNTING HEIGHTS – PAGE 72

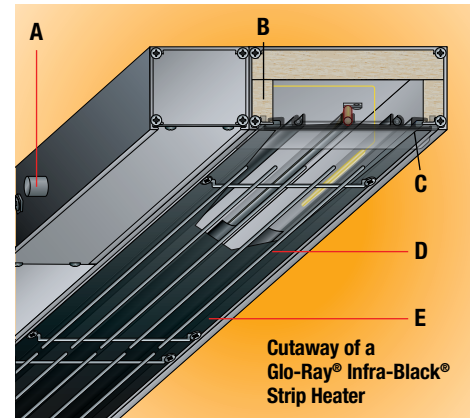

**Cutaway of a Glo-Ray® Infra-Black® Strip Heater**

**A** Thermostatically controlled to regulate heat and provide consistent temperature – optional Remote Control Enclosure (RMB) available

**B** Heavy-duty insulation minimizes heat loss

**C** Provides ideal amount of heat for limited space operations, effectively holding product

**D** Protective wire guard supports heating element without affecting heat distribution

**E** Infra-Black emitter provides even heat distribution, eliminating hot spots for close applications

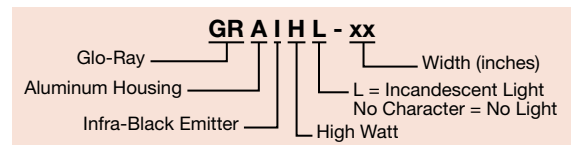





## Glo-Ray® Aluminum Infra-Black® High Watt Dual Strip Heaters

continued



GRAIHL-24D in optional Radiant Red Gloss Finish



GRAIH-60D

Toggle Switch: Max. 15 Amps  
Infinite Switch: Max. 12.2 Amps

### GLO-RAY ALUMINIUM INFRA-BLACK HIGH WATT DUAL STRIP HEATERS (must specify and add price of RMB or TCBI)

Model#	Width	Watts	Ship Weight <sup>◇</sup>	List Price <sup>○</sup>	
				76 mm Spacer	152 mm Spacer
GRAIH-18D	457 mm	700	6 kg	\$ 995	\$ 1005
GRAIH-24D	610 mm	1000	10 kg	1051	1061
GRAIH-30D	762 mm	1320	10 kg	1136	1151
GRAIH-36D	914 mm	1600	12 kg	1224	1239
GRAIH-42D	1067 mm	1900	16 kg	1313	1328
GRAIH-48D	1219 mm	2200	15 kg	1405	1425
GRAIH-54D	1372 mm	2500	19 kg	1496	1516
GRAIH-60D	1524 mm	2800	21 kg	1619	1649
GRAIH-66D	1676 mm	3120	20 kg	1757	1787
GRAIH-72D	1829 mm	3450	22 kg	1964	1994

### GLO-RAY ALUMINIUM INFRA-BLACK HIGH WATT DUAL STRIP HEATERS with LIGHTS (must specify and add price of RMB or TCBI)

Model#	No. of Bulbs	Width	Watts		Ship Weight <sup>◇</sup>	List Price <sup>○</sup>	
			220V	240V		76 mm Spacer	152 mm Spacer
GRAIHL-18D	2	457 mm	800	820	7 kg	\$ 1062	\$1072
GRAIHL-24D	2	610 mm	1100	1120	5 kg	1120	1130
GRAIHL-30D	2	762 mm	1420	1440	11 kg	1226	1241
GRAIHL-36D	3	914 mm	1750	1780	13 kg	1333	1348
GRAIHL-42D	3	1067 mm	2050	2080	15 kg	1435	1450
GRAIHL-48D	4	1219 mm	2400	2440	16 kg	1538	1558
GRAIHL-54D	4	1372 mm	2700	2740	18 kg	1641	1661
GRAIHL-60D	5	1524 mm	3050	3100	21 kg	1792	1822
GRAIHL-66D	5	1676 mm	3370	3420	20 kg	1955	1985

◇ Does not include Remote Control Enclosure (RMB).

○ Does not include Remote Control Enclosure (RMB) or Thermostatic Control Box (TCBI). Must choose either RMB (see page 74) or TCBI (see OPTIONS on page 62).

\* Available with CE Mark at no added charge, GRAIH(L)-18D through -66 only.

#### All Glo-Ray Aluminum Infra-Black High Watt Dual Feature:

Voltage: 220 or 240, single phase.

Leads: 152 mm leads – server's right.

Dimensions: GRAIH-xxD with Standard 76 mm Spacer: 457-1829 W x 381 D x 64 H mm.

GRAIHL-xxD with Standard 76 mm Spacer: 457-1676 W x 381 D x 64 H mm.

GRAIH-xxD with 152 mm Spacer: 457-1829 W x 457 D x 64 H mm.

GRAIHL-xxD with 152 mm Spacer: 457-1676 W x 457 D x 64 H mm.

TCBI Control Enclosure Dimensions (not including switches): 203 W x 76 D x 64 H mm.

Control Enclosure Location: Chef's left side (Unless otherwise specified).

#### OPTIONS AND ACCESSORIES – PAGE 62

#### RECOMMENDED MOUNTING HEIGHTS – PAGE 72

Strip Heaters

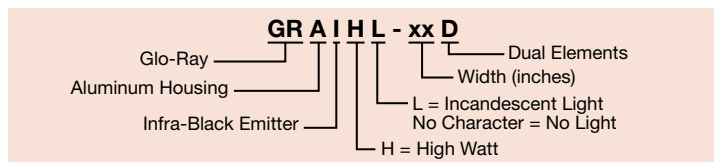



GRAIH-72 with optional wire guard

**OPTIONS** (available at time of purchase only)

**Designer Colors – Non-standard colors are non-returnable – Clear Anodized Standard –**

<b>COLOR-6</b>	152 mm Housing for GRAIH models ( <i>Designer Color</i> selections below)	per 305 mm	\$25
<b>COLOR-9</b>	229 mm Housing for GRAIHL models ( <i>Designer Color</i> selections below)	per 305 mm	25
<b>COLOR-15, -18</b>	381 mm and 457 mm Housings for GRAIH and GRAIHL Dual models ( <i>Designer Color</i> selections below)	per 305 mm	36
	<b>RED</b> Warm Red <b>GRAY</b> Gray Granite <b>NAVY</b> Navy Blue <b>COPPER</b> Antique Copper		
	<b>BLACK</b> Black <b>WHITE</b> White Granite <b>GREEN</b> Hunter Green		

**Gloss Finishes – Non-standard colors are non-returnable – Clear Anodized Standard –**

<b>GLOSS-6</b>	152 mm Housing for GRAIH models ( <i>Gloss Finish</i> selections below)	per 305 mm	No Charge
<b>GLOSS-9</b>	229 mm Housing for GRAIHL models ( <i>Gloss Finish</i> selections below)	per 305 mm	34
<b>GLOSS-15, -18</b>	381 mm and 457 mm Housings for GRAIH and GRAIHL Dual models ( <i>Gloss Finish</i> selections below)	per 305 mm	46
	<b>RRED</b> Radiant Red <b>GGRAY</b> Glossy Gray		
	<b>GGOLD</b> Gleaming Gold <b>BBLUE</b> Brilliant Blue <b>BBLACK</b> Bold Black		

<b>AIH18WG -AIH72WG</b>	Element Wire Guard (Dual models require two sets)	per 305 mm (per side)	\$26
<b>RMB</b>	Remote Control Enclosure available in <i>Designer Colors</i> and <i>Gloss Finishes</i> – Non-standard colors are non-returnable –	<b>See page 74 for models and prices</b>	
<b>TCBI</b>	Thermostatic Control Box with Indicator Lights		\$172

**Stands**

<b>AIH4NTL</b>	102 mm Non-Adjustable Tubular Stands	1 pair	89
<b>AIH6NTL</b>	152 mm Non-Adjustable Tubular Stands	1 pair	89
<b>AIH7.5NTL-D</b>	191 mm Non-Adjustable Tubular Stands	2 pair	178
<b>AIH8NTL</b>	203 mm Non-Adjustable Tubular Stands (Dual models require two pair)	1 pair	89
<b>AIH10NTL</b>	254 mm Non-Adjustable Tubular Stands (Dual models require two pair)	1 pair	89
<b>AIH12NTL-D</b>	305 mm Non-Adjustable Tubular Stands	2 pair	178
<b>AIH14NTL-D</b>	356 mm Non-Adjustable Tubular Stands	2 pair	190
<b>NTL-PAINT</b>	<i>Designer Color</i> or <i>Gloss Finish</i> to match unit color for Non-Adjustable Tubular Stands Non-standard colors are non-returnable –	1 pair	36
<b>NTL-PAINT-D</b>	<i>Designer Color</i> or <i>Gloss Finish</i> to match unit color for Dual Non-Adjustable Tubular Stands Non-standard colors are non-returnable –	2 pair	72

**Power Leads – Extend beyond Standard 914 mm – Units come with 152 mm pigtail leads (must specify lead length) –**

<b>HTLEADS5</b>	305-1525 mm extended Electrical Leads		\$ 30
<b>HTLEADS10</b>	1829-3048 mm extended Electrical Leads		60
<b>HTLEADS15</b>	3352-4572 mm extended Electrical Leads		90
<b>HTLEADS20</b>	4877-6096 mm extended Electrical Leads		120

**ACCESSORIES** (available for purchase at any time)

<b>ADJ ANGLE</b>	Adjustable Angle Brackets (see page 73 for illustration)	1 pair	\$24
<b>ADJ ANGLE7</b>	178 mm tall Adjustable Angle Brackets (see page 73 for illustration)	1 pair	27
<b>ADJ ANGLE-D</b>	Adjustable Angle Brackets for Dual models (see page 73 for illustration)	2 pair	46
<b>ADJ ANGLE7-D</b>	178 mm tall Adjustable Angle Brackets for Dual models (see page 73 for illustration)	2 pair	54
<b>CHAIN 1</b>	Chain Suspension (see page 73 for illustration)	per 305 mm	9

**COLORS AND FINISHES – INSIDE BACK COVER**

## Glo-Ray® Designer Aluminum Infrared Strip Heaters

Hatco Glo-Ray Designer Aluminum Infrared Strip Heaters safely keep all hot foods at optimum serving temperatures longer. This modern design is ideal for front-of-the-house use. Units are offered in continuous housings up to 2223 mm, are available in Designer Colors to match most décors and include 356 mm Designer non-adjustable stands.

**Toggle Switch:** Max. 15 Amps  
**Infinite Switch:** Max. 12.2 Amps

- Pre-focused heat maintains safe serving temperatures longer without continuing to cook the food
- Available in widths from 546 to 2223 mm
- Available in a variety of models, configurations, colors and accessories to provide unlimited flexibility – Non-standard colors are non-returnable
- Optional coated, shatter-resistant incandescent lights enhance product displays while safeguarding food from bulb breakage
- Optional Sneeze Guards

- Black corner caps and inset panels Standard
  - Additional reflector styles and lower wattage elements available, consult factory for more information
- continued on next page...*



**GR2AH-36** with Designer non-adjustable stands and optional Designer Color inset panels

Strip Heaters

### GLO-RAY DESIGNER ALUMINUM INFRARED STRIP HEATERS (must specify and add price of RMB)

Model*	Width	Watts	Ship Weight	List Price
<b>Standard Watt</b>				
GR2A-18	546 mm	250	9 kg	\$ 1030
GR2A-24	699 mm	350	9 kg	1070
GR2A-30	851 mm	450	12 kg	1114
GR2A-36	1003 mm	575	17 kg	1157
GR2A-42	1156 mm	675	17 kg	1198
GR2A-48	1308 mm	800	20 kg	1242
GR2A-54	1460 mm	925	20 kg	1290
GR2A-60	1613 mm	1050	18 kg	1349
GR2A-66	1765 mm	1160	18 kg	1409
GR2A-72	1918 mm	1275	19 kg	1495
GR2A-84	2223 mm	1500	54 kg	1596

<b>High Watt</b>				
GR2AH-18	546 mm	350	12 kg	\$ 1038
GR2AH-24	699 mm	500	9 kg	1078
GR2AH-30	851 mm	660	12 kg	1122
GR2AH-36	1003 mm	800	12 kg	1165
GR2AH-42	1156 mm	950	15 kg	1206
GR2AH-48	1308 mm	1100	12 kg	1250
GR2AH-54	1460 mm	1250	20 kg	1298
GR2AH-60	1613 mm	1400	18 kg	1357
GR2AH-66	1765 mm	1560	18 kg	1417
GR2AH-72	1918 mm	1725	19 kg	1503
GR2AH-84	2223 mm	2050	21 kg	1604

- When no color is specified, color inset panels and corner caps will be black. Non-standard colors are non-returnable.
- ◇ Does not include Remote Control Enclosure (RMB).
- Does not include Remote Control Enclosure (RMB). Must choose RMB (see page 74).
- ‡ Available with CE Mark, add \$10.

**All Glo-Ray Designer Aluminum Infrared Models Feature:**

**Voltage:** 220 or 240, single phase.  
**Switch Location:** Remote only (see page 74).  
**Leads:** 1524 mm leads through ½" conduit in leg cavity.  
**Dimensions without Stands:** 546-2223 W x 305 D x 89 H mm.

**OPTIONS AND ACCESSORIES – PAGE 65**  
**RECOMMENDED MOUNTING HEIGHTS – PAGE 72**

### Cutaway of a Designer Glo-Ray® Infrared Strip Heater

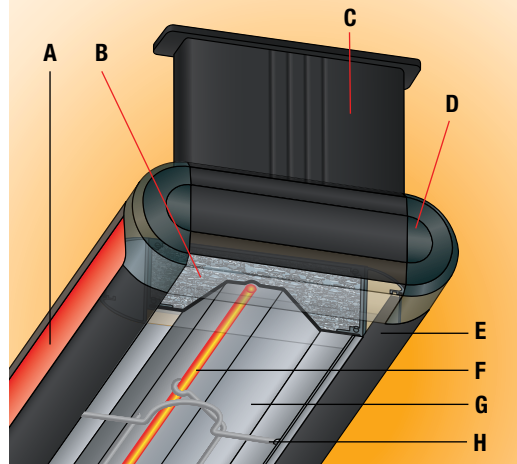

- A** Choice of seven Designer Color inset panels and attractive styling for front-of-the-house applications
- B** Heavy-duty insulation minimizes heat loss
- C** Non-adjustable stand conceals the power wiring, available for counter or overhead mounting
- D** Accent color corners available in Dark Gray or Black (Standard)
- E** Sturdy aluminum extrusion construction; available in clear anodized aluminum finish (Standard) or one of seven Designer Colors for housings (shown in optional Designer Black)
- F** Long life metal-sheathed heating element
- G** Aluminized reflectors won't discolor, so heat can be reflected and directed to the food product being held
- H** Protective wire guard supports heating element without affecting heat distribution

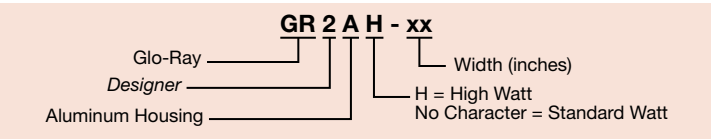

## Glo-Ray® Designer Aluminum Infrared Strip Heaters

continued



**GR2AHL-24** with Designer non-adjustable stands and optional Sneeze Guards and Designer Color inset panels

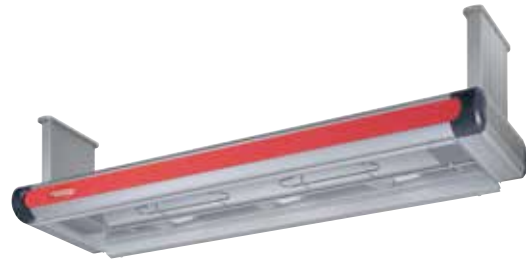

**GR2AHL-36** with optional overhead mounts and Designer Color inset panels

Strip Heaters

### GLO-RAY DESIGNER ALUMINUM INFRARED STRIP HEATERS with LIGHTS (must specify and add price of RMB)

Model*	No. of Bulbs	Width	Watts	Ship Weight◇	List Price○‡
<b>Standard Watt</b>					
GR2AL-18	2	546 mm	370	15 kg	\$1172
GR2AL-24	2	699 mm	470	11 kg	1219
GR2AL-30	2	851 mm	570	13 kg	1289
GR2AL-36	3	1003 mm	755	15 kg	1366
GR2AL-42	3	1156 mm	855	16 kg	1446
GR2AL-48	4	1308 mm	1040	16 kg	1526
GR2AL-54	4	1460 mm	1165	22 kg	1610
GR2AL-60	5	1613 mm	1350	24 kg	1697
GR2AL-66	5	1765 mm	1460	26 kg	1791
GR2AL-72	6	1918 mm	1635	26 kg	1911
GR2AL-84	7	2223 mm	1920	28 kg	2066
<b>High Watt</b>					
GR2AHL-18	2	546 mm	470	12 kg	\$1180
GR2AHL-24	2	699 mm	620	11 kg	1227
GR2AHL-30	2	851 mm	780	13 kg	1297
GR2AHL-36	3	1003 mm	980	15 kg	1374
GR2AHL-42	3	1156 mm	1130	16 kg	1454
GR2AHL-48	4	1308 mm	1340	22 kg	1534
GR2AHL-54	4	1460 mm	1490	22 kg	1618
GR2AHL-60	5	1613 mm	1700	25 kg	1705
GR2AHL-66	5	1765 mm	1860	26 kg	1799
GR2AHL-72	6	1918 mm	2085	26 kg	1919
GR2AHL-84	7	2223 mm	2470	28 kg	2074

\* When no color is specified, color inset panels and corner caps will be black. Non-standard colors are non-returnable.

◇ Does not include Remote Control Enclosure (RMB).

○ Does not include Remote Control Enclosure (RMB). Must choose RMB (see page 74).

‡ Available with CE Mark, add \$10.

#### All Glo-Ray Designer Aluminum Infrared Models with Lights Feature:

Voltage: 220 or 240, single phase.

Switch Location: Remote only (see page 74).

Leads: 1524 mm leads through ½" conduit in leg cavity.

Dimensions without Stands: 546-2223 W x 305 D x 89 H mm.

### OPTIONS AND ACCESSORIES – PAGE 65 RECOMMENDED MOUNTING HEIGHTS – PAGE 72







**GR2AHL-84** with Standard Designer non-adjustable stands and optional Designer Color, inset panels and Sneeze Guards

Strip Heaters

**OPTIONS** (available at time of purchase only)

**Designer Colors for aluminum models 546-2223 mm – includes stands –**

**Non-standard colors are non-returnable – Clear Anodized Standard –**

<b>COLOR-6</b>	229 mm Housing for GR2A and GR2AH models (Designer Color selection below)						<b>per 305 mm</b>	<b>\$25</b>
<b>COLOR-9</b>	305 mm Housing for GR2AL and GR2AHL models (Designer Color selection below)						<b>per 305 mm</b>	<b>25</b>

<b>RED</b>	Warm Red	<b>GRAY</b>	Gray Granite	<b>NAVY</b>	Navy Blue	<b>COPPER</b>	Antique Copper
<b>BLACK</b>	Black	<b>WHITE</b>	White Granite	<b>GREEN</b>	Hunter Green		

**Designer Inset Panel Colors – Non-standard colors are non-returnable – Black Standard –**

**No Charge**

<b>RED</b>	Warm Red	<b>WHITE</b>	White Granite	<b>GREEN</b>	Hunter Green
<b>GRAY</b>	Gray Granite	<b>NAVY</b>	Navy Blue	<b>COPPER</b>	Antique Copper

**Designer Corner Caps – Non-standard colors are non-returnable – Black Standard –**

**No Charge**

**DKGRAY** Dark Gray Corner Caps

**RMB** Remote Control Enclosure (required)

**see page 74 for models and prices**

**NO CONTROL** No control included (GR2A, GR2AL, models only) –

Requires selection of RMB2-xx control (see page 74)

**No Charge**

**Designer Remote Control Enclosures – Non-standard colors are non-returnable – Clear Anodized Standard –**

<b>RMB-COLOR</b>	Remote Control Enclosure Housing in Designer Color						<b>\$ 36</b>
<b>RED</b>	Warm Red	<b>GRAY</b>	Gray Granite	<b>NAVY</b>	Navy Blue	<b>COPPER</b>	Antique Copper
<b>BLACK</b>	Black	<b>WHITE</b>	White Granite	<b>GREEN</b>	Hunter Green		

**Sneeze Guards**

<b>7.5BP1</b>	191 mm Sneeze Guard - one side	<b>per 305 mm</b>	<b>\$ 55</b>
<b>7.5BP2</b>	191 mm Sneeze Guard - two sides	<b>per 305 mm</b>	<b>110</b>
<b>14BP1</b>	356 mm Sneeze Guard - one side	<b>per 305 mm</b>	<b>89</b>
<b>14BP2</b>	356 mm Sneeze Guard - two sides	<b>per 305 mm</b>	<b>178</b>

**NTH2-10, -12, -16** Designer Color Non-Adjustable Stands to match unit color: 254, 305 or 406 mm in lieu of Standard 356 mm Stands –

**No Charge**

Non-standard colors are non-returnable –

**NTH2-4** 102 mm Designer Color Overhead Mounts to match unit color in lieu of 356 mm Standard Legs –

**No Charge**

Non-standard colors are non-returnable –

**NO BULB** No bulb option (GR2AL, GR2AHL models only)

**No Charge**

**LIGHTS-ADD'L** Extra Lamps – installed (max. two per 305 mm less one) – one per 305 mm is Standard

**each 25**

**Power Leads – Extended beyond Standard 1524 mm conduit (must specify lead length) –**

<b>LEADS5</b>	305-1525 mm extended Electrical Leads	<b>\$20</b>
<b>LEADS10</b>	1829-3048 mm extended Electrical Leads	<b>40</b>
<b>LEADS15</b>	3352-4572 mm extended Electrical Leads	<b>60</b>
<b>LEADS20</b>	4877-6096 mm extended Electrical Leads	<b>80</b>

**COLORS AND FINISHES – INSIDE BACK COVER**

## Glo-Ray® Designer Aluminum Dual Infrared Strip Heaters

Glo-Ray Designer Aluminum Dual Infrared Strip Heaters allow side-by-side mounting of two warmers to provide a deeper holding area, keeping hot food at optimum serving temperatures. These modern front-of-the-house warmers have 76 mm spacers Standard with optional 152 mm spacers. Units are available in optional Designer Colors to match most décors.

- Sturdy continuous aluminum housings eliminate sagging
- Pre-focused heat pattern directs heat from a tubular element to bathe the entire holding surface, holding food safely
- Available in widths from 546 to 2223 mm
- Variety of models, configurations, colors and accessories provide unlimited flexibility – Non-standard colors are non-returnable
- Optional Sneeze Guards, that meet food safety standards, can be ordered for display areas and buffet lines
- Optional shatter-resistant incandescent lights available
- Black corner caps and inset panels Standard
- Additional reflector styles and lower wattage elements available, consult factory for more information



GR2AH-24D with Standard Designer non-adjustable stands, optional Sneeze Guards and Designer Color inset panels

**Toggle Switch:** Max. 15 Amps  
**Infinite Switch:** Max. 12.2 Amps

### GLO-RAY DESIGNER ALUMINUM DUAL INFRARED STRIP HEATERS (must specify and add price of RMB)

Model*	Width	Watts	Ship Weight <sup>◇</sup>	List Price <sup>○‡</sup>	
				76 mm Spacer	152 mm Spacer
<b>Standard Watt</b>					
GR2A-18D	546 mm	500	13 kg	\$1493	\$1503
GR2A-24D	699 mm	700	14 kg	1551	1561
GR2A-30D	851 mm	900	17 kg	1641	1656
GR2A-36D	1003 mm	1150	17 kg	1732	1747
GR2A-42D	1156 mm	1350	19 kg	1824	1839
GR2A-48D	1308 mm	1600	20 kg	1916	1936
GR2A-54D	1460 mm	1850	24 kg	2008	2028
GR2A-60D	1613 mm	2100	27 kg	2128	2158
GR2A-66D	1765 mm	2320	70 kg	2248	2278
GR2A-72D	1918 mm	2550	29 kg	2427	2457
GR2A-84D	2223 mm	3000	38 kg	2639	2679
<b>High Watt</b>					
GR2AH-18D	546 mm	700	20 kg	\$1509	\$1519
GR2AH-24D	699 mm	1000	13 kg	1567	1577
GR2AH-30D	851 mm	1320	17 kg	1657	1672
GR2AH-36D	1003 mm	1600	17 kg	1748	1763
GR2AH-42D	1156 mm	1900	22 kg	1840	1855
GR2AH-48D	1308 mm	2200	25 kg	1932	1952
GR2AH-54D	1460 mm	2500	27 kg	2024	2044
GR2AH-60D	1613 mm	2800	25 kg	2144	2174
GR2AH-66D	1765 mm	3120	29 kg	2264	2294
GR2AH-72D	1918 mm	3450	28 kg	2443	2473
GR2AH-84D	2223 mm	4100	48 kg	2655	2695

- When no color is specified, color inset panels and corner caps will be black – Non-standard colors are non-returnable.
- ◇ Does not include Remote Control Enclosure (RMB).
- Does not include Remote Control Enclosure (RMB). Must choose RMB (see page 74).
- ‡ Available with CE Mark, add \$20 (see specifics below).  
 GR2A-18D through -84D available with CE mark.  
 GR2AH-18D through -84D available with CE mark. (GR2AH-72D, -84D require Remote Control Enclosure (RMB), see page 74).

**All Glo-Ray Designer Aluminium Dual Infrared Models Feature:**

**Voltage:** 220 or 240, single phase.  
**Switch Location:** Remote only (see page 74).  
**Leads:** 1524 mm leads through ½" conduit in leg cavity.  
**Dimensions:** with 76 mm Spacer (Standard): 546-2223 W x 457 D x 89 H mm.  
 with 152 mm Spacer: 546-2223 W x 533 D x 89 H mm.

**OPTIONS AND ACCESSORIES – PAGE 68**  
**RECOMMENDED MOUNTING HEIGHTS – PAGE 72**

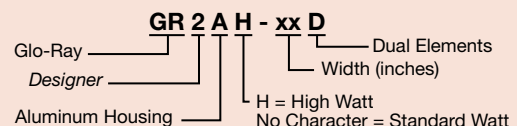



# Glo-Ray® Designer Aluminum Dual Infrared Strip Heaters

continued

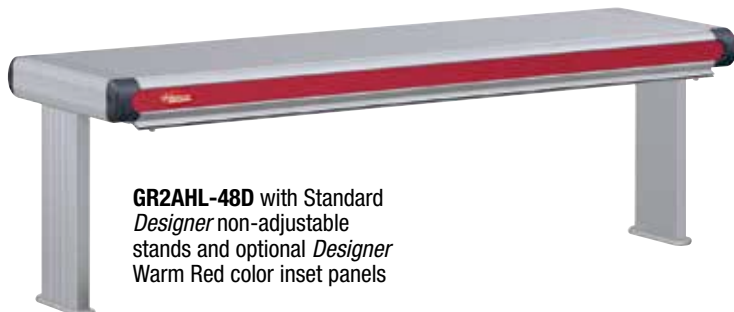

**GR2AHL-48D** with Standard Designer non-adjustable stands and optional Designer Warm Red color inset panels

**Toggle Switch:** Max. 15 Amps  
**Infinite Switch:** Max. 12.2 Amps

**GLO-RAY DESIGNER ALUMINUM DUAL INFRARED STRIP HEATERS with LIGHTS (must specify and add price of RMB)**

Strip Heaters

Model*	No. of Bulbs	Width	Watts	Ship Weight <sup>◇</sup>	List Price <sup>○ ‡</sup>	
					76 mm Spacer	152 mm Spacer
<b>Standard Watt</b>						
GR2AL-18D	2	546 mm	620	20 kg	\$1563	\$1573
GR2AL-24D	2	699 mm	820	15 kg	1621	1631
GR2AL-30D	2	851 mm	1020	24 kg	1727	1742
GR2AL-36D	3	1003 mm	1330	18 kg	1836	1851
GR2AL-42D	3	1156 mm	1530	21 kg	1944	1959
GR2AL-48D	4	1308 mm	1840	21 kg	2053	2073
GR2AL-54D	4	1460 mm	2090	23 kg	2164	2184
GR2AL-60D	5	1613 mm	2400	25 kg	2307	2337
GR2AL-66D	5	1765 mm	2620	30 kg	2453	2483
GR2AL-72D	6	1918 mm	2910	34 kg	2651	2681
GR2AL-84D	7	2223 mm	3420	37 kg	2914	2954
<b>High Watt</b>						
GR2AHL-18D	2	546 mm	820	20 kg	\$1579	\$1589
GR2AHL-24D	2	699 mm	1120	15 kg	1637	1647
GR2AHL-30D	2	851 mm	1440	16 kg	1743	1758
GR2AHL-36D	3	1003 mm	1780	18 kg	1852	1867
GR2AHL-42D	3	1156 mm	2080	21 kg	1960	1975
GR2AHL-48D	4	1308 mm	2440	21 kg	2069	2089
GR2AHL-54D	4	1460 mm	2740	23 kg	2180	2200
GR2AHL-60D	5	1613 mm	3100	25 kg	2323	2353
GR2AHL-66D	5	1765 mm	3420	30 kg	2469	2499
GR2AHL-72D	6	1918 mm	3810	34 kg	2667	2697
GR2AHL-84D	7	2223 mm	4520	37 kg	2930	2970

• When no color is specified, color inset panels and corner caps will be black – Non-standard colors are non-returnable.

◇ Does not include Remote Control Enclosure (RMB).

○ Does not include Remote Control Enclosure (RMB). Must choose RMB (see page 74).

‡ Available with CE Mark, add \$20 (see specifics below).

GR2AL-18D through -84D available with CE mark.

GR2AHL-18D through -84D available with CE mark (GR2AHL-72D, -84D require Remote Control Enclosure (RMB), see page 74).

**All Glo-Ray Designer Aluminium Dual Infrared with Lights Models Feature:**

Voltage: 220 or 240, single phase.

Switch Location: Remote only (see page 74).

Leads: 1524 mm leads through ½" conduit in leg cavity.

Dimensions: with 76 mm Spacer (Standard): 546-2223 W x 457 D x 89 H mm.

with 152 mm Spacer: 546-2223 W x 533 D x 89 H mm.

**OPTIONS AND ACCESSORIES – PAGE 68**

**RECOMMENDED MOUNTING HEIGHTS – PAGE 72**

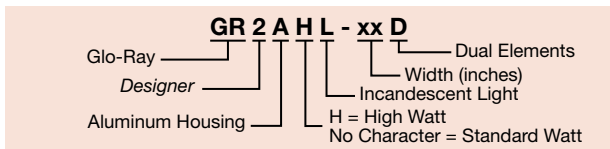



GR2AHL-30D

**OPTIONS** (available at time of purchase only)

**Designer Colors, aluminum models 546-2223 mm – includes stands – Non-standard colors are non-returnable – Clear Anodized Standard –**

<b>COLOR-15, -18</b>	381 mm and 457 mm Housings for GR2A, GR2AH, GR2AL and GR2AHL Dual models	per 305 mm	\$36
<b>RED</b>	Warm Red		
<b>BLACK</b>	Black		
<b>GRAY</b>	Gray Granite		
<b>WHITE</b>	White Granite		
<b>NAVY</b>	Navy Blue		
<b>GREEN</b>	Hunter Green		
<b>COPPER</b>	Antique Copper		

**Designer Inset Panel colors – Non-standard colors are non-returnable – Black Standard –** No Charge

<b>RED</b>	Warm Red	<b>WHITE</b>	White Granite	<b>GREEN</b>	Hunter Green
<b>GRAY</b>	Gray Granite	<b>NAVY</b>	Navy Blue	<b>COPPER</b>	Antique Copper

**Designer Corner Caps – Non-standard colors are non-returnable – Black Standard –** No Charge

<b>DKGRAY</b>	Dark Gray Corner Caps		
---------------	-----------------------	--	--

**RMB** Remote Control Enclosure (required) see page 74 for models and prices

**NO CONTROL** No Control included (GR2A-xxD, GR2AL-xxD, models only) – requires selection of RMB2-xx control (see page 74) No Charge

**Designer Remote Control Enclosures – Non-standard colors are non-returnable – Clear Anodized Standard –**

<b>RMB-COLOR</b>	Remote Control Enclosure Housing in Designer Color		\$ 36
<b>RED</b>	Warm Red	<b>GRAY</b>	Gray Granite
<b>BLACK</b>	Black	<b>WHITE</b>	White Granite
<b>NAVY</b>	Navy Blue	<b>GREEN</b>	Hunter Green
<b>COPPER</b>	Antique Copper		

**Sneeze Guards**

<b>7.5BP1</b>	191 mm Sneeze Guard - one side	per 305 mm	55
<b>7.5BP2</b>	191 mm Sneeze Guard - two sides	per 305 mm	110
<b>14BP1</b>	356 mm Sneeze Guard - one side	per 305 mm	89
<b>14BP2</b>	356 mm Sneeze Guard - two sides	per 305 mm	178

**NTL2-10, -12, -16** Designer Non-Adjustable Stands: 254, 305 or 406 mm in lieu of 356 mm Standard Legs  
Non-standard colors are non-returnable – No Charge

**NTH2-4** 102 mm Designer Overhead Mounts in lieu of 356 mm Standard Stands – Non-standard colors are non-returnable – No Charge

**NO BULB** No bulb option (GR2AL-xxD, GR2AHL-xxD models only) No Charge

**LIGHTS-ADD'L** Extra Lamps installed – max. two per 305 mm less one – one per 305 mm is Standard each 25

**Power Leads – Must specify lead length –**

<b>LEADS5</b>	305-1525 mm extended Electrical Leads	\$20
<b>LEADS10</b>	1829-3048 mm extended Electrical Leads	40
<b>LEADS15</b>	3352-4572 mm extended Electrical Leads	60
<b>LEADS20</b>	4877-6096 mm extended Electrical Leads	80

**COLORS AND FINISHES – INSIDE BACK COVER**



## Ultra-Glo® Aluminum Ceramic Infrared Strip Heaters

Hatco Ultra-Glo Aluminum Ceramic Strip Heaters provide the ultimate holding power. Increased heights improve working clearances and the heat zone blankets the entire holding area. All models include adjustable angle brackets for mounting. Available with or without lights, with attached or the recommended Remote Control Box Enclosure (RMB).



**UGAH-18** with optional Gloss Finish (requires Remote Control Enclosure (RMB) – not shown)

- Pre-focused pyramidal heat pattern, concentrates the heat at the edges where heat loss is the greatest
- Increased height improves operational working clearances, giving the chef and server an improved ergonomic working environment
- Adaptable to many locations and configurations, including back-or front-of-the-house use, open kitchen concepts or buffet lines
- Optional, coated shatter-resistant, incandescent bulbs enhance product displays, while safeguarding food from bulb breakage

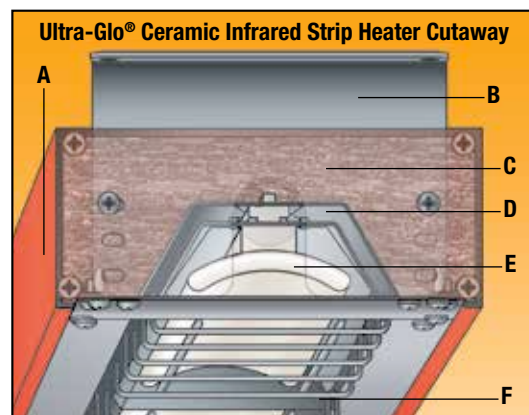

- A** Sturdy aluminum housings that do not sag, widths from 457 up to 1829 mm in 152 mm increments
- B** Adjustable Standard mounting bracket (allows three different mounting heights and allows for conduit connection to end of the unit)
- C** Heavy-duty insulation surrounds heating element to keep exterior housing cooler and minimize heat loss
- D** Dual aluminized steel reflector keeps housing cooler, focuses more heat towards the food
- E** Shape of element focuses the heat on the food
- F** Protective wire guard supports heating element without affecting heat distribution

Strip Heaters

### ULTRA-GLO ALUMINUM CERAMIC INFRARED STRIP HEATERS

Model*	Width	Watts		Ship Weight <sup>◇</sup>	List Price
		220V	240V		
<b>Standard Watt</b>					
UGA-18	457 mm	546	500	4 kg	\$ 615
UGA-24	610 mm	630	650	5 kg	624
UGA-30	762 mm	756	900	6 kg	753
UGA-36	914 mm	1092	1000	7 kg	758
UGA-42	1067 mm	1260	1200	8 kg	885
UGA-48	1219 mm	1638	1500	9 kg	894
UGA-54	1372 mm	1638	1500	9 kg	1011
UGA-60	1524 mm	2185	2000	10 kg	1023
UGA-66	1676 mm	2185	2000	11 kg	1144
UGA-72	1829 mm	2520	2000	11 kg	1169
<b>High Watt</b>					
UGAH-18	457 mm	630	650	5 kg	\$ 623
UGAH-24	610 mm	756	750	4 kg	632
UGAH-30	762 mm	945	1125	5 kg	761
UGAH-36	914 mm	1260	1300	7 kg	766
UGAH-42	1067 mm	1680	1500	7 kg	893
UGAH-48	1219 mm	1890	1950	9 kg	902
UGAH-54	1372 mm	2268	2250	9 kg	1019
UGAH-60	1524 mm	2520	2600	11 kg	1031
UGAH-66	1676 mm	2520	2600	10 kg	1152
UGAH-72	1829 mm	3025	3000	11 kg	1177

### ULTRA-GLO ALUMINUM CERAMIC INFRARED STRIP HEATERS with LIGHTS

Model* ♦	No. of Bulbs	Width	Watts		Ship Weight <sup>◇</sup>	List Price
			220V	240V		
<b>Standard Watt</b>						
UGAL-18	1	457 mm	596	560	5 kg	\$ 755
UGAL-24	2	610 mm	730	770	5 kg	769
UGAL-30	2	762 mm	856	1020	7 kg	925
UGAL-36	3	914 mm	1242	1180	9 kg	963
UGAL-42	3	1067 mm	1410	1380	10 kg	1109
UGAL-48	4	1219 mm	1838	1740	10 kg	1148
UGAL-54	4	1372 mm	1838	1740	12 kg	1297
UGAL-60	5	1524 mm	2434	2300	14 kg	1347
UGAL-66	5	1676 mm	2434	2300	14 kg	1483
UGAL-72	6	1829 mm	2820	2360	15 kg	1532
<b>High Watt</b>						
UGAHL-18	1	457 mm	680	710	5 kg	\$ 763
UGAHL-24	2	610 mm	856	870	5 kg	777
UGAHL-30	2	762 mm	1045	1245	8 kg	933
UGAHL-36	3	914 mm	1410	1480	8 kg	971
UGAHL-42	3	1067 mm	1830	1680	9 kg	1117
UGAHL-48	4	1219 mm	2090	2190	10 kg	1156
UGAHL-54	4	1372 mm	2468	2490	11 kg	1305
UGAHL-60	5	1524 mm	2770	2900	12 kg	1355
UGAHL-66	5	1676 mm	2770	2900	14 kg	1491
UGAHL-72	6	1829 mm	3324	3360	15 kg	1540

- \* CE Mark not available.
- ◇ Does not include Remote Control Enclosure (RMB).
- ♦ Models with Lights pricing includes RMB-UGA, unit can also be supplied with no switches.

**All Ultra-Glo Aluminum Ceramic Infrared Models Feature:**

Voltage: 220, 240, single phase.  
 Models Shipped with: Angle Brackets and 152 mm Leads.  
 Dimensions with Attached Remote Control Enclosure (RMB), Toggle and Indicator Light:  
 457-1829 W x 251 D x 64 H mm.  
 Dimensions with Remote Control Enclosure (RMB), Toggle and Indicator Light:  
 457-1829 W x 152 D x 64 H mm.  
 Contact factory for stainless marine applications.

**OPTIONS AND REMOTE CONTROL ENCLOSURES (RMB) – PAGE 71**  
**RECOMMENDED MOUNTING HEIGHTS – PAGE 72**

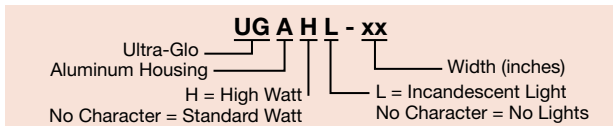

## Ultra-Glo® Aluminum Ceramic Dual Infrared Strip Heaters

Hatco Ultra-Glo Aluminum Ceramic Dual Infrared Strip Heaters provide the ultimate holding power. Increased height improves working clearances and the heat zone blankets the entire holding area. All models include adjustable angle brackets for mounting. Dual mounted strip heaters accommodate wider food holding areas.

- Increased height that the ceramic heat source affords improves operational working clearances, giving the chef and server an improved ergonomic environment in which to work
- Adaptable to any location and configuration including back- or front-of-the-house use, open kitchen concepts or buffet lines
- Sturdy continuous aluminum housings eliminate sagging
- Available in widths from 457 to 1829 mm
- Pre-focused heat pattern provides an increased pyramidal dimension, concentrating heat at the edges where heat loss is the greatest

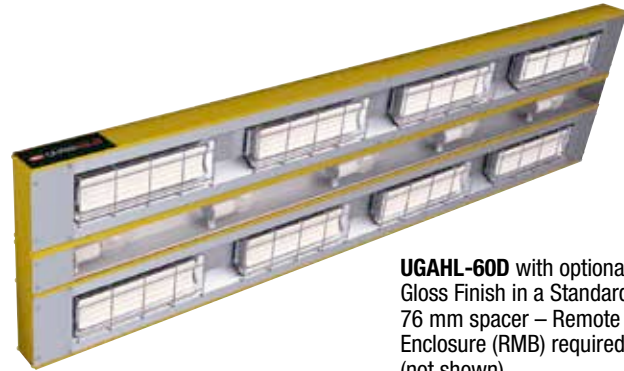

**UGAHL-60D** with optional Gloss Finish in a Standard 76 mm spacer – Remote Control Enclosure (RMB) required (not shown)

Strip Heaters

### ULTRA-GLO ALUMINUM CERAMIC DUAL INFRARED STRIP HEATERS

Model*	Width	Watts		Ship Weight <sup>◇</sup>	List Price
		220V	240V		
<b>Standard Watt</b>					
<b>UGA-18D</b>	457 mm	1092	1000	8 kg	<b>\$1222</b>
<b>UGA-24D</b>	610 mm	1260	1300	9 kg	<b>1274</b>
<b>UGA-30D</b>	762 mm	1512	1800	12 kg	<b>1547</b>
<b>UGA-36D</b>	914 mm	2184	2000	14 kg	<b>1596</b>
<b>UGA-42D</b>	1067 mm	2520	2400	15 kg	<b>1872</b>
<b>UGA-48D</b>	1219 mm	2520	3000	18 kg	<b>1920</b>
<b>UGA-54D</b>	1372 mm	2520	3000	19 kg	<b>2187</b>
<b>UGA-60D</b>	1524 mm	4368	4000	22 kg	<b>2247</b>
<b>UGA-66D</b>	1676 mm	4368	4000	23 kg	<b>2512</b>
<b>UGA-72D</b>	1829 mm	5040	4000	24 kg	<b>2590</b>
<b>High Watt</b>					
<b>UGAH-18D</b>	457 mm	1260	1300	8 kg	<b>\$1238</b>
<b>UGAH-24D</b>	610 mm	1512	1500	9 kg	<b>1290</b>
<b>UGAH-30D</b>	762 mm	1890	2250	11 kg	<b>1563</b>
<b>UGAH-36D</b>	914 mm	2520	2600	14 kg	<b>1612</b>
<b>UGAH-42D</b>	1067 mm	3360	3000	15 kg	<b>1888</b>
<b>UGAH-48D</b>	1219 mm	3780	3900	18 kg	<b>1936</b>
<b>UGAH-54D</b>	1372 mm	4536	4500	19 kg	<b>2203</b>
<b>UGAH-60D</b>	1524 mm	5040	5200	22 kg	<b>2263</b>
<b>UGAH-66D</b>	1676 mm	5040	5200	23 kg	<b>2528</b>
<b>UGAH-72D</b>	1829 mm	6048	6000	25 kg	<b>2606</b>

\* CE Mark, not available.

◇ Does not include Remote Control Enclosure (RMB).

◆ Models will be supplied without switches, remote switches are optional

#### All Ultra-Glo Aluminum Ceramic Dual Infrared Models Feature:

Voltage: 220, 240, single phase.

Models Shipped with: Angle Brackets and 152 mm Leads.

Dimensions with Attached Control Box, Toggle and Indicator Light: 457-1829 W x 479 D x 64 H mm.

Dimensions with Remote Control Enclosure (RMB), Toggle and Indicator Light: 457-1829 W x 381 D x 64 H mm.

### OPTIONS AND REMOTE CONTROL ENCLOSURES (RMB) – PAGE 71 RECOMMENDED MOUNTING HEIGHTS – PAGE 72

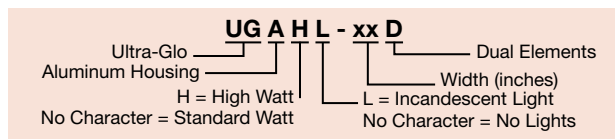

### ULTRA-GLO ALUMINUM CERAMIC DUAL INFRARED STRIP HEATERS with LIGHTS

Model* ◆	No. of Bulbs	Width	Watts		Ship Weight <sup>◇</sup>	List Price
			220V	240V		
<b>Standard Watt</b>						
<b>UGAL-18D</b>	1	457 mm	1142	1060	8 kg	<b>\$1281</b>
<b>UGAL-24D</b>	2	610 mm	1360	1420	10 kg	<b>1307</b>
<b>UGAL-30D</b>	2	762 mm	1612	1920	12 kg	<b>1629</b>
<b>UGAL-36D</b>	3	914 mm	2334	2180	14 kg	<b>1701</b>
<b>UGAL-42D</b>	3	1067 mm	2670	2580	16 kg	<b>2003</b>
<b>UGAL-48D</b>	4	1219 mm	2720	3240	14 kg	<b>2065</b>
<b>UGAL-54D</b>	4	1372 mm	2666	3240	19 kg	<b>2362</b>
<b>UGAL-60D</b>	5	1524 mm	4618	4300	23 kg	<b>2430</b>
<b>UGAL-66D</b>	5	1676 mm	4618	4300	23 kg	<b>2717</b>
<b>UGAL-72D</b>	6	1829 mm	5340	4360	25 kg	<b>2815</b>
<b>High Watt</b>						
<b>UGAHL-18D</b>	1	457 mm	1310	1360	8 kg	<b>\$1297</b>
<b>UGAHL-24D</b>	2	610 mm	1612	1620	7 kg	<b>1323</b>
<b>UGAHL-30D</b>	2	762 mm	1990	2370	11 kg	<b>1645</b>
<b>UGAHL-36D</b>	3	914 mm	2670	2780	12 kg	<b>1717</b>
<b>UGAHL-42D</b>	3	1067 mm	3510	3180	15 kg	<b>2019</b>
<b>UGAHL-48D</b>	4	1219 mm	3980	4140	16 kg	<b>2081</b>
<b>UGAHL-54D</b>	4	1372 mm	4736	4740	20 kg	<b>2378</b>
<b>UGAHL-60D</b>	5	1524 mm	5290	5500	22 kg	<b>2446</b>
<b>UGAHL-66D</b>	5	1676 mm	5290	5500	23 kg	<b>2733</b>
<b>UGAHL-72D</b>	6	1829 mm	6348	6360	26 kg	<b>2831</b>



**UGAH-42D** with Standard 76 mm spacer – Remote Control Enclosure (RMB) recommended (not shown)

Strip Heaters

**OPTIONS** (available at time of purchase only)

**Designer Colors, aluminum models 457-1829 mm – Non-standard colors are non-returnable – Clear Anodized Standard –**

<b>COLOR-6</b>	152 mm Housing for Single UGA and UGAH models (Designer Color selection below)	per 305 mm	<b>\$25</b>
<b>COLOR-9</b>	229 mm Housing for Single UGAL and UGAHL models (Designer Color selection below)	per 305 mm	<b>25</b>
<b>COLOR-15</b>	381 mm Housing for Dual UGA, UGAH, UGAL, UGAHL (Designer Color selection below)	per 305 mm	<b>36</b>
	<b>RED</b> Warm Red <b>GRAY</b> Gray Granite <b>NAVY</b> Navy Blue <b>COPPER</b> Antique Copper		
	<b>BLACK</b> Black <b>WHITE</b> White Granite <b>GREEN</b> Hunter Green		

**Gloss Finishes, aluminum models 457-1829 mm – Non-standard colors are non-returnable – Clear Anodized Standard –**

<b>GLOSS-6</b>	152 mm Housing for Single UGA and UGAH models (Gloss Finish selection below)	per 305 mm	<b>\$34</b>
<b>GLOSS-9</b>	229 mm Housing for Single UGAL and UGAHL models (Gloss Finish selection below)	per 305 mm	<b>34</b>
<b>GLOSS-15</b>	381 mm Housing for Dual UGA, UGAH, UGAL, UGAHL models (Gloss Finish selection below)	per 305 mm	<b>46</b>
	<b>RRED</b> Radiant Red <b>GGRAY</b> Glossy Gray <b>BBLACK</b> Bold Black		
	<b>GGOLD</b> Gleaming Gold <b>BBLUE</b> Brilliant Blue		

**Designer Colors, Remote Control Enclosures – Non-standard colors are non-returnable – Clear Anodized Standard –**

<b>RMB-COLOR</b>	Remote Control Enclosure Housing in Designer Color		<b>36</b>
	<b>RED</b> Warm Red <b>GRAY</b> Gray Granite <b>NAVY</b> Navy Blue <b>COPPER</b> Antique Copper		
	<b>BLACK</b> Black <b>WHITE</b> White Granite <b>GREEN</b> Hunter Green		

**Gloss Finishes, Remote Control Enclosures – Non-standard colors are non-returnable – Clear Anodized Standard –**

<b>RMB-GLOSS</b>	Remote Control Enclosure Housing in Gloss Finish		<b>\$ 52</b>
	<b>RRED</b> Radiant Red <b>GGRAY</b> Glossy Gray <b>BBLACK</b> Bold Black		
	<b>GGOLD</b> Gleaming Gold <b>BBLUE</b> Brilliant Blue		

<b>LIGHTS-ADD'L</b>	Extra Lamps installed (max. two per 305 mm less one), one per 305 mm is Standard – Not available for Dual models	each	<b>25</b>
---------------------	--	------	-----------

**Stands**

<b>UGA-NTL-14, -16</b>	Non-Adjustable Tubular Stands – specify 356 or 406 mm clearance	1 pair	<b>95</b>
<b>UGA-NTL-18, -20</b>	Non-Adjustable Tubular Stands – specify 457 or 508 mm clearance	1 pair	<b>101</b>
<b>UGA-NTL-22, -24</b>	Non-Adjustable Tubular Stands – specify 559 or 610 mm clearance	1 pair	<b>109</b>
<b>UGA-NTL-18-D, -20-D</b>	Non-Adjustable Tubular Stands – specify 457 or 508 mm clearance	2 pair	<b>202</b>
<b>UGA-NTL-22-D, -24-D, -26-D</b>	Non-Adjustable Tubular Stands – specify 559, 610 or 660 mm clearance	2 pair	<b>218</b>
<b>NTL-PAINT</b>	Designer Color or Gloss Finish to match unit color for Non-Adjustable Tubular Stands – Non-standard colors are non-returnable –	1 pair	<b>36</b>
<b>NTL-PAINT-D</b>	Designer Color or Gloss Finish to match unit color for Non-Adjustable Tubular Stands – Non-standard colors are non-returnable –	2 pair	<b>72</b>

**Power Leads – Extend beyond Standard 914 mm conduit (must specify lead length) –**

<b>HTLEADS5</b>	305-1525 mm extended Electrical Leads		<b>\$ 30</b>
<b>HTLEADS10</b>	1829-3048 mm extended Electrical Leads		<b>60</b>
<b>HTLEADS15</b>	3352-4572 mm extended Electrical Leads		<b>90</b>
<b>HTLEADS20</b>	4877-6096 mm extended Electrical Leads		<b>120</b>

<b>RMB-UGA</b>	Remote Control Enclosure with Toggle Control and Indicator in lieu of attached control box – not available on Dual models Designer Color and Gloss Finish available – Non-standard colors are non-returnable –		<b>No Charge</b>
----------------	---	--	------------------

<b>RMB-UGA-INF</b>	Remote Control Enclosure with Toggle Switch, Electronic Infinite Control, Relay and Indicator Light in lieu of attached control box – Not available for 240V with lights – Designer Colors and Gloss Finishes available – Non-standard colors are non-returnable –		<b>\$338</b>
--------------------	--	--	--------------

**COLORS AND FINISHES – INSIDE BACK COVER**

**RMB-UGA-INF**





## Strip Heater Recommended Range Above Target\* and Spacing Requirements (based on 610 mm strip heaters, non-flammable surface)

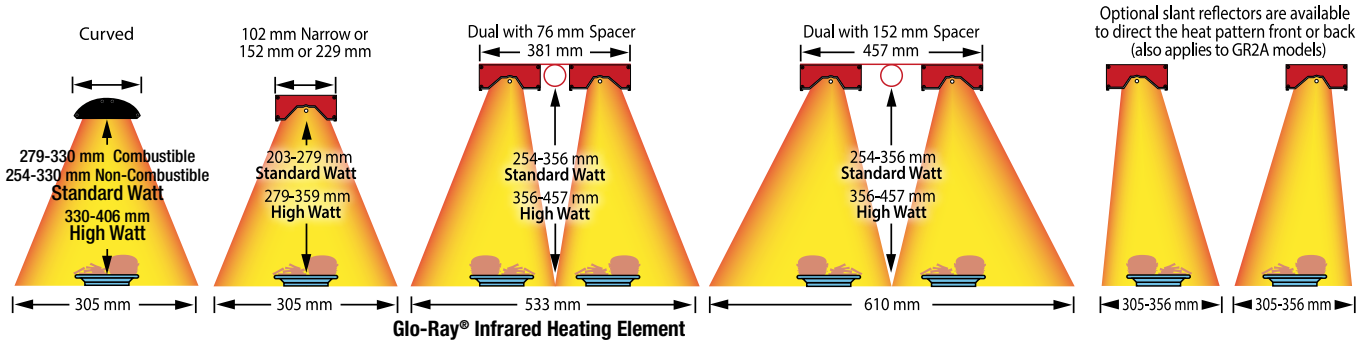

### GLO-RAY® INFRARED

#### Curved Standard Watt (GR5A, (GR5AH, GR5AL, GR5AHL)

Minimum combustible surface: Install a minimum of 26 mm from back wall, 26 mm from oversheff and 279 mm above surface.

Minimum non-combustible surface: 26 mm from oversheff and 254 mm above surface (back of wall: no requirement).

#### Curved High Watt (GR5AH, GR5AHL)

Non-combustible surroundings only. Install 26 mm from oversheff and minimum of 330 mm above a non-combustible countertop surface (back of wall: no requirement).

#### Singles (GRA, GRAL, GRAH, GRAHL, GRN)

#### Singles Designer (GR2A, GR2AH, GR2AL, GR2AHL)

Combustibles: 343 mm high watt or 254 mm standard watt below, 25 mm above and 76 mm to back wall.

Non-combustibles: 25 mm above, 254 mm below for high watt with infinite or indicator lamp and 203 mm below for high watt toggle or standard watt. Must be installed in a pass-through area. Units with remote switches may be installed against a non-combustible back wall, flush to an oversheff and 203 mm to a surface below. Maximum 254 mm setback from the front of an oversheff.

Models with cords must be installed 76 mm below an oversheff and 279 mm high watt or 254 mm standard watt over a surface below.

#### Duals (GRA-D, GRAH-D, GRAL-D, GRAHL-D)

#### Duals Designer (GR2A-D, GR2AH-D, GR2AL-D, GR2AHL-D)

May not be installed in combustible surroundings.

Non-combustibles: 25 mm above, 254 mm below. Must be installed in a pass-through area. Units with remote switches may be installed 76 mm from a non-combustible back wall, 203 mm from surface below and flush to an oversheff. Maximum 254 mm setback from the front of an oversheff.

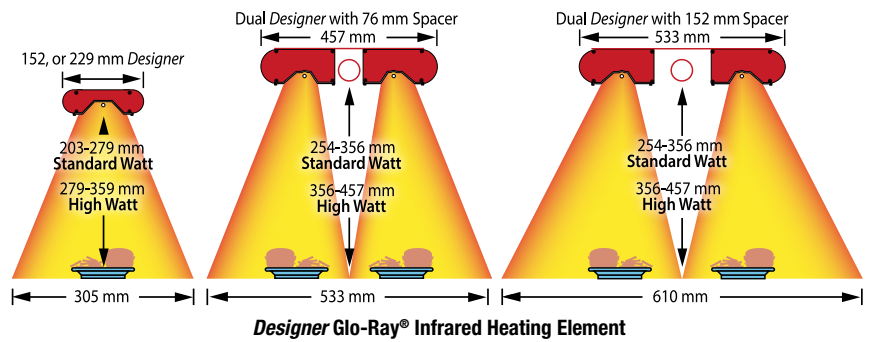

### ULTRA-GLO®

#### Singles and Duals (UGA, UGA-D, UGAH, UGAH-D, UGAL, UGAL-D, UGAHL, UGAHL-D)

May not be installed in combustible surroundings.

Non-combustibles: 25 mm above, 432 mm high watt or 356 mm standard watt from a surface below and 76 mm from a back wall.

**Dual Mounting** Do not mount warmers side by side (dual mounting) with less than a 76 mm space between units.

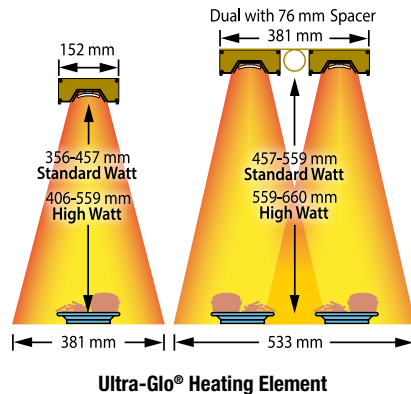

### GLO-RAY® INFRA-BLACK®

#### (GRAIH, GRAIHL, GRAIHL-D, GRAIH-D)

May not be installed in combustible surroundings.

Non-combustibles: 25 mm above and 102 mm below. Must be installed in a pass-through area. Units with remote switches may be installed 76 mm from a non-combustible back wall and flush to an oversheff. Maximum 254 mm setback from the front of an oversheff.

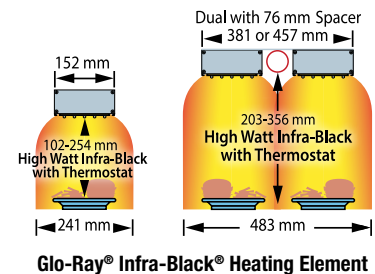

\* Recommended single unit application without base heat, based on ideal conditions. Based on a 610 mm Strip Heater. Individual applications may vary, consult factory.



## Mounting Arrangements

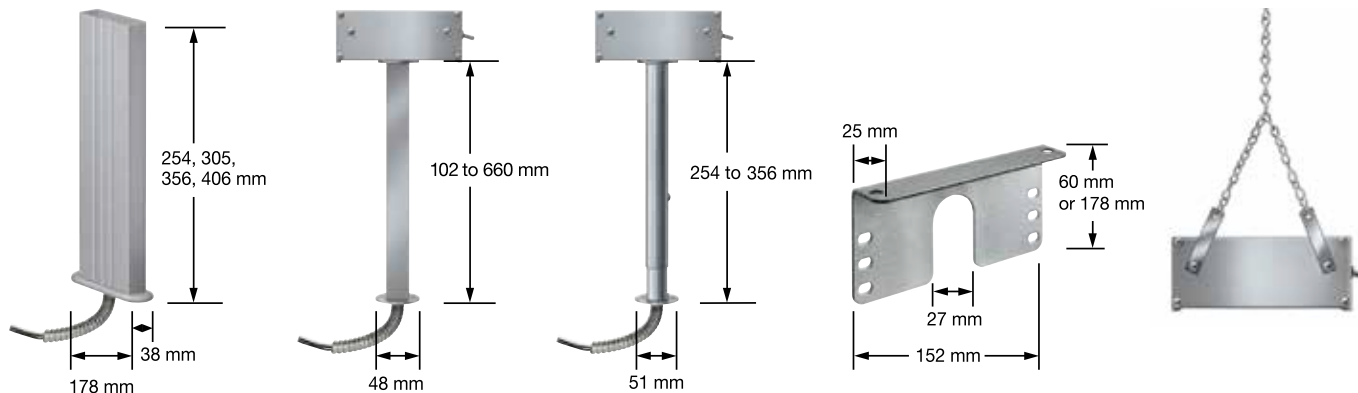

### PERMANENT - FOR HARD WIRED INSTALLATION

#### Designer Non-Adjustable Stands

(GR2A series only) Sturdy stands conceal all hook-up wiring. Available in Designer colors.

#### Non-Adjustable Tubular Stands

Sturdy stands conceal all hook-up wiring. Available in Designer Colors. Duals require two pair. Specify bottom power location.

#### Adjustable Tubular Stands

Sturdy tubular stands conceal all hook-up wiring. Duals require two pair (not available on Ultra-Glo® models). Specify bottom power location.

#### Angle brackets

Special adjustable angle brackets fit 152 or 229 mm housings for mounting Glo-Ray under a shelf. Provides 25-51 mm space or 25 - 152 mm space between Glo-Ray and overself. Duals require two pair. (Standard on Ultra-Glo models).

#### Chain Suspension

Chains attach to tabs provided with warmers and are available in various lengths to suit the location (not available on Ultra-Glo models).

Strip Heaters

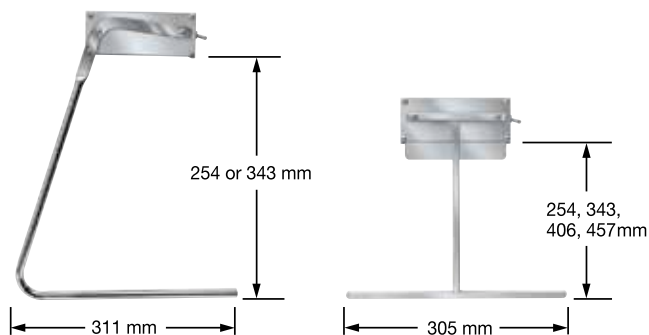

### PORTABLE

#### C-Leg Stands

Attractive chrome plated legs allow easy relocation of the warmer. For models 1829 mm or less in width (not available on Ultra-Glo models).

#### T-Leg Stands

Provide rigid stability and allow for more pass-through area below unit. For models 1829 mm or less in width (not available on Ultra-Glo models).

### STATIONARY

#### Chain Hook

Chains attach to tabs provided with warmers. 152 mm chain with S-Hooks for units.

## Remote Control Enclosures (RMB)

Hatco Remote Control Enclosures (RMB) are built with toggle or infinite switches, indicator lights and wiring, ready for installation when purchased with Glo-Ray® Strip Heaters.

- Built for toggle or infinite switches, indicator lights and wiring
- Threaded rubber boot for toggle switch is Standard
- One RMB per Strip Heater (except RMB2 units)



**RMB-14**  
with infinite controls



**RMB-7** with toggle switch and infinite control



**RMB-3** with toggle switch and indicator light



**RMB-7** with toggle switches and optional *Designer* Color

Strip Heaters

### REMOTE CONTROL ENCLOSURES (RMB)

Model	Description	Width	List Price	
			Non-CE	CE †
<b>RMB-3</b>	1 toggle switch	140 mm	<b>\$132</b>	<b>\$142</b>
	2 toggle switches	140 mm	<b>150</b>	<b>157</b>
	1 toggle switch, 1 indicator light	140 mm	<b>150</b>	<b>157</b>
	1 infinite switch	140 mm	<b>150</b>	<b>187</b>
<b>RMB-7</b>	3 toggle switches	229 mm	<b>\$185</b>	<b>\$210</b>
	4 toggle switches	229 mm	<b>217</b>	<b>-</b>
	2 toggle switches, 2 indicator lights	229 mm	<b>199</b>	<b>208</b>
	1 toggle switch, 1 infinite switch	229 mm	<b>183</b>	<b>224</b>
	1 toggle switch, 1 infinite switch 1 indicator light	229 mm	<b>202</b>	<b>239</b>
	2 infinite switches	229 mm	<b>202</b>	<b>283</b>
<b>RMB-14</b>	1 infinite switch, 1 indicator light	229 mm	<b>180</b>	<b>218</b>
	4 toggle switches	356 mm	<b>-</b>	<b>\$226</b>
	5 toggle switches	356 mm	<b>\$274</b>	<b>-</b>
	6 toggle switches	356 mm	<b>323</b>	<b>-</b>
	3 toggle switches, 3 indicator lights	356 mm	<b>-</b>	<b>255</b>
	2 toggle switches, 2 infinite switches	356 mm	<b>284</b>	<b>334</b>
	1 toggle switch, 2 infinite switches	356 mm	<b>248</b>	<b>330</b>
	4 infinite switches	356 mm	<b>319</b>	<b>460</b>
<b>RMB2-1R</b>	2 infinite switches, 2 indicator lights	356 mm	<b>256</b>	<b>327</b>
	4 infinite switches, 1 toggle switch	406 mm	<b>319</b>	<b>-</b>
	1 toggle, 1 infinite, 1 relay, 1 indicator	280 mm	<b>\$684</b>	<b>-</b>

† CE models require any remote switches be contained in a Remote Control Enclosure (RMB).

**All Models Feature:**

Voltage: 220 or 240, single phase.

Ship Weight: 1-3 kg depending on components.

Max. Allowable Amperage per Switch: Toggle: 15.0

Infinite: 12.2

RMB2-1R: 16 or 20

Dimensions (not including switches): 140, 229, 356 or 406 W x 76 D x 64 H mm.

RMB2-1R: 280 W x 115 D x 140 H mm.

RMB2-1R Cutout Dimensions: 258 W x 121 H mm.

**Toggle Switch:** Max. 15 Amps  
**Infinite Switch:** Max. 12.2 Amps

**Remote Control Enclosures (RMB):**  
When used, no more than one RMB per Strip heater and no more than one Strip Heater per RMB (except RMB2 units).

"Choose Remote Box" (RMB) can be found on:  
[www.hatcocorp.com](http://www.hatcocorp.com)  
under "Resources"

### OPTIONS (available at time of purchase only)

**Designer Colors (not available for RMB2-1R) – Non-standard colors are non-returnable –**

<b>RMB-COLOR</b>	Remote Control Enclosure Housing in <i>Designer</i> Color						<b>\$36</b>
	<b>RED</b> Warm Red	<b>GRAY</b> Gray Granite	<b>NAVY</b> Navy Blue	<b>COPPER</b> Antique Copper			
	<b>BLACK</b> Black	<b>WHITE</b> White Granite	<b>GREEN</b> Hunter Green				

**Gloss Finishes (not available for RMB2-1R) – Non-standard colors are non-returnable –**

<b>RMB-GLOSS</b>	Remote Control Enclosure Housing in Gloss Finish						<b>52</b>
	<b>RRED</b> Radiant Red	<b>GGRAY</b> Glossy Gray	<b>BBLACK</b> Bold Black				
	<b>GGOLD</b> Gleaming Gold	<b>BBLUE</b> Brilliant Blue					

### COLORS AND FINISHES – INSIDE BACK COVER

# Fry Stations

*Supermarkets & Delis*  
*Restaurants & Cafés • Clubs & Bars*



**GRFF** in optional Brilliant Blue Gloss finish and **UGFF** in optional Glossy Gray Gloss finish *pg. 76*



**GRFFL** with optional 229 mm display sign holder (sign not included) and *Designer Warm Red* color and accessory food pan *pg. 76*



**GRFHS-PT26** with accessory fry box ribbon *pg. 79*



**GRFHS-PT26** with accessory 8-pleat hardcoated fry box ribbon (scoop not included) *pg. 79*



**GRFHS-PTT21** *pg. 79*



**GRFSC-18** with swing-away post mount, cord with plug and accessory food pan *pg. 79*

## Portable Foodwarmers

Opt for the versatility of Hatco's Glo-Ray® and Ultra-Glo® Portable Foodwarmers. With heat from above, below or both, these foodwarmers offer design flexibility without sacrificing food product quality. Ideal for use next to fry stations, drive-through windows and service areas that require frequent and easy access.

- Portable – ready to plug in and use
- Versatile – available in many sizes, styles and heat sources to fit your needs
- Flexible – both top and bottom heat available
- Available with incandescent bulbs containing special protective coating to guard against food contamination
- Ceramic heating elements provide more distance between the heat source and the holding pan (UGFF series only)
- Toggle switch is standard; infinite switch optional on GRFF series
- All base heat units (GR-B, GRFFB and UGFFB) have a preset automatic thermostat to maintain consistent temperatures



GR-B Heated Base with accessory sheet pan

GRFFB with optional infinite switch and accessory food pans



UGFFL in optional Radiant Red Gloss finish with accessory fry ribbon and food pan



Fry Stations

### GLO-RAY® PORTABLE FOODWARMERS

Model †	Dimensions W x D x H	Watts		Ship Weight	List Price
		220V	240V		
GR-B	324 x 559 x 57 mm	250	250	6 kg	\$521
GRFF	314 x 610 x 400 mm	500	500	6 kg	530
GRFFL	314 x 610 x 400 mm	600	620	6 kg	678
GRFFB§	324 x 610 x 406-508 mm	710	750	13 kg	840
GRFFBL§	324 x 610 x 406-508 mm	810	870	14 kg	993

† Available with CE Mark, add \$15.

§ Standard clearance is 356 mm. Specify 305 or 406 mm if required.

#### All Portable Foodwarmers Feature:

Models Shipped With: 1829 mm cord and plug.

Cord Location: GR-B, GRFFB, GRFFBL: Back, lower middle.

GRFF, GRFFL: Back, upper middle.

### OPTIONS AND ACCESSORIES – PAGE 77

### ULTRA-GLO® PORTABLE FOODWARMERS WITH CERAMIC ELEMENTS

Model †	Dimensions W x D x H	Watts		Ship Weight	List Price
		220V	240V		
UGFF	314 x 565 x 479 mm	630	750	7 kg	\$ 660
UGFFL	314 x 565 x 479 mm	730	870	8 kg	813
UGFFB	324 x 572 x 559 mm	840	1000	11 kg	990
UGFFBL	324 x 572 x 559 mm	940	1120	15 kg	1145

† Available with CE Mark, add \$15.

#### All Portable Foodwarmers with Ceramic Elements Feature:

Models Shipped With: 1829 mm cord and plug.

Cord Location: UGFF, UGFFL: Back, upper middle.

UGFFB, UGFFBL: Back, lower middle.

### OPTIONS AND ACCESSORIES – PAGE 77

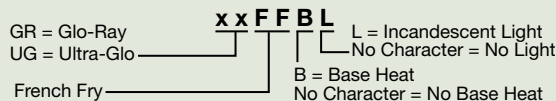





UGFFB with accessory food pan (perforated pans not available)

Fry Stations

**OPTIONS** (available at time of purchase only)

*Designer colors (one color per unit, heated base is not powdercoated, not available for GR-B models)*

*Non-standard colors are non-returnable – Clear Anodized standard –*

<b>RED</b>	Warm Red	<b>\$118</b>
<b>BLACK</b>	Black	<b>118</b>
<b>GRAY</b>	Gray Granite	<b>118</b>
<b>WHITE</b>	White Granite	<b>118</b>
<b>NAVY</b>	Navy Blue	<b>118</b>
<b>GREEN</b>	Hunter Green	<b>118</b>
<b>COPPER</b>	Antique Copper	<b>118</b>

*Gloss finishes (one color per unit, heated base is not painted, not available for GR-B models)*

*Non-standard colors are non-returnable –*

<b>RRED</b>	Radiant Red	<b>\$164</b>
<b>GGOLD</b>	Gleaming Gold	<b>164</b>
<b>GGRAY</b>	Glossy Gray	<b>164</b>
<b>BBLUE</b>	Brilliant Blue	<b>164</b>
<b>BBLACK</b>	Bold Black	<b>164</b>

*Clearance (from bottom of Glo-Ray to top of heated surface – GRFFB, GRFFBL only – 356 mm standard)*

<b>305 mm</b>	<b>No Charge</b>
<b>356 mm</b>	<b>Standard</b>
<b>406 mm</b>	<b>No Charge</b>

<b>SIGN HOLD</b>	Sign Holder for GRFFL Model with Back Toggle only (requires 229 W x 140 H x 2 D mm sign, which is not included and adds 76 mm to height of unit)	<b>\$37</b>
<b>INF</b>	Infinite Control (not available on models GR-B, UGFF, UGFFL, UGFFB or UGFFBL)	<b>37</b>

**ACCESSORIES** (available for purchase at any time)

<b>5PLTBOX</b>	Five-Pleat Hardcoated French Fry Box Ribbon – 489 W x 235 D x 51 H mm	<b>\$180</b>
<b>8PLTBAG</b>	Eight-Pleat Hardcoated French Fry Bag Ribbon – 489 W x 235 D x 51 H mm	<b>180</b>

**FRY RIBBONS – PAGE 80**

**FOOD PANS AND TRIVETS – PAGE 177**

**COLORS AND FINISHES – INSIDE BACK COVER**

## Multi-Product Warming Stations

Hatco's redesigned Multi-Product Warming Station safely holds hot fried foods at optimum serving temperatures in kitchen work areas. The unit is designed for maximum durability and performance with minimum maintenance.

- New removable left/right side panel
- New wider, deeper side openings
- Easy access to food product
- Coated shatter-resistant incandescent lights enhance brilliant product display while safeguarding food from bulb breakage

- Thermostatically controlled base heat assures safe serving temperatures
- Six overhead ceramic heating elements are adjusted by two separate electronic infinite controls – one for the rear elements and one for the front elements
- All stainless steel construction
- Master On/Off rocker switch

### ENDLESS POSSIBILITIES OF CONFIGURATIONS

Incremental spacing between portable dividers is 130 mm



MPWS-36 with accessory angled risers, fry pan and trivet (plastic food pans not available)



Shown with accessory fry bin insert and standard detachable side panel on right side



Shown with optional fry pans, accessory fry ribbon on angled riser and accessory scoop holder



Shown with optional fry pans, and accessory angled riser and scoop holder (plastic food pans not available)



Shown with accessory fry ribbons on angled risers, fry pan and scoop holder (plastic food pans not available)

Fry Stations

### MULTI-PRODUCT WARMING STATIONS

Model*	No. of Bulbs	Dimensions W x D x H	Watts 230V	Ship Weight	List Price
MPWS-36	4	950 x 630 x 832 mm	3075	69 kg	\$4260
MPWS-45	4	1153 x 630 x 832 mm	3108	77 kg	4753

\* Not available with CE mark.

#### All Multi-Product Warming Stations Feature:

Models Shipped With: 102 mm adjustable legs, left/right side panel.

Cord Location: Back, upper left corner.

### OPTION CAPACITIES

Model	Fry Pan with Trivet	Angled Risers
MPWS-36	1	3
	2	1
	0	5
MPWS-45	1	4
	2	2
	0	6

### ACCESSORIES (available for purchase at any time)

FHS4BOX	Four-Pleat Hardcoated Fry Box Ribbon – 273 W x 127 D x 45 H mm	\$ 69
FHS5BAG	Five-Pleat Hardcoated Fry Bag Ribbon – 299 W x 127 D x 48 H mm	69
5BH	127 mm Side-by-Side Bag Holder	46
FHS-SH	Scoop Holder	46
MPWS-RISER	Angled Riser	92
MPWS-PT	Fry Pan and Trivet	404
MPWS36BIN	Full Fry Bin Insert for MPWS-36 unit only (includes Drip Tray, Perforated Insert and 3 Dividers)	each \$383
MPWS45BIN	Full Fry Bin Insert for MPWS-45 unit only (includes Drip Tray, Perforated Insert and 4 Dividers)	each 411

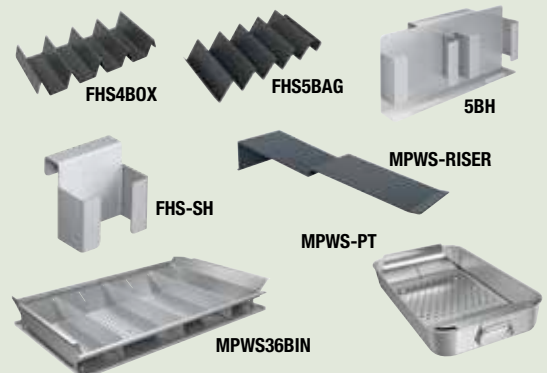

### FOOD PANS AND TRIVETS – PAGE 177

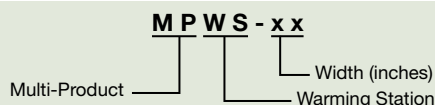

## Glo-Ray® Fry Stations

Hatco offers convenient Glo-Ray® Fry Stations that can be placed where they are most needed – next to a fryer! Glo-Ray heat technology offers the ability to keep fried foods at optimum temperatures, ready to serve, without cooking or drying them out.

- Various hardcoated fry ribbons stage boxed or bagged products for quick-service areas
- Thermostatically-controlled heated base maintains uniform holding temperatures from below (GRFHS series)
- Accessory hardcoated fry ribbons absorb more radiant heat than stainless steel and can be up to 8° to 11°C hotter (GRFHS series)
- Portable models including pass-through style (GRFHS series)
- Sectional divider permits holding of multiple products simultaneously (GRFHS series)
- GRFHS models have ceramic elements
- Fry Station Warmers (GRFSC, GRFS series) feature a built-in top heat source and a swing-away post mount
- GRFSC series available with ceramic heating element, while the GRFS series has metal sheathed or ceramic heating elements
- Variety of clearances (GRFS series)
- GRFS series has power toggle switch, cord and plug, plus optional infinite control

**GRFHS-21** with optional right-hand cutout for fry basket and accessory fry ribbon (left-hand cutout also available)



**GRFHS-PTT21**



**GRFHS-16**



**GRFSC-18**  
Swing-away post mount

### FRY HOLDING STATIONS

Model ‡	No. of Bulbs	Dimensions W x D x H	Watts		Ship Weight	List Price
			220V-230V	230V-240V		
GRFHS-16*	2	416 x 559 x 564 mm	1057-1155	1019-1110	23 kg	\$2665
GRFHS-21*	2	543 x 724 x 578 mm	1218-1332	1102-1200	29 kg	2928
GRFHS-26*	2	672 x 595 x 578 mm	1243-1359	1128-1229	30 kg	3007
GRFHS-PT16*	2	549 x 591 x 625 mm	1057-1155	1019-1110	27 kg	2640
GRFHS-PT26▲	2	759 x 570 x 625 mm	1233-1347	1347-1468	29 kg	3007
GRFHS-PT26▲■	2	759 x 570 x 625 mm	1233-1347	1347-1468	29 kg	3113
GRFHS-PTT21*	2	578 x 965 x 572 mm	1486-1624	1624-1768	45 kg	3057

‡ Available with CE Mark, at no added charge.

\* Add 44 mm to width if ordering Scoop Holder.

▲ Scoop Holder standard.

■ Includes a built-in 152 mm deep heated food holding base (102 mm is standard on all other models).

#### All Fry Holding Station Models Feature:

Models Shipped with: One slotted holding bin and one sectional divider.

Cord Location: GRFHS-16, -21, -26, -PT26: Back side, lower right corner.

GRFHS-PTT21: Lower right-hand side.

### FRY STATION WARMERS

Model ‡	No. of Bulbs	Dimensions W x D x H	Watts		Ship Weight	List Price
			220V	240V		
GRFSC-18 <sup>□</sup>	—	152 x 457 x 489-572 mm	630	750	5 kg	\$577
GRFSC-18 <sup>□</sup>	2	229 x 457 x 489-572 mm	730	870	6 kg	692
GRFSCR-18 <sup>□†</sup>	—	152 x 457 x 489-572 mm	630	750	5 kg	577
GRFSLR-18 <sup>□†</sup>	2	229 x 457 x 489-572 mm	730	870	6 kg	692
GRFS-24 <sup>□</sup>	—	152 x 610 x 318-394 mm	500	500	5 kg	471
GRFSL-24 <sup>□</sup>	2	229 x 610 x 318-394 mm	592	608	6 kg	594
GRFSR-24 <sup>□†</sup>	—	152 x 610 x 318-394 mm	500	500	5 kg	471
GRFSLR-24 <sup>□†</sup>	2	229 x 610 x 318-394 mm	600	620	6 kg	594

‡ Available with CE Mark, add \$15.

□ Specify clearance of 305, 425, 457 (standard) or 508 mm when ordering.

† Fry Station Warmer without cord and plug. Supply wires through mounting post.

□ Specify clearance of 254, 279, 305 or 330 (standard) mm when ordering.

#### All Fry Station Warmer Models Feature:

Toggle Switch Location: Ceramic Heating Element Models: Back of unit.

Metal Sheathed Heating Element Models: Front of unit.

Cord Location: GRFSC-18 and GRFSC-18: Back, right-hand side.

GRFS-24 and GRFSL-24: Back, upper middle.

### OPTIONS AND ACCESSORIES – PAGE 80



GRFS, GRFSL, GRFSC, GRFSC-18 with swing-away post mount and cord with plug.

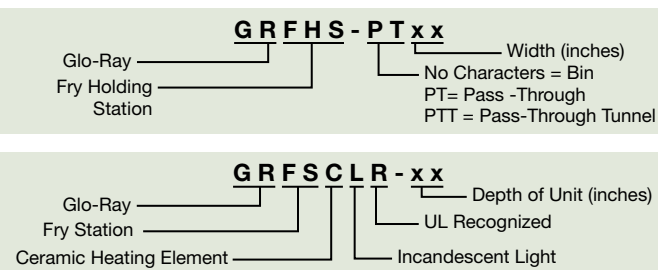



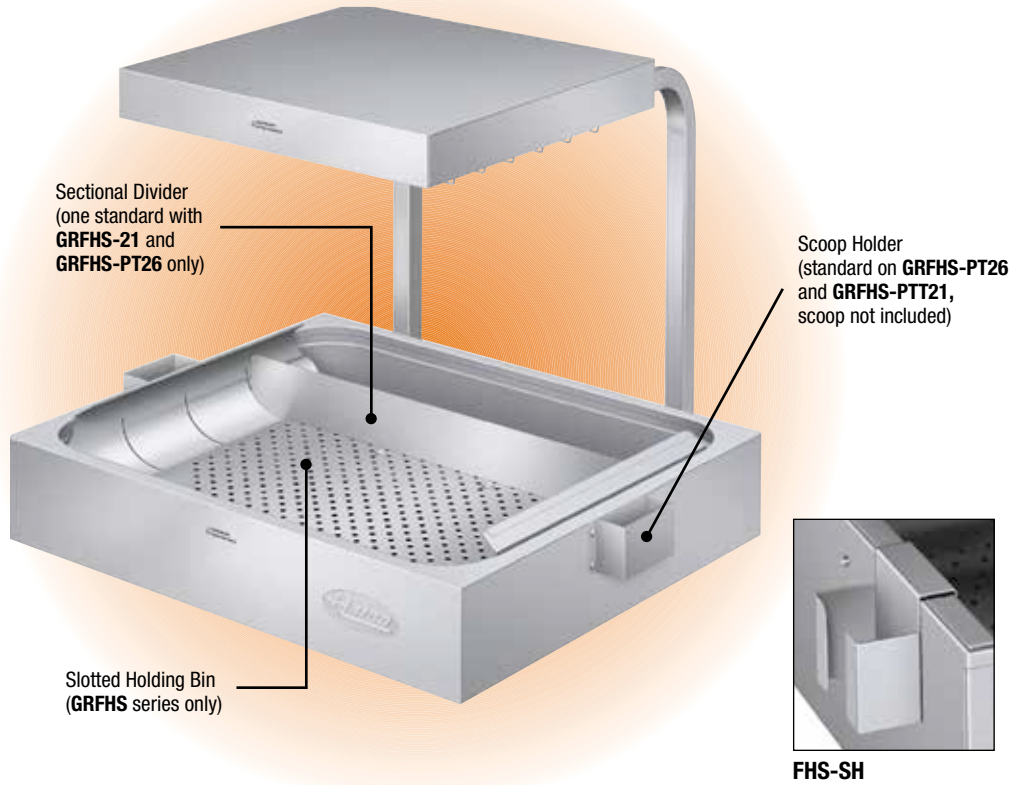

**OPTIONS** (available at time of purchase only)

<b>FHS-CUT</b>	Right- or Left-Hand Cutout for Fry Basket – must specify side at time of order – Adds 43 mm to width of unit (GRFHS-16, -21, -26 models only)	<b>No Charge</b>
<b>INF</b>	Infinite Control (metal sheathed GRFS models only)	<b>\$37</b>

**ACCESSORIES** (available for purchase at any time)

<b>5PLTBOX</b>	Five-Pleat Hardcoated French Fry Box Ribbon – 489 W x 235 D x 51 H mm	<b>\$180</b>
<b>8PLTBAG</b>	Eight-Pleat Hardcoated French Fry Bag Ribbon – 489 W x 235 D x 51 H mm	<b>180</b>
<b>FHS4BOX</b>	Four-Pleat Hardcoated Fry Box Ribbon (GRFHS-16 & -26) – 273 W x 127 D x 45 H mm	<b>69</b>
<b>FHS5BAG</b>	Five-Pleat Hardcoated Fry Bag Ribbon (GRFHS-16 & -26) – 286 W x 127 D x 48 H mm	<b>69</b>
<b>FHS5BOX</b>	Five-Pleat Hardcoated Fry Box Ribbon (GRFHS-21) – 445 W x 127 D x 48 H mm	<b>112</b>
<b>FHS7BAG</b>	Seven-Pleat Hardcoated Fry Bag Ribbon (GRFHS-21) – 454 W x 127 D x 48 H mm	<b>112</b>
<b>PT26-10BAG</b>	Ten-Pleat Hardcoated Fry Bag Ribbon (GRFHS-PT26) – 572 W x 127 D x 48 H mm	<b>139</b>
<b>5BH</b>	127 mm Side-by-Side Bag Holder (GRFHS-21 models)	<b>46</b>
<b>FHS-SH</b>	Scoop Holder – adds 32 mm to width of unit – One standard on GRFHS-PT26, -PTT21 models, not available for GRFHS-21)	<b>46</b>
<b>FHSDIV1</b>	Sectional Divider – 407 W x 83 H mm – GRFHS-16, -26 models	<b>\$27</b>
<b>Chef LED 230V adjustable bulb – GRFHS models only – CE options for input voltages above 200V –</b>		
<b>CLED-2700-230</b>	Chef LED Bulb (emulates incandescent)	<b>\$101</b>
<b>CLED-3000-230</b>	Chef LED Bulb (emulates halogen)	<b>101</b>
<b>CLED-4000-230</b>	Chef LED Bulb (emulates fluorescent)	<b>101</b>

**FOOD PANS AND TRIVETS – PAGE 177**





# Carving Stations

*Supermarkets & Delis  
Restaurants & Cafés • Clubs & Bars*



**DCSB400-1CM** above a **HGSM-1P** *pg. 82*



**DCSB400-R24-1** with optional Bermuda Sand base and optional Bright Brass post and shade *pg. 82*



**DCSB400-R24-1** with optional Gray Granite base and standard Bright Nickel post and shade. Shown with a **GR2S-36** *pg. 82*



**DCSB400-R24-1** with optional Gray Granite base and standard Bright Nickel post and shade *pg. 82*



**GRCSC-24** with accessory left-hand sneeze guard, drip pan and cutting board *pg. 83*



**ACCESSORIES (CSCL-BOARD shown)** *pg. 83*

## Decorative Carving Stations

Decorative Carving Stations provide proper food serving temperatures plus combine the Hatco Decorative Heat Lamp with the simulated stone heated base to create an attractive carving display. Perfect for chef stations in restaurants, hotels, country clubs, casinos and any catered events.

- Available as post mount, permanent counter mount or freestanding with a rounded or rectangular heated simulated stone base (DCS400-1, -1CM do not have bases)
- The patented telescoping heated Decorative Lamp has a 30° shade pivot
- Heated simulated stone bases are made of foodsafe materials
- Heated base is controlled by an adjustable thermostat and power switch
- Units come with matching cutting board (except DCS400-1, -1CM), keeping juices contained and tablecloths clean
- DCS400-1 has a 18 kg weighted base, perfect for buffet use
- Sneeze guard is removable for easy cleaning (DCSB400-R24-1, -2420-1, -3624-2 models only)
- Models with simulated stone are Swanstone®

**DCS400-1CM**  
with optional Bright Brass post and optional Bermuda Sand trim ring



**DCSB400-R24-1**  
with optional Bermuda Sand base and standard Bright Nickel post and shade



**DCSB400-3624-2**  
with standard Night Sky base and standard Bright Nickel posts and shades



### DECORATIVE CARVING STATIONS

Model	No. of Lamps	Width	Heated Base Surface Area (W x D)	Watts	Ship Weight	List Price*
DCS400-1	1	203 mm	—	210-250	15 kg	<b>\$1425</b>
DCS400-1CM	1	156 mm	—	210-250	8 kg	<b>1395</b>
DCSB400-R24-1	1	660 mm	610 mm diameter	530-631	35 kg	<b>3480</b>
DCSB400-2420-1	1	610 mm	610 x 508 mm	667-794	37 kg	<b>3480</b>
DCSB400-3624-2	2	914 mm	914 x 610 mm	1152-1371	58 kg	<b>5060</b>

\* Available with CE Mark, add \$100.

#### All Decorative Carving Station Models Feature:

Models Shipped with: DCS400-1, -1CM One clear coated bulb. DCS400-1 includes black base.  
 DCSB400-R24-1, -2420-1 One clear coated bulb, base heat, glass sneeze guard and cutting board.  
 DCSB400-3624-2 Two clear coated bulbs, base heat, glass sneeze guard and cutting board.  
 Telescoping Clearance: DCS400-1, -1CM (bottom of shade to counter) 406 - 711 mm.  
 DCSB400-R24-1, -2420-1, -3624-2 (bottom of shade to top of cutting board) 356 - 660 mm.

Cord Location: DCS400-1 Base of unit, server side center.  
 DCS400-1CM: Under counter.  
 DCSB400-R24-1, -2420-1, -3624-2 Base of unit, server side on left.

**DCS400-1**  
with optional Bright Brass post and shade and black base



### OPTIONS (available at time of purchase only)

Shade and Post(s) in Plated Finish, no additional charge – Non-Standard colors are non-returnable – Bright Nickel standard –		
BBRASS	Bright Brass	No Charge
BCOPPER	Bright Copper	No Charge
ABRASS	Antique Brass	No Charge
ABRONZE	Antique Bronze	No Charge

Base and Cutting Board (except DCS400-1, -1CM) in simulated stone – Non-Standard colors are non-returnable – Night Sky Standard –		
GGRAN	Gray Granite	No Charge
BSAND	Bermuda Sand	No Charge

Trim Ring (DCS400-1CM only) in simulated stone – Non-Standard colors are non-returnable – Night Sky standard –		
GGRAN	Gray Granite	No Charge
BSAND	Bermuda Sand	No Charge



Close-up of Trim Ring in Standard Night Sky (Unit shown in Optional Plated Antique Bronze finish)

### DCSBxxx-xxxx-xCM

Decorative Carving Station  
 B = Heated Base  
 No Character = No Base Heat  
 Shade Style Number  
 Width of Heated Base (inches)  
 (R = Round Heated Base)  
 No Character = Freestanding  
 CM = Countertop Mount  
 Quantity Overhead Heat Lamps  
 Depth of Heated Base (inches)  
 (Diameter for Round Heated Base)

## Glo-Ray® Carving Stations

An excellent addition to extend food holding times during serving periods is the Glo-Ray Carving Station. Create a complete serving station for buffets by adding it to Hatco's Flav-R-Savor® Holding Cabinet.

- Overhead ceramic heating elements project high intensity radiant heat over entire target area
- Adjustable clearance of 445 to 570 mm
- Portable – includes a 1829 mm cord and plug
- Shatter-resistant incandescent lights illuminate holding area
- Drip pan and cutting board available
- GRCSCLH has base heat



**GRC SCL-24** with accessory left-hand sneeze guard, drip pan and cutting board



**GRC SLH-24** with accessory left-hand sneeze guard, drip pan and cutting board



**GRC SLH-24** controls

### CARVING STATIONS WITH CERAMIC ELEMENTS

Model	No. of Bulbs	Dimensions W x D x H*	Watts		Ship Weight	List Price†
			220V	240V		
<b>GRC SCL-24</b>	4	660 x 711 x 572-724 mm	1040	990	26 kg	<b>\$3253</b>
<b>GRC SLH-24</b>	4	660 x 711 x 572-724 mm	1316	1314	26 kg	<b>3670</b>

\* Width includes accessory left-hand sneeze guard.

† Available with CE Mark, add \$15.

**All Carving Station Models Feature:**

Models Shipped With: Right-hand sneeze guard.

Cord Location: Back side on base.

### ACCESSORIES (available for purchase at any time)

<b>CSCLB/PACC</b>	Left-Hand Sneeze Guard Kit – 1 kg	<b>\$236</b>
<b>CSCL-PAN</b>	Stainless Steel Custom Drip Pan – 508 x 679 x 25 mm – 4 kg	<b>242</b>
<b>CSCL-BOARD</b>	Approved foodsafe Cutting Board – 457 x 610 x 44 mm – 9 kg	<b>229</b>



**CSCLB/PACC**

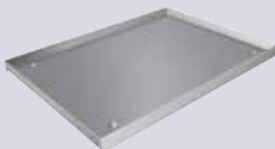

**CSCL-PAN**



**CSCL-BOARD**

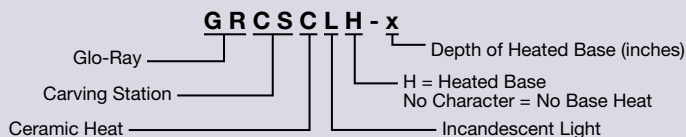



# Portables

*Cafeterias • Buffets • Convenience Stores  
Supermarkets & Delis • Restaurants & Cafés  
Clubs & Bars • Catering • Concessions*



**LW-2** in Standard *Designer* Gray Granite with Accessory food pans *pg. 85*



**GRSR-17** with optional *Designer* Navy Blue color and Accessory food pan *pg. 86*



**GRS-72-1** with Accessory food pans *pg. 87*



**GR2S-30** with optional *Designer* Hunter Green inset panels and Accessory pizza pans *pg. 89*



**GRSSR** with optional 76 or 127 mm risers in Standard Night Sky simulated stone *pg. 90*



**GRSSR20-DL77516** with Standard Night Sky simulated stone heated base *pg. 90*



**GRSS-3618** in optional Bermuda Sand simulated stone *pg. 92*



**HBG-2418** in new optional white glass *pg. 93*



**GRBW-30** with optional enclosures *pg.95*





## Portable Lamp Warmer

The Hatco Portable Lamp Warmer has a specially-designed stand that keeps food holding pans above the countertop and provides insulation to extend holding times.

- Features two vented lamps with heavy-duty sockets
- Adjustable stand from 619 to 772 mm in height
- Cord and plug with in-line power switch

- Gray Granite is Standard color with optional *Designer Colors* available: Warm Red, Black, Gray Granite, White Granite, Navy Blue, Hunter Green, Antique Copper (non-standard colors are non-returnable)
- Holds food pans, wire trivets and fry ribbons



LW-2 with optional *Designer Black Color* and Accessory food pans

### PORTABLE LAMP WARMER

Model	No. of Bulbs	Dimensions W x D x H	Watts		Ship Weight	List Price †
			220-230V	230-240V		
LW-2	2	314 x 548 x 619-772 mm	457-500	500-544	8 kg	\$679

† 220, 240V available with CE Mark, no added charge.

**All Portable Lamp Warmer Models Feature:**

Voltage: 220 or 240, single phase.

Bulbs: Two, 250 watt clear bulbs, **uncoated**.

Cord Location: Back of adjustable stand near top.

Lamp Distance: 267 x 419 mm space from bottom of lamp to top of base.

### OPTIONS (available at time of purchase only)

*Designer Colors – Non-standard colors are non-returnable –*

*Gray Granite Standard –*

<b>RED</b>	Warm Red	<b>No Charge</b>
<b>BLACK</b>	Black	<b>No Charge</b>
<b>WHITE</b>	White Granite	<b>No Charge</b>
<b>NAVY</b>	Navy Blue	<b>No Charge</b>
<b>GREEN</b>	Hunter Green	<b>No Charge</b>
<b>COPPER</b>	Antique Copper	<b>No Charge</b>

### ACCESSORIES (available for purchase at any time)

<b>WHITE-CTD-240</b>	250 Watt Clear Bulb, 240V, Coated (unit accommodates 2 bulbs)	<b>each \$63</b>
----------------------	---	------------------

**FRY RIBBONS – PAGE 80**

**FOOD PANS AND TRIVETS – PAGE 178**

**COLORS AND FINISHES – INSIDE BACK COVER**

Lamp Warmer **LW - x**  
 └─ Quantity of Heat Lamps

Portables

## Glo-Ray® Portable Round Heated Shelves

The contemporary-styled Round Heated Shelf keeps hot food at serving temperatures. Ideal when used for wrapped product or for use behind a sneeze guard with unwrapped food like pizza, biscuits, muffins and cookies.

- Unit is designed for countertop or built-in use – see cutout dimensions below
- Uniform heat distribution with blanket-type element
- Thermostatically-controlled heated base
- Available in three sizes to hold standard 381, 432 or 483 mm diameter pans
- Optional stainless steel trim



**GRSR-17** in optional Navy Blue *Designer* Color with Accessory food pan

**GRSR-19** in optional Hunter Green *Designer* Color with Accessory pizza pan

### GLO-RAY PORTABLE ROUND HEATED SHELVES

Model	Dimensions		Watts		Ship Weight	List Price <sup>‡</sup>
	Dia. x H	Max. Pan Size	220V	240V		
<b>GRSR-15</b>	425 x 98 mm	381 mm Dia.	210	250	5 kg	<b>\$808</b>
<b>GRSR-17</b>	476 x 98 mm	432 mm Dia.	273	325	6 kg	<b>851</b>
<b>GRSR-19</b>	527 x 98 mm	483 mm Dia.	336	400	8 kg	<b>899</b>

<sup>‡</sup> Available with CE Mark, no added charge.

**All Glo-Ray Portable Round Heated Shelf Models Feature:**

**Voltage:** 220 or 240, single phase.

**Cord Location:** Underneath.

### OPTIONS (available at time of purchase only)

**Designer Colors – Non-standard colors are non-returnable – Black Standard –**

<b>RED</b>	Warm Red	<b>No Charge</b>
<b>GRAY</b>	Gray Granite	<b>No Charge</b>
<b>WHITE</b>	White Granite	<b>No Charge</b>
<b>NAVY</b>	Navy Blue	<b>No Charge</b>
<b>GREEN</b>	Hunter Green	<b>No Charge</b>
<b>COPPER</b>	Antique Copper	<b>No Charge</b>
<b>SS SIDE</b>	Stainless Steel Side	<b>No Charge</b>

**FOOD PANS AND TRIVETS – PAGE 178**

**COLORS AND FINISHES – INSIDE BACK COVER**

### PORTABLE ROUND HEATED SHELVES COUNTERTOP CUTOUT DIMENSIONS (For Built-In Applications)

Model	Minimum Diameter	Maximum Diameter	Below Counter
<b>GRSR-15</b>	410 mm	413 mm	137 mm
<b>GRSR-17</b>	460 mm	464 mm	137 mm
<b>GRSR-19</b>	511 mm	514 mm	137 mm

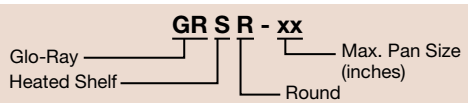



## Glo-Ray® Portable Heated Shelves

Whether you need a heated workspace or extra base heat in a pass-through or buffet area, Hatco's full line of Glo-Ray Heated Shelf options can help you. Using a blanket heating element for an even temperature, the thermostatically-controlled base safely extends the holding time of your food.

Flexibility, style and quality mark these workhorses of the buffet. Available in a variety of widths and depths to meet your specific needs.

- Uniform heat distribution with a blanket-type element
- Built-in adjustable thermostat controls surface temperature
- Extruded aluminum base with stainless steel top – optional hardcoated aluminum surface
- Accessory 102 mm legs – Standard on 914 mm and wider models
- Accessory slant leg kit and pan rail available
- Model widths from 457 to 1829 mm
- Model depths: 152, 197, 248, 305, 349, 394, 400, 445, 495, 546, 597, 648 mm
- Optional *Designer Colors*: Warm Red, Black, Gray Granite, White Granite, Navy Blue, Hunter Green, Antique Copper. Non-standard colors are non-returnable

*continued on next page...*



GRS-60-I

### GLO-RAY PORTABLE HEATED SHELVES

Model	Dimensions W x H	Watts		Ship Weight	List Price*
		220V	240V		
<b>495 mm depth I – Standard 495 mm Depth accommodates 305 x 508 mm steam table pans</b>					
GRS-18-I	457 x 59 mm	229	272	7 kg	\$ 800
GRS-24-I	610 x 59 mm	320	381	9 kg	865
GRS-30-I	762 x 59 mm	412	490	11 kg	935
GRS-36-I	914 x 137 mm	503	599	13 kg	995
GRS-42-I	1067 x 137 mm	549	653	15 kg	1106
GRS-48-I	1219 x 137 mm	640	762	16 kg	1168
GRS-54-I	1372 x 137 mm	732	871	19 kg	1238
GRS-60-I	1524 x 137 mm	823	980	20 kg	1300
GRS-66-I	1676 x 137 mm	915	1089	23 kg	1363
GRS-72-I	1829 x 137 mm	1006	1198	25 kg	1427

#### 197 mm depth B

GRS-18-B	457 x 59 mm	91	109	5 kg	\$612
GRS-24-B	610 x 59 mm	114	136	5 kg	645
GRS-30-B	762 x 59 mm	137	163	5 kg	678
GRS-36-B	914 x 137 mm	160	191	6 kg	708
GRS-42-B	1067 x 137 mm	205	245	9 kg	777
GRS-48-B	1219 x 137 mm	228	272	9 kg	800
GRS-54-B	1372 x 137 mm	251	299	9 kg	826
GRS-60-B	1524 x 137 mm	274	327	10 kg	854
GRS-66-B	1676 x 137 mm	297	354	12 kg	879
GRS-72-B	1829 x 137 mm	320	381	11 kg	919

#### 305 mm depth D

GRS-18-D	457 x 59 mm	183	218	5 kg	\$ 667
GRS-24-D	610 x 59 mm	229	272	7 kg	714
GRS-30-D	762 x 59 mm	274	327	8 kg	757
GRS-36-D	914 x 137 mm	320	381	9 kg	792
GRS-42-D	1067 x 137 mm	412	490	10 kg	879
GRS-48-D	1219 x 137 mm	457	544	12 kg	925
GRS-54-D	1372 x 137 mm	503	599	14 kg	963
GRS-60-D	1524 x 137 mm	548	653	15 kg	1003
GRS-66-D	1676 x 137 mm	594	708	16 kg	1045
GRS-72-D	1829 x 137 mm	640	762	17 kg	1084

\* Available with CE Mark, no added charge.

#### All Glo-Ray Portable Heated Shelf Models Feature:

Voltage: 220 or 240, single phase.

Cord Location: Center of side with controls.

Pan Capacity 305 x 508 mm): GRS-18-I, -24-I = 1-pan

GRS-30-I, -36-I = 2-pan

GRS-42-I, -48-I = 3-pan

GRS-54-I, -60-I = 4-pan

GRS-66-I, -72-I = 5-pan

### GLO-RAY PORTABLE HEATED SHELVES – continued next page

Model	Dimensions W x H	Watts		Ship Weight	List Price*
		220V	240V		
<b>152 mm depth A</b>					
GRS-18-A	457 x 59 mm	91	109	5 kg	\$601
GRS-24-A	610 x 59 mm	114	136	5 kg	620
GRS-30-A	762 x 59 mm	137	163	4 kg	645
GRS-36-A	914 x 137 mm	160	191	5 kg	667
GRS-42-A	1067 x 137 mm	205	245	7 kg	736
GRS-48-A	1219 x 137 mm	228	272	7 kg	757
GRS-54-A	1372 x 137 mm	251	299	8 kg	777
GRS-60-A	1524 x 137 mm	274	327	8 kg	792
GRS-66-A	1676 x 137 mm	297	354	9 kg	814
GRS-72-A	1829 x 137 mm	320	381	10 kg	832

#### 248 mm depth C

GRS-18-C	457 x 59 mm	114	136	4 kg	\$645
GRS-24-C	610 x 59 mm	160	191	6 kg	678
GRS-30-C	762 x 59 mm	206	245	6 kg	714
GRS-36-C	914 x 137 mm	252	299	7 kg	748
GRS-42-C	1067 x 137 mm	274	327	8 kg	826
GRS-48-C	1219 x 137 mm	320	381	9 kg	854
GRS-54-C	1372 x 137 mm	366	436	10 kg	885
GRS-60-C	1524 x 137 mm	412	490	11 kg	935
GRS-66-C	1676 x 137 mm	458	544	13 kg	963
GRS-72-C	1829 x 137 mm	504	599	13 kg	995

#### 349 mm depth E

GRS-18-E	457 x 59 mm	183	218	6 kg	\$ 692
GRS-24-E	610 x 59 mm	229	272	6 kg	736
GRS-30-E	762 x 59 mm	274	327	8 kg	786
GRS-36-E	914 x 137 mm	320	381	10 kg	832
GRS-42-E	1067 x 137 mm	412	490	12 kg	925
GRS-48-E	1219 x 137 mm	457	544	13 kg	973
GRS-54-E	1372 x 137 mm	502	599	14 kg	1022
GRS-60-E	1524 x 137 mm	548	653	16 kg	1066
GRS-66-E	1676 x 137 mm	594	708	17 kg	1106
GRS-72-E	1829 x 137 mm	640	762	18 kg	1161

\* Available with CE Mark, no added charge.

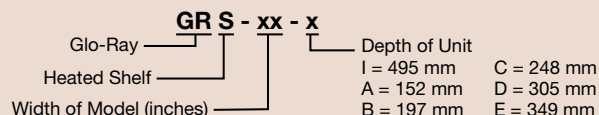

## Glo-Ray® Portable Heated Shelves

continued



GRS-30-I in optional *Designer Color* with Accessory food pans, shown below a **GRAH-36** Strip Heater in optional *Designer Color*, infinite switch and Accessory C-leg stand

### GLO-RAY PORTABLE HEATED SHELVES continued...

Model	Dimensions W x H	Watts		Ship Weight	List Price <sup>‡</sup>
		220V	240V		
<b>394 mm depth F</b>					
GRS-18-F	457 x 59 mm	183	218	6 kg	\$ 708
GRS-24-F	610 x 59 mm	229	272	8 kg	757
GRS-30-F	762 x 59 mm	274	327	10 kg	809
GRS-36-F	914 x 137 mm	320	381	11 kg	854
GRS-42-F	1067 x 137 mm	412	490	12 kg	963
GRS-48-F	1219 x 137 mm	457	544	15 kg	1012
GRS-54-F	1372 x 137 mm	503	599	17 kg	1066
GRS-60-F	1524 x 137 mm	548	653	18 kg	1121
GRS-66-F	1676 x 137 mm	594	708	19 kg	1168
GRS-72-F	1829 x 137 mm	640	762	21 kg	1221
<b>445 mm depth H</b>					
GRS-18-H	457 x 59 mm	206	245	7 kg	\$ 748
GRS-24-H	610 x 59 mm	274	327	8 kg	800
GRS-30-H	762 x 59 mm	343	408	10 kg	854
GRS-36-H	914 x 137 mm	412	490	12 kg	925
GRS-42-H	1067 x 137 mm	480	572	15 kg	1035
GRS-48-H	1219 x 137 mm	549	653	16 kg	1091
GRS-54-H	1372 x 137 mm	618	735	18 kg	1150
GRS-60-H	1524 x 137 mm	686	817	20 kg	1221
GRS-66-H	1676 x 137 mm	755	898	22 kg	1278
GRS-72-H	1829 x 137 mm	823	980	23 kg	1330
<b>597 mm depth K</b>					
GRS-18-K	457 x 59 mm	297	354	10 kg	\$ 879
GRS-24-K	610 x 59 mm	389	463	12 kg	956
GRS-30-K	762 x 59 mm	480	572	15 kg	1028
GRS-36-K	914 x 137 mm	572	681	16 kg	1106
GRS-42-K	1067 x 137 mm	686	817	20 kg	1238
GRS-48-K	1219 x 137 mm	778	925	22 kg	1318
GRS-54-K	1372 x 137 mm	869	1034	24 kg	1393
GRS-60-K	1524 x 137 mm	961	1143	25 kg	1478
GRS-66-K	1676 x 137 mm	1052	1252	31 kg	1557
GRS-72-K	1829 x 137 mm	1144	1361	31 kg	1630

<sup>‡</sup> Available with CE Mark, no added charge.

### GLO-RAY PORTABLE HEATED SHELVES

Model	Dimensions W x H	Watts		Ship Weight	List Price <sup>‡</sup>
		220V	240V		
<b>400 depth G</b>					
GRS-18-G	457 x 59 mm	206	245	8 kg	\$ 714
GRS-24-G	610 x 59 mm	274	327	8 kg	763
GRS-30-G	762 x 59 mm	343	408	10 kg	814
GRS-36-G	914 x 137 mm	412	490	12 kg	865
GRS-42-G	1067 x 137 mm	480	572	13 kg	982
GRS-48-G	1219 x 137 mm	549	653	15 kg	1028
GRS-54-G	1372 x 137 mm	618	735	38 kg	1084
GRS-60-G	1524 x 137 mm	686	817	19 kg	1138
GRS-66-G	1676 x 137 mm	755	898	21 kg	1195
GRS-72-G	1829 x 137 mm	823	980	21 kg	1238
<b>546 mm depth J</b>					
GRS-18-J	457 x 59 mm	274	327	9 kg	\$ 832
GRS-24-J	610 x 59 mm	343	408	11 kg	911
GRS-30-J	762 x 59 mm	412	490	14 kg	982
GRS-36-J	914 x 137 mm	480	572	15 kg	1050
GRS-42-J	1067 x 137 mm	618	735	18 kg	1168
GRS-48-J	1219 x 137 mm	686	817	20 kg	1245
GRS-54-J	1372 x 137 mm	755	898	22 kg	1318
GRS-60-J	1524 x 137 mm	823	980	24 kg	1387
GRS-66-J	1676 x 137 mm	892	1062	27 kg	1465
GRS-72-J	1829 x 137 mm	961	1143	29 kg	1537
<b>648 depth L</b>					
GRS-18-L	457 x 59 mm	320	381	10 kg	\$ 911
GRS-24-L	610 x 59 mm	435	517	12 kg	995
GRS-30-L	762 x 59 mm	549	653	15 kg	1073
GRS-36-L	914 x 137 mm	663	789	17 kg	1161
GRS-42-L	1067 x 137 mm	755	898	20 kg	1300
GRS-48-L	1219 x 137 mm	869	1034	23 kg	1387
GRS-54-L	1372 x 137 mm	984	1171	26 kg	1473
GRS-60-L	1524 x 137 mm	1098	1307	27 kg	1557
GRS-66-L	1676 x 137 mm	1212	1443	29 kg	1645
GRS-72-L	1829 x 137 mm	1327	1579	31 kg	1731

<sup>‡</sup> Available with CE Mark, no added charge.

**All Glo-Ray Portable Heated Shelf Models Feature:**

Voltage: 220 or 240, single phase.

Cord Location: Center of side with controls.

**OPTIONS AND ACCESSORIES – PAGE 89**





## Glo-Ray® Designer Portable Heated Shelves

Using a blanket heating element for an even temperature, the thermostatically-controlled base safely extends the holding time of your food. Hatco's Designer Portable Heated Shelves can blend into any décor.

- Built-in adjustable thermostatic controls
- Model widths from 768 x 1988 mm
- Rounded edges and hardcoated aluminum surfaces offer a modern style for front-of-the-house applications
- Optional Dark Gray corner caps (Black Standard) and Designer Color inset panels available
- 102 mm legs Standard on 921 mm and wider models

GR2S-30 with optional Designer Color inset panels and Accessory pizza pans



### GLO-RAY DESIGNER PORTABLE HEATED SHELVES

Model*	Dimensions W x D x H	Pan Capacity 324 x 527 mm pan	Voltage Single Phase	Watts	Ship Weight	List Price*
GR2S-24	768 x 686 x 101 mm	1	220, 240	350	17 kg	<b>\$1803</b>
GR2S-30	921 x 686 x 178 mm	2	220, 240	450	18 kg	<b>1935</b>
GR2S-36	1073 x 686 x 178 mm	2	220, 240	550	20 kg	<b>2070</b>
GR2S-42	1226 x 686 x 178 mm	3	220, 240	600	23 kg	<b>2283</b>
GR2S-48	1378 x 686 x 178 mm	3	220, 240	700	25 kg	<b>2419</b>
GR2S-54	1530 x 686 x 178 mm	4	220, 240	800	28 kg	<b>2549</b>
GR2S-60	1683 x 686 x 178 mm	4	220, 240	900	30 kg	<b>2685</b>
GR2S-66	1835 x 686 x 178 mm	5	220, 240	1000	34 kg	<b>2817</b>
GR2S-72	1988 x 686 x 178 mm	5	220, 240	1100	37 kg	<b>2952</b>

\* When no color is specified, color inset panels and corner caps will be black.

\* CE Mark not available.

All Glo-Ray Designer Portable Heated Shelf Models Feature:

Usable Heated Shelf Space: (Width of unit minus 162) x 552 D mm.

Cord Location: Center of bottom on control side.

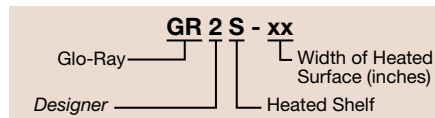

### OPTIONS (available at time of purchase only)

Designer Colors (top surface not painted) –

Non-standard colors are non-returnable – Clear Anodized Standard –

RED	Warm Red	\$147
BLACK	Black	\$147
GRAY	Gray Granite	\$147
WHITE	White Granite	\$147
NAVY	Navy Blue	\$147
GREEN	Hunter Green	\$147
COPPER	Antique Copper	\$147

Designer Inset Panel colors (GR2S models) –

Non-standard colors are non-returnable – Black Standard –

RED	Warm Red	No Charge
GRAY	Gray Granite	No Charge
WHITE	White Granite	No Charge
NAVY	Navy Blue	No Charge
GREEN	Hunter Green	No Charge
COPPER	Antique Copper	No Charge

Designer Corner Caps, GR2S models –

Non-standard colors are non-returnable – Black Standard –

DKGRAY	Dark Gray Corner Caps	No Charge
--------	-----------------------	-----------

Hardcoated surface in lieu of stainless steel on Standard 495 mm deep

GRS models only (please consult factory for pricing of other depths)

HC 18-42	GRS-18 through GRS-42	\$176
HC 48-72	GRS-48 through GRS-72	297
GRS-RECTH	Thermostat Guard (GRS models only)	No Charge



### ACCESSORIES (available for purchase at any time)

GRS-LEGS	102 mm Adjustable Legs (GRS models only, Standard on units GRS-36 and larger)	\$47
2SD-LEGS	102 mm adjustable Legs for GR2S-24 (Standard on GR2S-30 and larger)	89
GRS-SLANT	Slant Leg Kit for models 305 mm deep or deeper (GRS models only)	24
<b>Pan Rail for 495 mm deep GRS models only –</b>		
2 RAIL	2-pan	\$155
3 RAIL	3-pan	166
4 RAIL	4-pan	311
5 RAIL	5-pan	321

FOOD PANS AND TRIVETS – PAGE 178

COLORS AND FINISHES – INSIDE BACK COVER

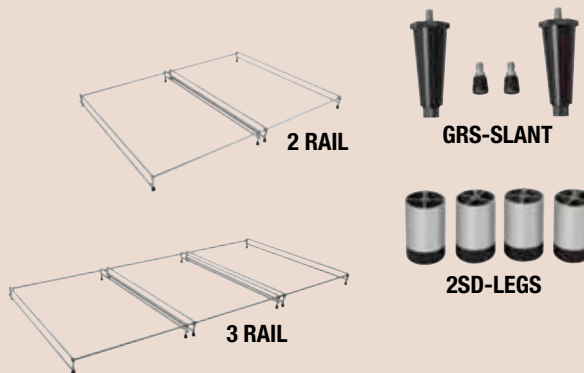

## Glo-Ray® Portable Round Heated Simulated Stone Shelves

Hatco's Glo-Ray Portable Round Heated Simulated Stone Shelves are made of foodsafe materials and come in three simulated stone colors. These unique warmers will safely hold food hot while blending in with your décor and are ideal for buffet lines or as hors d'oeuvres displays.

- Blanket-type element creates uniform heat across the entire simulated stone surface
- Features a lighted rocker switch and thermostatically-controlled heated base to help hold your food hot and delicious
- Optional 76 mm or 127 mm risers available in stainless steel (Standard) or Designer Colors
- Models with simulated stone are Swanstone®

**GRSSR-16** in Standard Night Sky simulated stone with optional 76 mm Riser in Designer Color



**GRSSR-18** in Standard Night Sky simulated stone with optional 127 mm Riser in Designer Color



**GRSSR-20** in Standard Night Sky simulated stone



**GRSSR20-DL77516** in Standard Night Sky simulated stone with Standard Black base and lamp



### GLO-RAY PORTABLE ROUND HEATED SIMULATED STONE SHELVES

Model	Dimensions Dia. x H	Watts		Ship Weight	List Price <sup>‡</sup>
		220V-230V	230V-240V		
<b>GRSSR-16</b>	406 x 66 mm	190-220	220-250	6 kg	<b>\$ 1015</b>
<b>GRSSR-18</b>	457 x 66 mm	265-295	295-325	7 kg	<b>1083</b>
<b>GRSSR-20</b>	508 x 66 mm	330-370	370-400	8 kg	<b>1151</b>

### GLO-RAY PORTABLE ROUND HEATED SIMULATED STONE SHELVES with DECORATIVE LAMP

Model	Dimensions W x D x H	Watts		Ship Weight	List Price <sup>‡</sup>
		220V-230V	230V-240V		
<b>GRSSR20-DL77516</b>	508 x 572 x 914 mm	550-600	600-650	15 kg	<b>\$1749</b>

<sup>‡</sup> Available with CE Mark, add \$20.

All Glo-Ray Round Heated Simulated Stone Shelf Models With Decorative Lamp Feature:

**Voltage:** 220 or 240, single phase.

**Bulb:** One, 250 watt clear bulb, uncoated.

**Temperature Range:** 38°-93°C.

**Cord Location:** Back side on base.

**Lamp Distance:** 415 mm space from bottom of shade to base.

### OPTIONS AND ACCESSORIES – PAGE 91

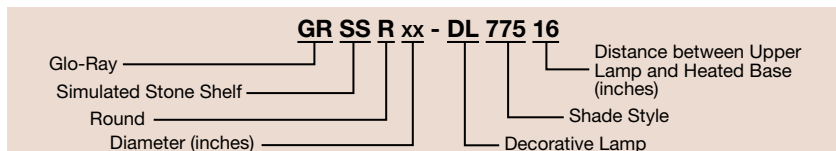



Two **GRSSR20-DL77516** units in optional Gray Granite simulated stone and Standard *Designer* Black Base and Shade

**OPTIONS** (available at time of purchase only)

**Designer Color Base (and Lamp for GRSSRxx-DL77516 models) – Non-standard colors are non-returnable – Black Standard –**

<b>RED</b>	Warm Red	
<b>GRAY</b>	Gray Granite	No Charge
<b>NAVY</b>	Navy Blue	No Charge
<b>COPPER</b>	Antique Copper	No Charge
<b>WHITE</b>	White Granite	No Charge
<b>GREEN</b>	Hunter Green	No Charge

**Simulated stone color – Non-standard colors are non-returnable – Night Sky Standard –**

<b>SS-GGRAN</b>	Gray Granite	No Charge
<b>SS-BSAND</b>	Bermuda Sand	No Charge

**76 mm Risers (GRSSR models only), available in Designer Colors – Non-standard colors are non-returnable – Stainless steel Standard –**

<b>3RISER16</b>	GRSSR-16	\$51
<b>3RISER18</b>	GRSSR-18	51
<b>3RISER20</b>	GRSSR-20	51

**127 mm Risers (GRSSR models only), available in Designer Colors – Non-standard colors are non-returnable – Stainless steel Standard –**

<b>5RISER16</b>	GRSSR-16	\$67
<b>5RISER18</b>	GRSSR-18	67
<b>5RISER20</b>	GRSSR-20	67

**ACCESSORIES** (available for purchase at any time)

<b>WHITE-CTD-240</b>	250 Watt Clear Bulb, 240V, Coated (GRSSR20-DL77516 model accommodates one bulb)	each \$63
----------------------	---	-----------

**COLORS AND FINISHES – INSIDE BACK COVER**

Portables



### Glo-Ray® Portable Rectangular Heated Simulated Stone Shelves

Match the heat zone to your countertops with Hatco's Glo-Ray Portable Rectangular Heated Simulated Stone Shelves. These portable foodsafe shelves come in three simulated stone colors and are ideal for buffet lines or as hors d'oeuvre displays. The unique warmers will safely hold food hot while blending in with your décor.

- Shelves are made of foodsafe materials
- Features a lighted rocker switch and thermostatically-controlled heated base to help hold your food hot and delicious
- Models with simulated stone are Swanstone®



GRSS-3618 in optional Bermuda Sand simulated stone (view of base)



GRSS-3618 in Standard Night Sky simulated stone

#### GLO-RAY PORTABLE RECTANGULAR HEATED SIMULATED STONE SHELVES

Model	Dimensions W x D x H	Watts		Ship Weight	List Price*
		220V-230V	230V-240V		
GRSS-2418	610 x 457 x 64 mm	534-583	583-635	12 kg	\$1518
GRSS-3018	762 x 457 x 64 mm	655-716	716-780	14 kg	1589
GRSS-3618	914 x 457 x 64 mm	782-854	854-930	16 kg	1657
GRSS-4818*	1219 x 457 x 159 mm	1068-1166	1166-1270	20 kg	1792
GRSS-6018*	1524 x 457 x 159 mm	1310-1432	1432-1560	25 kg	2334
GRSS-7218*	1829 x 457 x 159 mm	1564-1708	1708-1860	31 kg	2467

\* Available with CE Mark, add \$20.

\* Height includes Standard 102 mm legs.

All Glo-Ray Portable Rectangular Heated Simulated Stone Shelf Models Feature:

Voltage: 220 or 240, single phase.

Cord Location: Center of side with switch.

#### OPTIONS (available at time of purchase only)

Simulated stone colors – Non-standard colors are non-returnable – Night Sky Standard –

SS-GGRAN	Gray Granite	No Charge
SS-BSAND	Bermuda Sand	No Charge

#### COLORS AND FINISHES – INSIDE BACK COVER

Portables

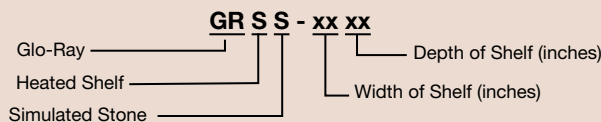





## Glo-Ray® Mini-Merchandisers

Hatco's convenient Mini-Merchandisers create impulse sales by placing fresh product in front of customers. Using a limited amount of valuable counterspace, these flexible warmers come in a variety of shapes, sizes and colors to hold food samples, hors d'oeuvres and packaged product at just the right temperature.

- Ideal for delis, supermarkets, convenience stores, kiosks or concession stands where counterspace is limited
- Sturdy sneeze guard safeguards food serving areas
- Lighted rocker switch for easy On/Off
- Shatter-resistant incandescent lights enhance product displays while safeguarding food from bulb breakage
- Thermostatically-controlled heated base to extend holding times of most foods
- Pre-focused infrared top heat directs heat to the outer edges where heat loss is greatest
- Food stop, 102 mm food bins Standard (GRHW-1SG only)

GRHW-1P with  
Accessory food pan



GRHW-2P with 102 mm legs  
and Accessory food pans



### GLO-RAY MINI-MERCHANDISERS

Model	No. of Bulbs	Dimensions (W x D x H) Includes sneeze guard	Base Dimensions W x D	Watts		Ship Weight	List Price*
				220V	240V		
GRHW-1P	2	565 x 414 x 451 mm	533 x 349 mm	782	838	16 kg	\$1582
GRHW-2P	4	1098 x 414 x 527 mm	1099 x 349 mm	1560	1680	30 kg	2087
GRHW-1SG	2	565 x 414 x 451 mm	533 x 349 mm	782	838	17 kg	1886

\* Available with CE Mark, add \$15.

#### All Glo-Ray Mini-Merchandiser Models Feature:

Voltage: 220 or 240, single phase.

Mini-Merchandiser Shipped with: Thermostatically-controlled base, 191 mm sneeze guard, display lights, 25 mm rubber legs (except GRHW-2P has 102 mm legs), five 102 mm bins (GRHW-1SG only), 1829 mm cord and plug.

Cord Location: Base end plate, same side as switch.

### OPTIONS (available at time of purchase only)

Designer Colors – Non-standard colors are non-returnable – Clear Anodized Aluminum Standard –		
RED	Warm Red	\$360
BLACK	Black	360
GRAY	Gray Granite	360
WHITE	White Granite	360
NAVY	Navy Blue	360
GREEN	Hunter Green	360
COPPER	Antique Copper	360
PANEL	Plexi-glass Side Panels	171

### ACCESSORIES (available for purchase at any time)

4"LEGS	102 mm Adjustable Legs (GRHW-1P, -1SG only) – Standard on GRHW-2P	\$47
--------	---	------

### FOOD PANS AND TRIVETS – PAGE 178

### COLORS AND FINISHES – INSIDE BACK COVER

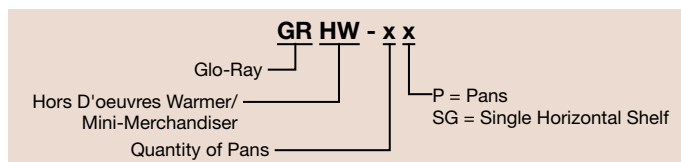



## Glo-Ray® Buffet Warmers

Hold hot food at optimum serving temperatures on buffet lines or at temporary serving areas with Hatco Glo-Ray Buffet Warmers. Choose from either Standard or *Designer* style models in many widths to fit your operation.

- Available with *Designer* Color insets with the choice of an entire unit in color as well
- Thermostatically-controlled heated base of 27°- 93°C extends holding times of most foods
- Pre-focused infrared top heat directs heat to the outer edges where heat loss is greatest
- Sturdy plexi-glass sneeze guard
- Shatter-resistant incandescent lights enhance product displays while safeguarding food from bulb breakage
- Available in a variety of widths from 635-1988 mm



GRBW-30 with optional *Designer* Color and Accessory food pans



GR2BW-30 with optional *Designer* Warm Red inset panels and Accessory food pans



GR2BW-30 with optional *Designer* Color and plexi-glass side enclosures and Accessory food pans

### GLO-RAY BUFFET WARMERS

Model	No. of Light Bulbs	Dimensions (W x D x H) Includes sneeze guard	Max. Pan Capacity 324 x 527 mm pan	Watts		Ship Weight	List Price*
				220V	240V		
GRBW-24	2	635 x 572 x 451 mm	1	920	1000	21 kg	\$1715
GRBW-30	2	787 x 572 x 451 mm	2	1172	1270	24 kg	1893
GRBW-36	3	940 x 572 x 527 mm	2	1454	1578	26 kg	2071
GRBW-42	3	1092 x 572 x 527 mm	3	1648	1782	31 kg	2249
GRBW-48	4	1245 x 572 x 527 mm	3	1940	2040	34 kg	2427
GRBW-54	4	1397 x 572 x 527 mm	4	2182	2360	37 kg	2605
GRBW-60	5	1549 x 572 x 527 mm	4	2474	2680	41 kg	2783
GRBW-66	5	1702 x 572 x 527 mm	5	2726	2948	44 kg	2961
GRBW-72	5	1854 x 572 x 527 mm	5	2983	3113	49 kg	3139

\* Available with CE Mark, add \$20.

#### All Glo-Ray Buffet Warmer Models Feature:

Voltage: 220 or 240, single phase.

GRBW Base Dimensions: 635-1854 W x 495 D mm.

Cord Location: Base end plate, same side as switch.

### GLO-RAY DESIGNER BUFFET WARMERS

Model*	No. of Light Bulbs	Dimensions (W x D x H) Includes sneeze guard	Max. Pan Capacity 324 x 527 mm pan	Watts		Ship Weight	List Price*
				220V	240V		
GR2BW-24	2	768 x 686 x 483 mm	1	950	970	35 kg	\$3032
GR2BW-30	2	921 x 686 x 559 mm	2	1210	1230	39 kg	3315
GR2BW-36	2	1073 x 686 x 559 mm	2	1450	1470	44 kg	3598
GR2BW-42	4	1226 x 686 x 559 mm	3	1750	1790	50 kg	3971
GR2BW-48	4	1378 x 686 x 559 mm	3	2000	2040	57 kg	4344
GR2BW-54	4	1530 x 686 x 559 mm	4	2250	2290	59 kg	4792
GR2BW-60	6	1683 x 686 x 559 mm	4	2600	2660	70 kg	5240
GR2BW-66	6	1835 x 686 x 559 mm	5	2860	2920	77 kg	5608
GR2BW-72	6	1988 x 686 x 559 mm	5	3125	3185	84 kg	5976

\* When no color is specified, color inset panels and corner caps will be black.

\* Available with CE Mark, add \$20.

■ Cord with out plug on 240V

#### All Glo-Ray Designer Buffet Warmer Models Feature:

Voltage: 220 or 240, single phase.

Usable Heated Shelf Space: Width of unit minus 165 W x 552 D mm.

Cord Location: Center of bottom on control side.

### OPTIONS AND ACCESSORIES – PAGE 96

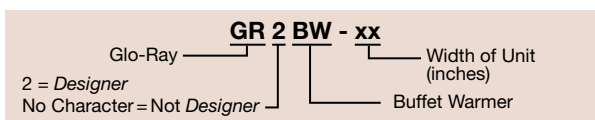

Portables



GRBW-30 with  
Accessory food pans

**OPTIONS** (available at time of purchase only)

**Designer Colors – Non-standard colors are non-returnable – Clear Anodized Aluminum Standard –**

<b>RED</b>	Warm Red	<b>\$360</b>
<b>BLACK</b>	Black	<b>360</b>
<b>NAVY</b>	Navy Blue	<b>360</b>
<b>GRAY</b>	Gray Granite	<b>360</b>
<b>WHITE</b>	White Granite	<b>360</b>
<b>GREEN</b>	Hunter Green	<b>360</b>
<b>NAVY</b>	Navy Blue	<b>360</b>
<b>COPPER</b>	Antique Copper	<b>360</b>

**Designer Inset Panel colors, GR2BW models – Non-standard colors are non-returnable – Black Standard –**

<b>RED</b>	Warm Red	<b>No Charge</b>
<b>NAVY</b>	Navy Blue	<b>No Charge</b>
<b>GRAY</b>	Gray Granite	<b>No Charge</b>
<b>WHITE</b>	White Granite	<b>No Charge</b>
<b>GREEN</b>	Hunter Green	<b>No Charge</b>
<b>NAVY</b>	Navy Blue	<b>No Charge</b>
<b>COPPER</b>	Antique Copper	<b>No Charge</b>

**Designer Corner Caps, GR2BW models – Non-standard colors are non-returnable – Black Standard –**

<b>DKGRAY</b>	Dark Gray	<b>No Charge</b>
---------------	-----------	------------------

**Acrylic Front and two Side Enclosures in lieu of Sneeze Guards – (GRBW-24, -30, -36, -42, -48 models only)**

<b>FRTENCL-24, -30</b>	-24, -30 models	<b>\$328</b>
<b>FRTENCL-36, -42, -48</b>	-36, -42, -48 models	<b>375</b>
<b>SIDE-ENCL</b>	Two Acrylic Side Enclosures (GRBW models only)	<b>\$223</b>
<b>SIDE-ENCL2</b>	Two Acrylic Side Enclosures (GR2BW models only)	<b>223</b>

**Hardcoated Surface, GRBW models –**

<b>HC 24-42</b>	GRBW-24 through GRBW-42	<b>\$117</b>
<b>HC 48-72</b>	GRBW-48 through GRBW-72	<b>234</b>
<b>INF</b>	Infinite Control for top heat only (GRBW-24 through -60 and GR2BW-24 through -60 models only)	<b>\$37</b>
<b>9.375BP</b>	238 mm Sneeze Guard in lieu of Standard 191 mm (GRBW models only)	<b>add per 305 mm per side 8</b>
<b>14BP</b>	356 mm Sneeze Guard in lieu of Standard 191 mm	<b>add per 305 mm per side 19</b>

**ACCESSORIES**

<b>GRBW-LEGS</b>	102 mm Adjustable Legs for GRBW-24 models (Standard on GRBW-36 or larger)	<b>\$47</b>
<b>2SD-LEGS</b>	102 mm Designer Legs for GR2BW-24 models (Standard on GR2BW-30 or larger)	<b>89</b>
<b>Pan Rail for GRBW models (not for use with Acrylic Front Enclosure)</b>		
<b>2 RAIL</b>	2-pan	<b>\$155</b>
<b>3 RAIL</b>	3-pan	<b>166</b>
<b>4 RAIL</b>	4-pan	<b>311</b>
<b>5 RAIL</b>	5-pan	<b>321</b>
<b>Chef LED 230V adjustable bulb – CE options for input voltages above 200V – See page 45 for more information –</b>		
<b>CLED-2700-230</b>	Warm light	<b>101</b>
<b>CLED-3000-230</b>	Warm light	
<b>CLED-4000-230</b>	Cool light	

**COLORS AND FINISHES – INSIDE BACK COVER**



**Chef LED Bulb**

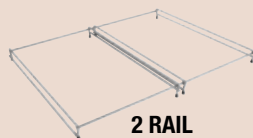

**2 RAIL**

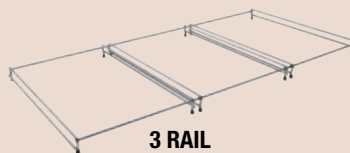

**3 RAIL**



**2SD-LEGS**



# Built-Ins

*Cafeterias • Buffets*

*Supermarkets & Delis • Restaurants & Cafés*

**New Models Available**



**CSSBF-48-S** in optional Bermuda Sand simulated stone built into a Bermuda Sand simulated stone countertop *pg. 99*



**HCSBF-48-S** in hot mode *pg. 108*



**HCSBF-48-S** in cold mode *pg. 108*



**GRSSB-3618** in Bermuda Sand simulated stone built into a simulated stone countertop, shown below a **GR2AHL-42** Strip Heater with optional sneeze guards and adjustable tubular stands *pg. 110*



**GRSSB-3618** in Standard Night Sky simulated stone built into a granite countertop *pg. 110*



**HBGBH-2418** and a **HBGB-3618** with optional Trim Ring in new optional White Glass *pg. 111*



**GRSB-30-I** and accessory food pans shown below a **GRAHL-36** Strip Heater with optional sneeze guards and adjustable tubular stands *pg. 113*



**GRSB-54-I** and accessory food pans shown below a **GRAL-96D** Strip Heater with optional sneeze guard *pg. 113*



**GRSBF-60-0** built into a simulated stone countertop with accessory food pans, shown below a **GR2AL-96D** Strip Heater in *Designer Black* with optional Sneeze Guards *pg. 114*

## Cold Simulated Stone Shelves Built-In

Hatco's Cold Simulated Stone Shelves Built-In are a must for buffet lines in cafeterias, restaurants and much more! CSSBR and CSSBX have the benefit of allowing fabricators freedom to design.

- Patented thermal break reduces condensation and temperature transfer on adjacent surfaces
- All models are bottom mount units
- Simulated stone is Swanstone®
- All models match the GRSSB Heated Simulated Stone Built-In Shelves for a fully integrated look
- Control Box comes Standard with 1219 mm lead wire
- CSSB Control Box can be mounted 1219 mm from center of shelf

- Condensing unit may be mounted up to 1219 mm away from center of shelf (CSSB models only)
- CSSB models offer a long, flexible refrigerant line which allows condensing unit to be pulled out for service
- Condensing unit features easy serviceability with sight glass, service valves, dryer/filter and receiver (CSSB, CSSBR models only)
- CSSBR models have unattached Condensing unit and Control Box, CSSBX models have unattached Control Box only



**CSSB-4818**  
in optional Bermuda Sand simulated stone



**CSSBR-4818**  
in Standard Night Sky simulated stone – All models come with unattached Condenser and Control Box



**CSSBX-4818**  
in Granite Gray simulated stone – All models come with unattached Control Box only

### COLD SIMULATED STONE SHELVES BUILT-IN (flush to countertop)

Model*	Overall Shelf Dim. (includes brackets)	Usable Space	List Price
	W x D	W x D	
<b>CSSB-2418</b>	686 x 533 mm	610 x 457 mm	<b>\$6062</b>
<b>CSSB-3018</b>	383 x 533 mm	762 x 457 mm	<b>6117</b>
<b>CSSB-3618</b>	991 x 533 mm	914 x 457 mm	<b>6300</b>
<b>CSSB-4818</b>	1295 x 533 mm	1219 x 457 mm	<b>7114</b>

\* Not available with CE Mark.

Consult factory for refrigerant specifications.

**All Cold Simulated Stone Shelf Built-In Models Feature:**

**Voltage:** 220, 230 or 240 (CE not available). **Models Shipped with:** Electronic Temperature Control and condensing unit, 1829 mm cord and plug

### COLD SIMULATED STONE SHELVES BUILT-IN with UNATTACHED CONDENSER/CONTROL BOX

Model *	Overall Shelf Dim. (includes brackets)	Usable Space	List Price
	W x D	W x D	
<b>CSSBR-2418</b>	686 x 533 mm	610 x 457 mm	<b>\$5338</b>
<b>CSSBR-3018</b>	383 x 533 mm	762 x 457 mm	<b>5392</b>
<b>CSSBR-3618</b>	991 x 533 mm	914 x 457 mm	<b>5575</b>
<b>CSSBR-4818</b>	1295 x 533 mm	1219 x 457 mm	<b>6389</b>

\* Not available with CE Mark.

Consult factory for refrigerant specifications.

**All Cold Simulated Stone Shelf Built-In with Unattached Condenser/Control Box Models Feature:**

**Voltage:** 220, 230 or 240 (CE not available). **Models Shipped with:** Shelf assembly with temperature probe, Control Box and condensing unit (shipped loose), TVX valve (unattached).

### COLD SIMULATED STONE SHELVES BUILT-IN with UNATTACHED CONTROL BOX only

Model *	Overall Shelf Dim. (includes brackets)	Usable Space	Watts	Approx. Ship Weight	List Price
	W x D	W x D	220V, 230V, 240V		
<b>CSSBX-2418</b>	686 x 533 mm	610 x 457 mm	17	35 kg	<b>\$4094</b>
<b>CSSBX-3018</b>	383 x 533 mm	762 x 457 mm	17	40 kg	<b>4149</b>
<b>CSSBX-3618</b>	991 x 533 mm	914 x 457 mm	17	45 kg	<b>4332</b>
<b>CSSBX-4818</b>	1295 x 533 mm	1219 x 457 mm	17	68 kg	<b>5146</b>

\* Not available with CE Mark.

**All Cold Simulated Stone Shelf Built-In With Unattached Control Box Only Models Feature:**

**Voltage:** 220, 230 or 240 (CE not available). **Models Shipped with:** Shelf assembly with temperature probe, solenoid valve (attached to shelf), Control Box (shipped loose), TVX valve (unattached).

**NOTE:** All models are not a CE offering, items are sold as components for fabricator self certification.

### COUNTERTOP CUTOUT DIMENSIONS

Model	Width with 10 mm radii	Depth with 10 mm radii
<b>CSSB(R)(X)-2418</b>	619 mm	467 mm
<b>CSSB(R)(X)-3018</b>	772 mm	467 mm
<b>CSSB(R)(X)-3618</b>	924 mm	467 mm
<b>CSSB(R)(X)-4818</b>	1229 mm	467 mm

Model	Width	Height
<b>Control Box</b>	242 mm	197 mm

### OPTIONS

(available at time of purchase only)

**Simulated stone colors –**

**Non-standard colors are non-returnable – Night Sky Standard –**

**SS-GGRAN** Gray Granite **No Charge**  
**SS-BSAND** Bermuda Sand **No Charge**

**COLORS – INSIDE BACK COVER**

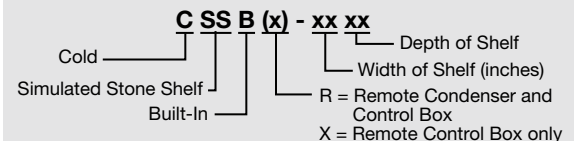

## Cold Simulated Stone Shelves Built-In Flush Top

Hatco's new sturdy Cold Simulated Stone Shelves Built-In Flush Top are a must for buffet lines in cafeterias, restaurants and more!

- Patented thermal break reduces condensation and temperature transfer on adjacent surfaces
- Simulated stone is Swanstone®
- All models are bottom mount units
- Control Box comes Standard with a 1219 mm lead wire
- Control Box can be mounted 1219 mm from center of the shelf (CSSBF models only)
- CSSBF models offer a long, flexible refrigerant line which allows condensing unit to be pulled out for service
- Condensing unit features easy serviceability with sight glass, service valves, dryer/filter and receiver (CSSBF, CSSBFR models only)

*continued on next page...*



**CSSBF-48-S**  
in Standard Night Sky simulated stone



**CSSBFR-48-S**  
in optional Bermuda Sand – All models come with unattached Condenser and Control Box

### COLD SIMULATED STONE SHELVES BUILT-IN FLUSH TOP

Model *	Overall Shelf Dim. (includes brackets)		Usable Space W x D	List Price
	W x D	W x D		
CSSBF-24-F	686 x 470 mm	610 x 394 mm		<b>\$6051</b>
CSSBF-24-I	686 x 572 mm	610 x 495 mm		<b>6073</b>
CSSBF-24-S	686 x 686 mm	610 x 610 mm		<b>6259</b>
CSSBF-36-F	991 x 470 mm	914 x 394 mm		<b>6276</b>
CSSBF-36-I	991 x 572 mm	914 x 495 mm		<b>6300</b>
CSSBF-36-S	991 x 686 mm	914 x 610 mm		<b>7366</b>
CSSBF-48-F	1295 x 470 mm	1219 x 394 mm		<b>7086</b>
CSSBF-48-I	1295 x 572 mm	1219 x 495 mm		<b>7113</b>
CSSBF-48-S	1295 x 686 mm	1219 x 610 mm		<b>8287</b>

\* Not available with CE Mark.

Consult factory for refrigerant specifications.

**All Cold Simulated Stone Shelf Built-In Flush Top Models Feature:**

Voltage: 220, 230 or 240 (CE not available).

Models Shipped with: Electronic Temperature Control and condensing unit, 1829 mm cord and plug.

**NOTE:** Models are not a CE offering, items are sold as components for fabricator self certification.

### COLD SIMULATED STONE SHELVES BUILT-IN FLUSH TOP with UNATTACHED CONDENSER/CONTROL BOX

Model *	Overall Shelf Dim. (includes brackets)		Usable Space W x D	List Price
	W x D	W x D		
CSSBFR-24-F	686 x 470 mm	610 x 394 mm		<b>\$5326</b>
CSSBFR-24-I	686 x 572 mm	610 x 495 mm		<b>5348</b>
CSSBFR-24-S	686 x 686 mm	610 x 610 mm		<b>5534</b>
CSSBFR-36-F	991 x 470 mm	914 x 394 mm		<b>5551</b>
CSSBFR-36-I	991 x 572 mm	914 x 495 mm		<b>5575</b>
CSSBFR-36-S	991 x 686 mm	914 x 610 mm		<b>6641</b>
CSSBFR-48-F	1295 x 470 mm	1219 x 394 mm		<b>6361</b>
CSSBFR-48-I	1295 x 572 mm	1219 x 495 mm		<b>6388</b>
CSSBFR-48-S	1295 x 686 mm	1219 x 610 mm		<b>7562</b>

\* Not available with CE Mark.

Consult factory for refrigerant specifications.

**All Cold Simulated Stone Shelf Built-In Flush Top with Unattached Condenser/Control Box Models Feature:**

Voltage: 220, 230 or 240 (CE not available).

Models Shipped with: Shelf assembly with temperature probe, Control Box and condensing unit (shipped loose), TXV valve (unattached).

**OPTIONS – PAGE 100**



## Cold Simulated Stone Shelves Built-In Flush Top

continued...

- CSSBR models have unattached Condensing unit and Control Box, CSSBX models have unattached Control Box only
- CSSBFR, CSSBFX models have benefit of allowing fabricators the freedom to design



**CSSBFX-48-S**  
in optional Gray Granite simulated stone – All models come with unattached Control Box only

### COLD SIMULATED STONE SHELVES BUILT-IN FLUSH TOP with UNATTACHED CONTROL BOX only

Model *	Overall Shelf Dim. (includes brackets) W x D	Usable Space W x D	Watts		List Price
			220V, 230V, 240V	Approx. Ship Weight	
CSSBFX-24-F	686 x 470 mm	610 x 394 mm	17	35 kg	\$4083
CSSBFX-24-I	686 x 572 mm	610 x 495 mm	17	36 kg	4105
CSSBFX-24-S	686 x 686 mm	610 x 610 mm	17	41 kg	4291
CSSBFX-36-F	991 x 470 mm	914 x 394 mm	17	44 kg	4308
CSSBFX-36-I	991 x 572 mm	914 x 495 mm	17	50 kg	4332
CSSBFX-36-S	991 x 686 mm	914 x 610 mm	17	56 kg	5398
CSSBFX-48-F	1295 x 470 mm	1219 x 394 mm	17	53 kg	5118
CSSBFX-48-I	1295 x 572 mm	1219 x 495 mm	17	56 kg	5145
CSSBFX-48-S	1295 x 686 mm	1219 x 610 mm	17	64 kg	6319

\* Not available with CE Mark.

All Cold Simulated Stone Shelf Built-In Flush Top with Unattached Control Box Only Models Feature:

Voltage: 220, 230 or 240 (CE not available).

Models Shipped with: Shelf assembly with temperature probe, solenoid valve (attached to shelf), Control Box (shipped loose) TXV valve (unattached).

NOTE: Models are not a CE offering, items are sold as components for fabricator self certification.

### COUNTERTOP CUTOUT DIMENSIONS

Model	Width with 10 mm radii	Depth with 10 mm radii
CSSBF(R)(X)-24-F	619 mm	403 mm
CSSBF(R)(X)-24-I	619 mm	505 mm
CSSBF(R)(X)-24-S	619 mm	619 mm
CSSBF(R)(X)-36-F	924 mm	403 mm
CSSBF(R)(X)-36-I	924 mm	505 mm
CSSBF(R)(X)-36-S	924 mm	619 mm
CSSBF(R)(X)-48-F	1229 mm	403 mm
CSSBF(R)(X)-48-I	1229 mm	505 mm
CSSBF(R)(X)-48-S	1229 mm	619 mm

Model	Width	Height
Control Box	242 mm	197 mm

### OPTIONS (available at time of purchase only)

Simulated stone colors – Non-standard colors are non-returnable – Night Sky Standard –

SS-GGRAN	Gray Granite	No Charge
SS-BSAND	Bermuda Sand	No Charge

### COLORS – INSIDE BACK COVER

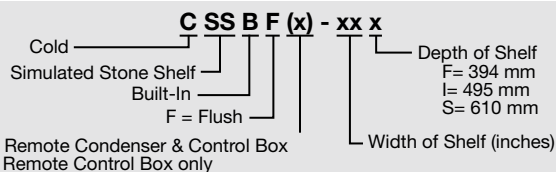



## Cold Shelves Built-In Flush Top

Hatco's Cold Built-In Flush Top Shelves, in our signature aluminium hardcoat, are designed to keep your pre-chilled beverages, hors d'oeuvres, side dishes, buffet items and more, perfectly chilled.

- Patented thermal break reduces condensation and temperature transfer on adjacent surfaces
- All models are top mounted with a aluminum hardcoat surface
- All models match the GRSBF Heated Built-In Shelves for a fully integrated look
- Control comes Standard with a 1219 mm lead wire
- Control Box can be mounted 1219 mm from center of shelf (CSBF models only)
- CSBF models offer a long, flexible refrigerant line which allows condensing unit to be pulled out for service
- Condensing unit features easy serviceability with sight glass, service valves, dryer/filter and receiver (CSBF, CSBFR models only)

*continued on next page...*



**CSBF-48-S**  
(Flush Top)



**CSBFR-48-S**  
(Flush Top) All models come with unattached Condenser and Control Box

### COLD SHELVES BUILT-IN FLUSH TOP (Hardcoat Aluminum)

Model *	Overall Shelf Dimensions	Usable Shelf Space	List Price
	W x D	W x D	
CSBF-24-F	648 x 432 mm	610 x 394 mm	<b>\$5835</b>
CSBF-24-I	648 x 533 mm	610 x 495 mm	<b>5855</b>
CSBF-24-S	648 x 648 mm	610 x 610 mm	<b>5932</b>
CSBF-36-F	953 x 432 mm	914 x 394 mm	<b>5950</b>
CSBF-36-I	953 x 533 mm	914 x 495 mm	<b>5972</b>
CSBF-36-S	953 x 648 mm	914 x 610 mm	<b>6788</b>
CSBF-48-F	1257 x 432 mm	1219 x 394 mm	<b>6652</b>
CSBF-48-I	1257 x 533 mm	1219 x 495 mm	<b>6677</b>
CSBF-48-S	1257 x 648 mm	1219 x 610 mm	<b>7362</b>

\* Not available with CE Mark.

Consult factory for refrigerant specifications.

**All Cold Shelf Built-In Flush Top Models Feature:**

Voltage: 220, 230 or 240 (CE not available).

Models Shipped with: Electronic Temperature Control and condensing unit, 1829 mm cord and plug.

**NOTE:** Models are not a CE offering, items are sold as components for fabricator self certification.

### COLD SHELVES BUILT-IN FLUSH TOP (Hardcoat Aluminum) with UNATTACHED CONDENSER/CONTROL BOX

Model *	Overall Shelf Dimensions	Usable Shelf Space	List Price
	W x D	W x D	
CSBFR-24-F	648 x 432 mm	610 x 394 mm	<b>\$5238</b>
CSBFR-24-I	648 x 533 mm	610 x 495 mm	<b>5259</b>
CSBFR-24-S	648 x 648 mm	610 x 610 mm	<b>5335</b>
CSBFR-36-F	953 x 432 mm	914 x 394 mm	<b>5353</b>
CSBFR-36-I	953 x 533 mm	914 x 495 mm	<b>5375</b>
CSBFR-36-S	953 x 648 mm	914 x 610 mm	<b>6191</b>
CSBFR-48-F	1257 x 432 mm	1219 x 394 mm	<b>6055</b>
CSBFR-48-I	1257 x 533 mm	1219 x 495 mm	<b>6080</b>
CSBFR-48-S	1257 x 648 mm	1219 x 610 mm	<b>6765</b>

\* Not available with CE Mark.

Consult factory for refrigerant specifications.

**All Cold Shelf Built-In Flush Top with Unattached Condenser/Control Box Models Feature:**

Voltage: 220, 230 or 240 (CE not available).

Models Shipped with: Shelf assembly with temperature probe, Control Box and condensing unit (shipped loose), TXV valve (unattached).

## Cold Shelves Built-In Flush Top

continued

- CSBFR models have unattached Condensing unit and Control Box, CSBFX models have unattached Control Box only
- CSBFR, CSBFX models have benefit of allowing fabricators the freedom to design



**CSBFX-48-S**  
(Flush Top) All models come with unattached Control Box only

**COLD SHELVES BUILT-IN FLUSH TOP (Hardcoat Aluminum) with UNATTACHED CONTROL BOX only**

Model *	Overall Shelf Dimensions W x D	Usable Shelf Space W x D	Rated Watts	Approx. Ship Weight	List Price 220V, 230V, 240V
CSBFX-24-F	648 x 432 mm	610 x 394 mm	17	29 kg	<b>\$3867</b>
CSBFX-24-I	648 x 533 mm	610 x 495 mm	17	33 kg	<b>3888</b>
CSBFX-24-S	648 x 648 mm	610 x 610 mm	17	36 kg	<b>3964</b>
CSBFX-36-F	953 x 432 mm	914 x 394 mm	17	35 kg	<b>3982</b>
CSBFX-36-I	953 x 533 mm	914 x 495 mm	17	41 kg	<b>4004</b>
CSBFX-36-S	953 x 648 mm	914 x 610 mm	17	50 kg	<b>4820</b>
CSBFX-48-F	1257 x 432 mm	1219 x 394 mm	17	43 kg	<b>4684</b>
CSBFX-48-I	1257 x 533 mm	1219 x 495 mm	17	47 kg	<b>4709</b>
CSBFX-48-S	1257 x 648 mm	1219 x 610 mm	17	56 kg	<b>5394</b>

\* Not available with CE Mark.

All Cold Shelf Built-In Flush Top with Unattached Control Box Only Models Feature:

Voltage: 220, 230 or 240 (CE not available).

Models Shipped with: Shelf assembly with temperature probe, solenoid valve (attached to shelf), Control Box (shipped loose), TXV valve (unattached).

**NOTE:** Models are not a CE offering, items are sold as components for fabricator self certification.

**COUNTERTOP CUTOUT DIMENSIONS**

Model	Width		Depth	
	Minimum	Maximum	Minimum	Maximum
CSBF(X)(R)-24-F	625 mm	635 mm	409 mm	419 mm
CSBF(X)(R)-24-I	625 mm	635 mm	511 mm	521 mm
CSBF(X)(R)-24-S	625 mm	635 mm	625 mm	635 mm
CSBF(X)(R)-36-F	930 mm	940 mm	409 mm	419 mm
CSBF(X)(R)-36-I	930 mm	940 mm	511 mm	521 mm
CSBF(X)(R)-36-S	930 mm	940 mm	625 mm	635 mm
CSBF(X)(R)-48-F	1234 mm	1245 mm	409 mm	419 mm
CSBF(X)(R)-48-I	1234 mm	1245 mm	511 mm	521 mm
CSBF(X)(R)-48-S	1234 mm	1245 mm	625 mm	635 mm
<b>Control Box</b>	242 mm		197 mm	

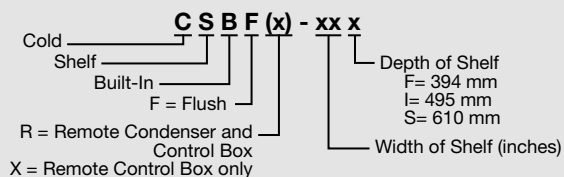

## Cold Shelves Undermount

Cold Shelves Undermount offer the same great performance as the Cold Built-In Flush Top Shelves, but are mounted directly against the underside of a granite, quartz, stainless steel or appropriate simulated stone countertop (no cut out required). Cooling transfers through the countertop to the top surface, without puncturing, for a true, seamless look.

- Mount under appropriate countertop material for a seamless look
- Approved materials include granite and quartz up to 30 mm, Swanstone as provided by Hatco, and certain stainless steel or aluminum surfaces approved by Hatco. Please contact the factory for applications with other material. \*
- All models feature an Anodized Aluminum surface
- Control Box comes Standard with a 1219 mm lead wire
- Control Box can be mounted 1219 mm from center of the shelf (CSU models only)
- CSU models offer a long, flexible refrigerant line which allows condensing unit to be pulled out for service
- Condensing unit features easy serviceability with sight glass, service valves, dryer/filter and receiver (CSU, CSUR models only)

*continued on next page...*



**CSU-48-S**  
(Undermount)

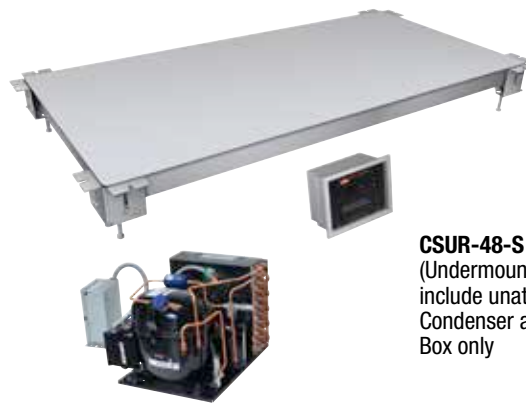

**CSUR-48-S**  
(Undermount) All models include unattached Condenser and Control Box only

### COLD SHELVES UNDERMOUNT (Anodized Aluminum)

Model *	Overall Shelf Dim. (includes brackets) W x D	Shelf Space W x D	List Price
CSU-24-F	694 x 478 mm	610 x 394 mm	\$5508
CSU-24-I	694 x 579 mm	610 x 495 mm	5529
CSU-24-S	694 x 694 mm	610 x 610 mm	5581
CSU-36-F	998 x 478 mm	914 x 394 mm	5495
CSU-36-I	998 x 579 mm	914 x 495 mm	5505
CSU-36-S	998 x 694 mm	914 x 610 mm	6224
CSU-48-F	1303 x 478 mm	1219 x 394 mm	6076
CSU-48-I	1303 x 579 mm	1219 x 495 mm	6100
CSU-48-S	1303 x 694 mm	1219 x 610 mm	6612

\* Not available with CE Mark.

Consult factory for refrigerant specifications.

**All Cold Shelf Undermount Models Feature:**

**Voltage:** 220, 230 or 240 (CE not available).

**Models Shipped with:** Electronic Temperature Control and condensing unit, 1829 mm cord and plug.

### COLD SHELVES UNDERMOUNT (Anodized Aluminum) with UNATTACHED CONDENSER/CONTROL BOX

Model *	Overall Shelf Dim. (includes brackets) W x D	Shelf Space W x D	List Price
CSUR-24-F	694 x 478 mm	610 x 394 mm	\$4783
CSUR-24-I	694 x 579 mm	610 x 495 mm	4804
CSUR-24-S	694 x 694 mm	610 x 610 mm	4856
CSUR-36-F	998 x 478 mm	914 x 394 mm	4770
CSUR-36-I	998 x 579 mm	914 x 495 mm	4780
CSUR-36-S	998 x 694 mm	914 x 610 mm	5499
CSUR-48-F	1303 x 478 mm	1219 x 394 mm	5351
CSUR-48-I	1303 x 579 mm	1219 x 495 mm	5375
CSUR-48-S	1303 x 694 mm	1219 x 610 mm	5887

\* Not available with CE Mark.

Consult factory for refrigerant specifications.

**All Cold Shelf Undermount with Unattached Condenser/Control Box Models Feature:**

**Voltage:** 220, 230 or 240 (CE not available).

**Models Shipped with:** Shelf assembly with temperature probe, Control Box and condensing unit (shipped loose), TXV valve (unattached).

\* Make structural modifications or add bracing underneath the countertop to ensure countertop will support the weight of the unit and its contents.

**NOTE:** Models are not a CE offering, items are sold as components for fabricator self certification.

## Cold Shelves Undermount

continued

- CSUR models have unattached Condensing unit and Control Box, CSUX models have unattached Control Box only
- CSUR and CSUX models have benefit of allowing fabricators the freedom to design.



**CSUX-48-S**  
(Undermount) All models include unattached Control Box only

### COLD SHELVES UNDERMOUNT (Anodized Aluminum) with UNATTACHED CONTROL BOX only

Model *	Overall Shelf Dim. (includes brackets) W x D	Shelf Space W x D	Watts	Approx. Ship Weight	List Price 220V, 230V, 240V
CSUX-24-F	694 x 478 mm	610 x 394 mm	17	34 kg	<b>\$3540</b>
CSUX-24-I	694 x 579 mm	610 x 495 mm	17	33 kg	<b>3561</b>
CSUX-24-S	694 x 694 mm	610 x 610 mm	17	39 kg	<b>3613</b>
CSUX-36-F	998 x 478 mm	914 x 394 mm	17	45 kg	<b>3527</b>
CSUX-36-I	998 x 579 mm	914 x 495 mm	17	44 kg	<b>3537</b>
CSUX-36-S	998 x 694 mm	914 x 610 mm	17	45 kg	<b>4256</b>
CSUX-48-F	1303 x 478 mm	1219 x 394 mm	17	44 kg	<b>4108</b>
CSUX-48-I	1303 x 579 mm	1219 x 495 mm	17	59 kg	<b>4132</b>
CSUX-48-S	1303 x 694 mm	1219 x 610 mm	17	45 kg	<b>4644</b>

**NOTE:** Models are not a CE offering, items are sold as components for fabricator self certification.

\* Not available with CE Mark.

**All Cold Shelf Undermount with Unattached Control Box Only Models Feature:**

**Voltage:** 220, 230 or 240 (CE not available).

**Models Shipped with:** Shelf assembly with temperature probe, solenoid valve (attached to shelf), Control Box (shipped loose), TXV valve (unattached).

\* Make structural modifications or add bracing underneath the countertop to ensure countertop will support the weight of the unit and its contents.

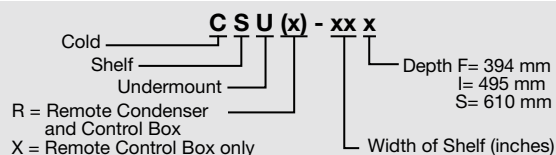





## Hot/Cold Simulated Stone Shelves Built-In

Give your operation ultimate flexibility with Hatco's innovative, patented, Hot/Cold Simulated Stone Shelves Built-In. They easily transition between a heated to cold and cold to heated shelf!

- Patented thermal break reduces condensation and temperature transfer on adjacent surfaces
- Shelves change modes from hot to cold or vice versa in as little as 30 minutes, allowing quick change for different dayparts
- All models are bottom mount, flush with the countertop
- Simulated stone is Swanstone®
- All models match the GRSSB Heated Built-In Shelves for an fully integrated look
- Control Box can be mounted 1219 mm from center of shelf (HCSSB models only)
- HCSSB models offer a long, flexible refrigerant line which allows condensing unit to be pulled out for service
- Condensing unit features easy serviceability with sight glass, service valves, dryer/filter and receiver (HCSSB, HCSSBR models only)
- HCSSBR has unattached Condensing unit and Control Box, HCSSBX has unattached Control Box only



**HCSSB-4818**  
in optional Bermuda Sand simulated stone



**HCSSBR-4818**  
in Standard Night Sky simulated stone – All models include unattached Condenser and Control Box only



**HCSSBX-4818**  
in optional Granite Gray simulated stone – All models include unattached Control Box only

### HOT/COLD SIMULATED STONE SHELVES BUILT-IN (flush to countertop)

Model *	Overall Shelf Dim. (includes brackets) W x D	Shelf Space W x D	List Price
HCSSB-2418	686 x 533 mm	610 x 457 mm	\$6987
HCSSB-3018	838 x 533 mm	762 x 457 mm	7055
HCSSB-3618	991 x 533 mm	914 x 457 mm	7178
HCSSB-4818	1295 x 533 mm	1219 x 457 mm	7883

\* Not available with CE Mark.

Consult factory for refrigerant specifications.

All Hot/Cold Simulated Stone Shelf Built-In Models Feature:

Voltage: 220, 230 or 240 (CE not available). Models Shipped with: Electronic Temperature Control, condensing unit, 1829 mm cord and plug.

### HOT/COLD SIMULATED STONE SHELVES BUILT-IN with UNATTACHED CONDENSER/CONTROL BOX

Model *	Overall Shelf Dim. (includes brackets) W x D	Shelf Space W x D	List Price
HCSSBR-2418	686 x 533 mm	610 x 457 mm	\$6262
HCSSBR-3018	838 x 533 mm	762 x 457 mm	6330
HCSSBR-3618	991 x 533 mm	914 x 457 mm	6453
HCSSBR-4818	1295 x 533 mm	1219 x 457 mm	7159

\* Not available with CE Mark.

Consult factory for refrigerant specifications.

All Hot/Cold Simulated Stone Shelf Built-In with Unattached Condenser/Control Box Models Feature:

Voltage: 220, 230 or 240 (CE not available). Models Shipped with: Shelf assembly with temperature probes, Control Box and condensing unit (shipped loose), unattached TXV valve.

### HOT/COLD SIMULATED STONE SHELVES BUILT-IN with UNATTACHED CONTROL BOX only

Model *	Overall Shelf Dim. (includes brackets) W x D	Shelf Space W x D	Hot Side Watts 220V, 230V, 240V	Approx. Ship Weight	List Price
HCSSBX-2418	686 x 533 mm	610 x 457 mm	371, 405, 441	35 kg	\$5019
HCSSBX-3018	838 x 533 mm	762 x 457 mm	467, 510, 555	48 kg	5087
HCSSBX-3618	991 x 533 mm	914 x 457 mm	558, 610, 664	53 kg	5210
HCSSBX-4818	1295 x 533 mm	1219 x 457 mm	746, 815, 887	64 kg	5916

\* Not available with CE Mark.

All Hot/Cold Simulated Stone Shelf Built-In with Control Box Only Models Feature:

Voltage: 220, 230 or 240 (CE not available). Models Shipped with: Shelf assembly with temperature probes, solenoid valve (attached to shelf), Control Box (shipped loose), TXV valve (unattached).

**NOTE:** Models are not a CE offering, items are sold as components for fabricator self certification.

### COUNTERTOP CUTOUT DIMENSIONS

Model	Width 10 mm radii	Depth 10 mm radii
HCSSB(R)(X)-2418	619 mm	467 mm
HCSSB(R)(X)-3018	772 mm	467 mm
HCSSB(R)(X)-3618	924 mm	467 mm
HCSSB(R)(X)-4818	1229 mm	467 mm
Model	Width	Height
Control Box	372 mm	197 mm

### OPTIONS

(available at time of purchase only)

Simulated stone colors – Non-standard colors are non-returnable – Night Sky Standard –

SS-GGRAN Gray Granite No Charge  
SS-BSAND Bermuda Sand No Charge

### COLORS – INSIDE BACK COVER

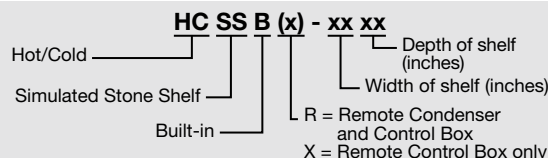

## Hot/Cold Simulated Stone Shelves Built-In Flush Top

Give your operation ultimate flexibility with Hatco's innovative, patented Hot/Cold Simulated Stone Shelves Built-in Flush Top. They easily transition between a heated to cold and cold to heated shelf!

- Patented thermal break reduces condensation and temperature transfer on adjacent surfaces
- Shelves change modes from hot to cold or vice versa in as little as 30 minutes, allowing quick change for different dayparts
- All units are bottom mount, flush with the countertop
- Simulated stone is Swanstone®
- All units match the GRSSBF Heated Built-In Shelves for an integrated look
- Control Box comes Standard with a 1219 mm lead wire
- Control Box can be mounted 1219 mm from center of shelf (HCSSBF models only)
- HCSSBF models offer a long, flexible refrigerant line which allows condensing unit to be pulled out for service
- Condensing unit features easy serviceability with sight glass, service valves, dryer/filter and receiver (HCSSBF, HCSSBFR models only)

*continued on next page...*



**HCSSBF-48-S**  
in Standard Night Sky simulated stone

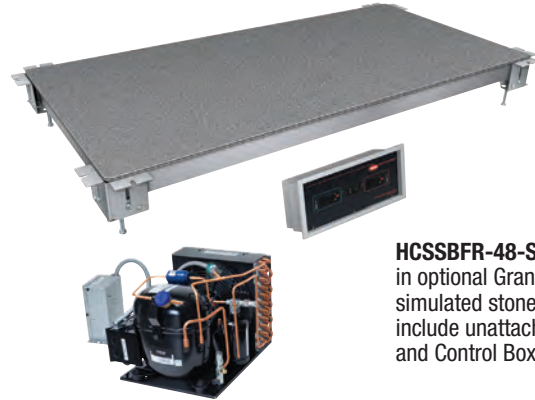

**HCSSBFR-48-S**  
in optional Granite Gray simulated stone – All models include unattached Condenser and Control Box only

### HOT/COLD SIMULATED STONE SHELVES BUILT-IN FLUSH TOP

Model *	Overall Shelf Dim. (includes brackets) W x D	Shelf Space W x D	List Price
HCSSBF-24-F	686 x 470 mm	610 x 394 mm	\$6960
HCSSBF-24-I	686 x 572 mm	610 x 495 mm	6987
HCSSBF-24-S	686 x 686 mm	610 x 610 mm	7049
HCSSBF-36-F	991 x 470 mm	914 x 394 mm	7152
HCSSBF-36-I	991 x 572 mm	914 x 495 mm	7178
HCSSBF-36-S	991 x 686 mm	914 x 610 mm	7986
HCSSBF-48-F	1295 x 470 mm	1219 x 394 mm	7391
HCSSBF-48-I	1295 x 572 mm	1219 x 495 mm	7925
HCSSBF-48-S	1295 x 686 mm	1219 x 610 mm	9483

\* Not available with CE Mark.

Consult factory for refrigerant specifications.

**All Hot/Cold Simulated Stone Shelf Built-In Flush Top Models Feature:**

**Voltage:** Voltage: 220, 230 or 240 (CE not available).

**Models Shipped with:** Electronic Temperature Control and condensing unit, 1829 mm cord and plug.

**NOTE:** Models are not a CE offering, items are sold as components for fabricator self certification.

### HOT/COLD SIMULATED STONE SHELVES BUILT-IN FLUSH TOP with UNATTACHED CONDENSER/CONTROL BOX

Model *	Overall Shelf Dim. (includes brackets) W x D	Shelf Space W x D	List Price
HCSSBFR-24-F	686 x 470 mm	610 x 394 mm	\$6235
HCSSBFR-24-I	686 x 572 mm	610 x 495 mm	6262
HCSSBFR-24-S	686 x 686 mm	610 x 610 mm	6325
HCSSBFR-36-F	991 x 470 mm	914 x 394 mm	6427
HCSSBFR-36-I	991 x 572 mm	914 x 495 mm	6453
HCSSBFR-36-S	991 x 686 mm	914 x 610 mm	7262
HCSSBFR-48-F	1295 x 470 mm	1219 x 394 mm	6666
HCSSBFR-48-I	1295 x 572 mm	1219 x 495 mm	7200
HCSSBFR-48-S	1295 x 686 mm	1219 x 610 mm	8758

\* Not available with CE Mark.

Consult factory for refrigerant specifications.

**All Hot/Cold Simulated Stone Shelf Built-In Flush Top with Unattached Condenser/Control Box Models Feature:**

**Voltage:** 220, 230 or 240 (CE not available).

**Models Shipped with:** Shelf assembly with temperature probes, Control Box and condensing unit (shipped loose), TXV valve (unattached).

**OPTIONS – PAGE 107**



## Hot/Cold Simulated Stone Shelves Built-In Flush

continued

- HCSSBFR has unattached Condensing unit and Control Box, HCSSBFX has unattached Control Box only
- HCSSBFR and HCSSBFX models have benefit of allowing fabricators the freedom to design



**HCSSBFX-48-S**  
in optional Bermuda Sand simulated stone – All models include unattached Control Box only

**HOT/COLD SIMULATED STONE SHELVES BUILT-IN FLUSH TOP with UNATTACHED CONTROL BOX only**

Model *	Overall Shelf Dim. (includes brackets) W x D	Shelf Space W x D	Hot Side Watts 220V, 230V, 240V	Approx. Ship Weight	List Price
HCSSBFX-24-F	686 x 470 mm	610 x 394 mm	325, 355, 387	32 kg	\$4992
HCSSBFX-24-I	686 x 572 mm	610 x 495 mm	407, 445, 485	40 kg	5019
HCSSBFX-24-S	686 x 686 mm	610 x 610 mm	503, 550, 599	48 kg	5081
HCSSBFX-36-F	991 x 470 mm	914 x 394 mm	485, 530, 577	46 kg	5184
HCSSBFX-36-I	991 x 572 mm	914 x 495 mm	613, 670, 730	56 kg	5210
HCSSBFX-36-S	991 x 686 mm	914 x 610 mm	755, 825, 898	62 kg	6018
HCSSBFX-48-F	1295 x 470 mm	1219 x 394 mm	650, 710, 773	59 kg	5423
HCSSBFX-48-I	1295 x 572 mm	1219 x 495 mm	814, 890, 969	77 kg	5957
HCSSBFX-48-S	1295 x 686 mm	1219 x 610 mm	1006, 1100, 1198	75 kg	7515

\* Not available with CE Mark.

All Hot/Cold Simulated Stone Shelf Built-In Flush Top with Unattached Control Box Only

Models Feature:

Voltage: 220, 230 or 240 (CE not available).

Models Shipped with: Shelf assembly with temperature probe, solenoid valve (attached to shelf), Control Box (shipped loose) TXV valve (unattached).

**NOTE:** Models are not a CE offering, items are sold as components for fabricator self certification.

**COUNTERTOP CUTOUT DIMENSIONS**

Model	Width 10 mm radii	Depth 10 mm radii
HCSSBF(R)(X)-24-F	619 mm	403 mm
HCSSBF(R)(X)-24-I	619 mm	505 mm
HCSSBF(R)(X)-24-S	619 mm	619 mm
HCSSBF(R)(X)-36-F	921 mm	403 mm
HCSSBF(R)(X)-36-I	921 mm	505 mm
HCSSBF(R)(X)-36-S	921 mm	619 mm
HCSSBF(R)(X)-48-F	1226 mm	403 mm
HCSSBF(R)(X)-48-I	1226 mm	505 mm
HCSSBF(R)(X)-48-S	1226 mm	619 mm

Model	Width	Height
Control Box	372 mm	197 mm

**OPTIONS**

(available at time of purchase only)

Simulated stone colors – Non-standard colors are non-returnable – Night Sky Standard –

SS-GGRAN	Gray Granite	No Charge
SS-BSAND	Bermuda Sand	No Charge

**COLORS – INSIDE BACK COVER**

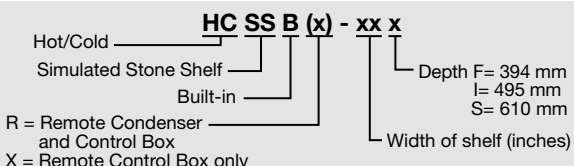

## Hot/Cold Shelves Built-In Flush Top

Give your operation ultimate flexibility with Hatco's innovative, patented Hot/Cold Shelves Built-In Shelves. In our signature aluminium hardcoat, they easily transition between a heated to cold and cold to heated shelf!

- Patented thermal break reduces condensation and temperature transfer on adjacent surfaces
  - Shelves change modes from hot to cold or vice versa in as little as 30 minutes, allowing quick change for different dayparts
  - Units are hardcoat aluminum, top mount
  - All models match the GRSBF Heated Built-In Shelves for a fully integrated look
  - Control comes Standard with a 1219 mm lead wire
  - Control Box can be mounted 1219 mm from center of shelf (HCSBF models only)
  - HCSBF models offer a long, flexible refrigerant line which allows condensing unit to be pulled out for service
  - Condensing unit features easy serviceability with sight glass, service valves, dryer/filter and receiver (HCSBF, HCSBFR models only)
- continued on next page...*



HCSBF-48-S



HCSBFR-48-S All models include unattached Condenser and Control Box only

### HOT/COLD SHELVES BUILT-IN FLUSH TOP (Aluminum Hardcoat)

Model *	Overall Shelf Dimensions W x D	Usable Shelf Space W x D	List Price
HCSBF-24-F	648 x 432 mm	610 x 394 mm	\$6761
HCSBF-24-I	648 x 533 mm	610 x 495 mm	6787
HCSBF-24-S	648 x 648 mm	610 x 610 mm	6875
HCSBF-36-F	953 x 432 mm	914 x 394 mm	6963
HCSBF-36-I	953 x 533 mm	914 x 495 mm	6977
HCSBF-36-S	953 x 648 mm	914 x 610 mm	7807
HCSBF-48-F	1257 x 432 mm	1219 x 394 mm	7751
HCSBF-48-I	1257 x 533 mm	1219 x 495 mm	7765
HCSBF-48-S	1257 x 648 mm	1219 x 610 mm	8450

\* Not available with CE Mark.

Consult factory for refrigerant specifications.

**All Hot/Cold Shelf Built-In Flush Top Models Feature:**

Voltage: 220, 230 or 240 (CE not available).

Models Shipped with: Electronic Temperature Control, condensing unit, 1829 mm cord and plug.

### HOT/COLD SHELVES BUILT-IN FLUSH TOP (Aluminum Hardcoat) with UNATTACHED CONDENSER/CONTROL BOX

Model *	Overall Shelf Dimensions W x D	Usable Shelf Space W x D	List Price
HCSBFR-24-F	648 x 432 mm	610 x 394 mm	\$6164
HCSBFR-24-I	648 x 533 mm	610 x 495 mm	6190
HCSBFR-24-S	648 x 648 mm	610 x 610 mm	6278
HCSBFR-36-F	953 x 432 mm	914 x 394 mm	6366
HCSBFR-36-I	953 x 533 mm	914 x 495 mm	6380
HCSBFR-36-S	953 x 648 mm	914 x 610 mm	7210
HCSBFR-48-F	1257 x 432 mm	1219 x 394 mm	7154
HCSBFR-48-I	1257 x 533 mm	1219 x 495 mm	7168
HCSBFR-48-S	1257 x 648 mm	1219 x 610 mm	7853

\* Not available with CE Mark.

Consult factory for refrigerant specifications.

**All Hot/Cold Shelf Built-In Flush Top wWith Unattached Condenser/Control Box Models Feature:**

Voltage: 220, 230 or 240 (CE not available).

Models Shipped with: Shelf assembly with temperature probes, Control Box and condensing unit (shipped loose), TXV valve (unattached).





## Hot/Cold Simulated Stone Shelves Built-In Flush

continued

- HCSBFR models have unattached Condensing unit and Control Box, HCSBFX models have unattached Control Box only
- HCSBFR and HCSBFX models have benefit of allowing fabricators the freedom to design.



**HCSBFX-48-S**  
All models include unattached Control Box only

**HOT/COLD SHELVES BUILT-IN FLUSH TOP (Aluminum Hardcoat) with UNATTACHED CONTROL BOX only**

Model *	Overall Dimensions	Usable Space	Hot Side Watts	Approx. Ship	List Price
	W x D	W x D	220V, 230V, 240V	Weight	
HCSBFX-24-F	648 x 432 mm	610 x 394 mm	325, 355, 387	34 kg	<b>\$4793</b>
HCSBFX-24-I	648 x 533 mm	610 x 495 mm	407, 445, 485	39 kg	<b>4819</b>
HCSBFX-24-S	648 x 648 mm	610 x 610 mm	503, 550, 599	44 kg	<b>4907</b>
HCSBFX-36-F	953 x 432 mm	914 x 394 mm	485, 530, 577	48 kg	<b>4995</b>
HCSBFX-36-I	953 x 533 mm	914 x 495 mm	613, 670, 730	52 kg	<b>5009</b>
HCSBFX-36-S	953 x 648 mm	914 x 610 mm	755, 825, 898	53 kg	<b>5839</b>
HCSBFX-48-F	1257 x 432 mm	1219 x 394 mm	650, 710, 773	55 kg	<b>5783</b>
HCSBFX-48-I	1257 x 533 mm	1219 x 495 mm	814, 890, 969	58 kg	<b>5797</b>
HCSBFX-48-S	1257 x 648 mm	1219 x 610 mm	1006, 1100, 1198	63 kg	<b>6482</b>

**NOTE:** Models are not a CE offering, items are sold as components for fabricator self certification.

\* Not available with CE Mark.

All Hot/Cold Shelf Built-In Flush Top with Unattached Control Box Only Models Feature:

Voltage: 220, 230 or 240 (CE not available).

Models Shipped with: Shelf assembly with temperature probes, solenoid valve (attached to shelf), Control Box (shipped loose), TXV valve (unattached).

**COUNTERTOP CUTOUT DIMENSIONS**

Model	Width		Depth	
	Minimum	Maximum	Minimum	Maximum
HCSBF(R)(X)-24-F	625 mm	635 mm	409 mm	419 mm
HCSBF(R)(X)-24-I	625 mm	635 mm	511 mm	521 mm
HCSBF(R)(X)-24-S	625 mm	635 mm	625 mm	635 mm
HCSBF(R)(X)-36-F	930 mm	940 mm	409 mm	419 mm
HCSBF(R)(X)-36-I	930 mm	940 mm	511 mm	521 mm
HCSBF(R)(X)-36-S	930 mm	940 mm	625 mm	635 mm
HCSBF(R)(X)-48-F	1234 mm	1245 mm	409 mm	419 mm
HCSBF(R)(X)-48-I	1234 mm	1245 mm	511 mm	521 mm
HCSBF(R)(X)-48-S	1234 mm	1245 mm	625 mm	635 mm
<b>Model</b>	<b>Width</b>		<b>Height</b>	
<b>Control Box</b>	372 mm		197 mm	

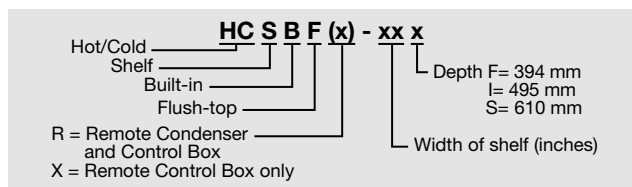

Built-Ins



## Glo-Ray® Heated Simulated Stone Built-In Rectangular Shelves

Match the heat zone to your countertops with Hatco's Glo-Ray Rectangular Heated Simulated Stone Shelves Built-In. These foodsafe shelves are ideal for buffet lines or hors d'oeuvre displays. These unique warmers will safely hold food hot while blending in with your décor.

- Shelves are made of approved foodsafe materials
- Features a lighted rocker switch and thermostatically-controlled heated base
- Includes remote Control Box with 915 mm conduit and 1829 mm cord and plug
- Models with simulated stone are Swanstone®



Standard Control Box



GRSSB-3618 in optional Bermuda Sand built into a simulated stone countertop

### GLO-RAY HEATED SIMULATED STONE BUILT-IN RECTANGULAR SHELVES

Model <sup>^</sup>	Dimensions W x D x H	Watts		Ship Weight	List Price <sup>‡</sup>
		220V-230V	230V-240V		
GRSSB-2418	651 x 498 x 57 mm	534-583	583-635	14 kg	<b>\$1647</b>
GRSSB-3018	803 x 498 x 57 mm	655-716	716-780	20 kg	<b>1714</b>
GRSSB-3618	956 x 498 x 57 mm	782-854	854-930	22 kg	<b>1785</b>
GRSSB-4818	1260 x 498 x 57 mm	1068-1166	1166-1270	23 kg	<b>1957</b>
GRSSB-6018	1565 x 498 x 57 mm	1310-1432	1432-1560	25 kg	<b>2562</b>
GRSSB-7218	1870 x 498 x 57 mm	1564-1708	1708-1860	32 kg	<b>2667</b>

<sup>‡</sup> Available with CE Mark, add \$20.

<sup>^</sup> Recommended for use in a metallic countertop. For other surfaces, verify that the material is suitable for temperatures up to 93°C.

All Glo-Ray Heated Simulated Stone Built-In Rectangular Shelf Models Feature:  
Cord location: Cord is attached to Control Box.

**NOTE:** For any size GRSSB, the next larger size GRA or GR2A Strip Heater will fit over the top. For example, a GRSSB-3018 will require a GRA-36 or GR2A-36. The GRA will have a tight fit to the frame of the base. The GR2A will have approximately a 102 mm space.

Be sure to check out our Hot/Cold and Cold only Built-In Shelves for a seamless look

### OPTIONS (available at time of purchase only)

Designer Color Bezel (Flush Mount Control Box, Bezel only) – Stainless steel Standard – Non-standard colors are non-returnable –

RED	Warm Red	GRAY	Gray Granite	NAVY	Navy Blue	COPPER	Antique Copper	<b>\$36</b>
BLACK	Black	WHITE	White Granite	GREEN	Hunter Green			

Simulated stone color – Non-standard colors are non-returnable – Night Sky Standard – No Charge

SS-GGRAN	Gray Granite	SS-BSAND	Bermuda Sand	SS-NSKY	Night Sky		
GRSSB-FLUSH-ITC	Flush Mount Electronic Control Box in stainless steel with Lighted Power Switch						<b>\$155</b>
GRSSB-FLUSH-TSTAT	Flush Mount Thermostatic Control Box in stainless steel with Lighted Power Switch						<b>No Charge</b>
COND-6	1829 mm Conduit in lieu of Standard 914 mm (used with Flush Mount ITC Control Box)						<b>\$34</b>
COND-10	3048 mm Conduit in lieu of Standard 914 mm (used with Flush Mount ITC Control Box)						<b>66</b>
GRSSB-REC	Built-In Heated Simulated Stone Shelf with Recessed Top						<b>No Charge</b>



GRSSB-FLUSH-ITC optional Flush Mount Recessed Electronic Control Box with lighted On/Off rocker switch and angled recessed controls



GRSSB-FLUSH-TSTAT optional Flush Mount Recessed Thermostatic Control Box with lighted On/Off rocker switch and angled recessed controls

### COLORS AND FINISHES – INSIDE BACK COVER

### HEATED SIMULATED STONE BUILT-IN RECTANGULAR SHELVES COUNTERTOP CUTOUT DIMENSIONS

Model	Minimum Width	Maximum Width	Minimum Depth	Maximum Depth
GRSSB-2418	625 mm	632 mm	473 mm	480 mm
GRSSB-3018	778 mm	784 mm	473 mm	480 mm
GRSSB-3618	930 mm	937 mm	473 mm	480 mm
GRSSB-4818	1235 mm	1241 mm	473 mm	480 mm
GRSSB-6018	1540 mm	1546 mm	473 mm	480 mm
GRSSB-7218	1845 mm	1851 mm	473 mm	480 mm

### OPTIONAL CONTROL BOX CUTOUT DIMENSIONS

Model	Width	Height	Depth
GRSSB-FLUSH-ITC	149 mm	174 mm	121 mm
GRSB-FLUSH-ITC			
GRSSB-FLUSH-TSTAT	149 mm	174 mm	102 mm
GRSB-FLUSH-TSTAT			

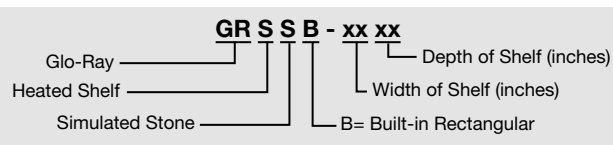



## Heated Base Glass Built-In Rectangular Shelves

Hatco Built-In Rectangular Heated Base Glass Shelves have a heated ceramic glass top to create uniform heat across the entire surface and are made of approved foodsafe materials. Adjustable thermostatic controls allow surface temperature to be controlled easily.

- Shelves are made of approved foodsafe materials
- Equipped with an attached stainless steel trim mounting ring (*Designer Black* or *White*)

- Lighted On/Off rocker switch
- Includes remote Control Box with 915 mm conduit and 1829 mm cord and plug



HBGBH-2418



HBGB-3618 in optional White Glass and Trim Ring



Standard Control Box

### HEATED BASE GLASS BUILT-IN RECTANGULAR SHELVES

Model <sup>^</sup>	Dimensions W x D x H	Watts		Ship Weight	List Price †
		220-230V	230-240V		
HBGB-2418	654 x 502 x 57 mm	420-459	459-500	15 kg	\$2309
HBGB-3018	806 x 502 x 57 mm	525-574	574-625	17 kg	2408
HBGB-3618	959 x 502 x 57 mm	630-689	689-750	18 kg	2509
HBGB-4818 ≈	1264 x 502 x 57 mm	840-918	918-1000	23 kg	2753
HBGB-6018 ≈	1568 x 502 x 57 mm	1050-1148	1148-1250	29 kg	2948
HBGB-7218 ≈	1873 x 502 x 57 mm	1260-1378	1378-1500	34 kg	3146

<sup>^</sup> Recommended for use in a metallic countertop. For other surfaces, verify material is suitable for temperatures up to 93°C.

† Available with CE Mark, no added charge.

≈ Units 1219 mm and larger are constructed of two equal size pieces of glass which create a seam.

#### All Heated Base Glass Built-In Rectangular Shelf Models Feature:

**Voltage:** 220, 240 single phase.

**Conduit:** 915 mm.

**Cord Location:** Cord is attached to Control Box.

### OPTIONS AND ACCESSORIES – PAGE 112

### HEATED BASE GLASS BUILT-IN RECTANGULAR HIGH-WATT SHELVES

Model <sup>^</sup>	Dimensions W x D x H	Volts	Watts	Ship Weight	List Price †
HBGBH-3018	806 x 502 x 57 mm	230	809	15 kg	2539
HBGBH-3618	959 x 502 x 57 mm	230	984	17 kg	2634
HBGBH-4818 ≈	1264 x 502 x 57 mm	230	1268	21 kg	2867
HBGBH-6018 ≈	1568 x 502 x 57 mm	230	1618	25 kg	3051
HBGBH-7218 ≈	1873 x 502 x 57 mm	230	1968	29 kg	3242

<sup>^</sup> Recommended for use in a metallic countertop. For other surfaces, verify that the material is suitable for temperatures up to 125°C.

† Available with CE Mark, no added charge.

≈ Units 1219 mm and larger are constructed of two equal sized pieces of glass which create a seam.

#### All Heated Base Glass Shelf Built-In Rectangular High-Watt Models Feature:

**Voltage:** 230 single phase.

**Conduit:** 1829 mm.

**Cord Location:** Cord is attached to Control Box.

**Plug:** Specify BS or Schuko.

### OPTIONS AND ACCESSORIES – PAGE 112



Standard HBGBH Flush Mount Recessed Electronic Control Box with lighted On/Off rocker switch and angled recessed controls

### HBGB AND HBGBH COUNTERTOP CUTOUT DIMENSIONS

Model	Min. Width	Max. Width	Min. Depth	Max. Depth
HBGB, HBGBH-2418	625 mm	632 mm	473 mm	480 mm
HBGB, HBGBH-3018	778 mm	784 mm	473 mm	480 mm
HBGB, HBGBH-3618	930 mm	937 mm	473 mm	480 mm
HBGB, HBGBH-4818	1235 mm	1241 mm	473 mm	480 mm
HBGB, HBGBH-6018	1540 mm	1546 mm	473 mm	480 mm
HBGB, HBGBH-7218	1845 mm	1851 mm	473 mm	480 mm

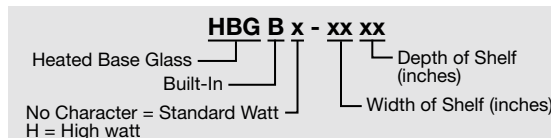



**HBGB-3618** below a **GR2AH-42** Strip Heater in optional *Designer Black* and Sneeze Guards

**OPTIONS** (available at time of purchase only)

**Ceramic Glass color (Black Standard)**

<b>HBGB-GLASS-WHT</b> White	<b>No Charge</b>
-----------------------------	------------------

**Color Bezel (Flush Mount Control Box, Bezel only) – Stainless steel Standard –**

*Non-standard colors are non-returnable –*

<b>HBGB-BEZEL-BLACK</b> Black	<b>\$ 36</b>
-------------------------------	--------------

<b>HBGB-BEZEL-WHITE</b> White	<b>36</b>
-------------------------------	-----------

**Trim Ring color – Stainless steel Standard – Non-standard colors are non-returnable –**

<b>HBGB-TRIM-BLK</b> <i>Designer Black</i>	<b>36</b>
--	-----------

<b>HBGB-TRIM-WHITE</b> White	<b>36</b>
------------------------------	-----------

<b>HBGBH-NO-TRIM</b> Unit without Trim Ring – HBGBH models only	<b>No Charge</b>
---	------------------

<b>HBGB-FLUSH-ITC</b> Flush Mount Electronic Control Box in stainless steel with lighted power switch – HBGB models only	<b>155</b>
--	------------

<b>HBGB-FLUSH-TSTAT</b> Flush Mount Thermostatic Control Box in stainless steel with lighted power switch – HBGB models only	<b>No Charge</b>
--	------------------

<b>COND-3</b> 915 mm conduit in lieu of Standard 1829 mm (used with Flush Mount ITC Control Box) – HBGBH models only	<b>\$36</b>
--	-------------

<b>COND-6</b> 1829 mm Conduit in lieu of Standard 915 mm (used with Flush Mount ITC Control Box) – HBGB models only	<b>34</b>
---	-----------

<b>COND-10</b> 3050 mm Conduit in lieu of Standard 915 mm (used with Flush Mount ITC Control Box)	<b>66</b>
---	-----------

<b>HBGB-REC</b> Built-in Heated Base Glass Shelf with Recessed Top – HBGB models only	<b>No Charge</b>
---	------------------



**HBGB-FLUSH-STAT**  
Optional Flush Mount Recessed *Thermostatic* Control Box with lighted On/Off rocker switch and angled recessed controls



**HBGB-FLUSH-ITC**  
Optional Flush Mount Recessed *Electronic* Control Box with lighted On/Off rocker switch and angled recessed controls

**CONTROL BOX CUTOUT DIMENSIONS**

Model	Width	Height	Depth
<b>HBGB-FLUSH-ITC</b>	149 mm	174 mm	121 mm
<b>HBGB-FLUSH-TSTAT</b>	149 mm	174 mm	102 mm





## Glo-Ray® Heated Shelves Built-In Rectangular with Recessed Top

Hatco's Glo-Ray Heated Shelves Built-In Rectangular with Recessed Top add heat to your serving surface. The 13 mm recessed top foodwarmer has a hardcoat aluminum surface and blanket-type element for uniform heat to extend food holding time.

- Uniform heat distribution with hardcoat aluminum surface and blanket-type element
- 914 mm flexible conduit channels power lines from the shelf to a control box
- Thermostatically-controlled heated base
- Standard controller includes infinite switch, lighted rocker switch and mounting brackets.



Standard Control Box

Be sure to check out our Hot/Cold and Cold only Built-In Shelves for a seamless look



GRSB-24-I

**NOTE:** For any size GRSB, the next larger size GRA or GR2A Strip Heater will fit over the top. For example, a GRSB-30 will require a GRA-36 or GR2A-36. The GRA will have a tight fit to the frame of the base. The GR2A will have approximately a 102 mm space.

### GLO-RAY HEATED SHELVES BUILT-IN RECTANGULAR WITH RECESSED TOP

Model <sup>^</sup>	Dimensions W x D x H	Cut-Out Dimensions		Watts		Ship Weight	List Price <sup>‡</sup>
		Min.-Max. Width	Min.-Max. Depth	220V <sup>*</sup>	240V <sup>*</sup>		
GRSB-24-F	648 x 432 x 73 mm	622-629 mm	406-413 mm	384	458	11 kg	\$1443
GRSB-24-I	648 x 533 x 73 mm	622-629 mm	508-514 mm	550	550	13 kg	1449
GRSB-24-O	648 x 800 x 73 mm	622-629 mm	775-781 mm	722	860	15 kg	1573
GRSB-30-F	800 x 432 x 73 mm	775-781 mm	406-413 mm	462	550	11 kg	1537
GRSB-30-I	800 x 533 x 73 mm	775-781 mm	508-514 mm	665	665	13 kg	1543
GRSB-30-O	800 x 800 x 73 mm	775-781 mm	775-781 mm	916	985	17 kg	1710
GRSB-36-F	953 x 432 x 73 mm	927-933 mm	406-413 mm	540	642	13 kg	1633
GRSB-36-I	953 x 533 x 73 mm	927-933 mm	508-514 mm	780	780	14 kg	1639
GRSB-36-O	953 x 800 x 73 mm	927-933 mm	775-781 mm	1110	1110	17 kg	1902
GRSB-42-F	1105 x 432 x 73 mm	1080-1086 mm	406-413 mm	627	746	14 kg	1713
GRSB-42-I	1105 x 533 x 73 mm	1080-1086 mm	508-514 mm	885	885	17 kg	1721
GRSB-42-O	1105 x 800 x 73 mm	1080-1086 mm	775-781 mm	1236	1305	21 kg	2087
GRSB-48-F	1257 x 432 x 73 mm	1232-1238 mm	406-413 mm	705	828	15 kg	1803
GRSB-48-I	1257 x 533 x 73 mm	1232-1238 mm	508-514 mm	1000	1000	18 kg	1809
GRSB-48-O	1257 x 800 x 73 mm	1232-1238 mm	775-781 mm	1430	1430	31 kg	2246
GRSB-54-I	1410 x 533 x 73 mm	1384-1391 mm	508-514 mm	1110	1110	18 kg	1900
GRSB-60-F	1562 x 432 x 73 mm	1537-1543 mm	406-413 mm	870	1034	18 kg	1987
GRSB-60-I	1562 x 533 x 73 mm	1537-1543 mm	508-514 mm	1220	1220	20 kg	1995
GRSB-60-O	1562 x 800 x 73 mm	1537-1543 mm	775-781 mm	1750	1750	29 kg	2608
GRSB-66-I	1715 x 533 x 73 mm	1689-1695 mm	508-514 mm	1330	1330	24 kg	2071
GRSB-72-F	1867 x 432 x 73 mm	1842-1848 mm	406-413 mm	1034	1230	20 kg	2146
GRSB-72-I	1867 x 533 x 73 mm	1842-1848 mm	508-514 mm	1440	1440	23 kg	2155
GRSB-72-O	1867 x 800 x 73 mm	1842-1848 mm	775-781 mm	2070	2070	31 kg	2973

\* Single Phase

<sup>^</sup> Recommended for use in a metallic countertop. For other surfaces, verify that the material is suitable for temperatures up to 93°C.

<sup>‡</sup> Available with CE Mark, no added charge, except models GRSB-24-O, -30-O and -42-O.

All Glo-Ray Heated Shelf Built-In Rectangular with Recessed Top Models Feature:

Voltage: 220 or 240 single phase.

Usable Heated Shelf Space: Width of unit minus 38 mm x depth of unit minus 38 mm.

Cord Location: Cord is attached to Control Box.

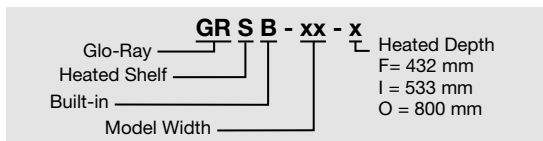

### OPTIONS (available at time of purchase only)

Designer Color Bezel (Flush Mount Control Box, Bezel only) – Stainless steel Standard –

Non-standard colors are non-returnable –

\$36

RED Warm Red GRAY Gray Granite NAVY Navy Blue COPPER Antique Copper

BLACK Black WHITE White Granite GREEN Hunter Green

GRSB-FLUSH-ITC Flush Mount Electronic Control Box in stainless steel with lighted power switch (not available with CE Mark)\*

\$155

GRSB-FLUSH-TSTAT Flush Mount Thermostatic Control Box in stainless steel with lighted power switch\*

No Charge

COND-6 1829 mm Conduit in lieu of Standard 914 mm (used with Flush Mount ITC Control Box)

\$34

COND-10 3048 mm Conduit in lieu of Standard 914 mm (used with Flush Mount ITC Control Box)

66

\* See page 110 for Control Box cutout dimensions.

FOOD PANS AND TRIVETS – PAGE 178  
COLORS AND FINISHES – INSIDE BACK COVER

GRSB-FLUSH-ITC optional Flush Mount Recessed Electronic Control Box with lighted On/Off rocker switch and angled recessed controls



GRSB-FLUSH-TSTAT optional Flush Mount Recessed Thermostatic Control Box with lighted On/Off rocker switch and angled recessed controls





## Glo-Ray® Heated Shelf Built-In Rectangular with Flush Top

Let Hatco add heat to your serving surface with this terrific shelf. This flush top foodwarmer has a hardcoat aluminum surface and blanket-type element for uniform heat to extend your food holding time.

- Uniform heat distribution with hardcoat aluminum surface and blanket-type element
- 914 mm flexible conduit channels power lines from the shelf to a control box
- Standard controller includes control thermostat, an illuminated power switch and mounting brackets

- Thermostatically-controlled heated base
- Model widths from: 648 to 1867 mm
- Optional stainless steel surface



**GRSBF-60-0** built into a simulated stone countertop with accessory pans, shown below a **GR2AL-96D** Strip Heater in *Designer Color* with optional Sneeze Guards

**NOTE:** For any size GRSBF, the next larger size GRA or GR2A Strip Heater will fit over the top. For example, a GRSBF-30 will require a GRA-36 or GR2A-36. The GRA will have a tight fit to the frame of the base. The GR2A will have approximately a 102 mm space.

### GLO-RAY HEATED SHELVES BUILT-IN RECTANGULAR WITH FLUSH TOP

Model <sup>^</sup>	Dimensions W x D x H	Cut-Out Dimensions		Watts		Ship Weight	List Price <sup>‡</sup>
		Min.-Max. Width	Min.-Max. Depth	220V <sup>*</sup>	240V <sup>*</sup>		
GRSBF-24-F	648 x 432 x 57 mm	622-629 mm	406-413 mm	384	458	13 kg	<b>\$1443</b>
GRSBF-24-I	648 x 533 x 57 mm	622-629 mm	508-514 mm	550	550	12 kg	<b>1449</b>
GRSBF-24-S	648 x 648 x 57 mm	622-629 mm	622-629 mm	640	762	15 kg	<b>1534</b>
GRSBF-24-O	648 x 800 x 57 mm	622-629 mm	775-781 mm	722	860	16 kg	<b>1573</b>
GRSBF-30-F	800 x 432 x 57 mm	775-781 mm	406-413 mm	462	550	11 kg	<b>1537</b>
GRSBF-30-I	800 x 533 x 57 mm	775-781 mm	508-514 mm	665	665	14 kg	<b>1543</b>
GRSBF-30-S	800 x 648 x 57 mm	775-781 mm	622-629 mm	755	898	15 kg	<b>1661</b>
GRSBF-30-O	800 x 800 x 57 mm	775-781 mm	775-781 mm	916	985	17 kg	<b>1710</b>
GRSBF-36-F	953 x 432 x 57 mm	927-933 mm	406-413 mm	540	642	15 kg	<b>1633</b>
GRSBF-36-I	953 x 533 x 57 mm	927-933 mm	508-514 mm	780	780	14 kg	<b>1639</b>
GRSBF-36-S	953 x 648 x 57 mm	927-933 mm	622-629 mm	870	1034	16 kg	<b>1846</b>
GRSBF-36-O	953 x 800 x 57 mm	927-933 mm	775-781 mm	1110	1110	17 kg	<b>1902</b>
GRSBF-42-F	1105 x 432 x 57 mm	1080-1086 mm	406-413 mm	627	746	17 kg	<b>1713</b>
GRSBF-42-I	1105 x 533 x 57 mm	1080-1086 mm	508-514 mm	885	885	15 kg	<b>1721</b>
GRSBF-42-S	1105 x 648 x 57 mm	1080-1086 mm	622-629 mm	1006	1198	18 kg	<b>2021</b>
GRSBF-42-O	1105 x 800 x 57 mm	1080-1086 mm	775-781 mm	1236	1305	22 kg	<b>2087</b>
GRSBF-48-F	1257 x 432 x 57 mm	1232-1238 mm	406-413 mm	705	828	16 kg	<b>1803</b>
GRSBF-48-I	1257 x 533 x 57 mm	1232-1238 mm	508-514 mm	1000	1000	18 kg	<b>1809</b>
GRSBF-48-S	1257 x 648 x 57 mm	1232-1238 mm	622-629 mm	1121	1334	19 kg	<b>2172</b>
GRSBF-48-O	1257 x 800 x 57 mm	1232-1238 mm	775-781 mm	1430	1430	22 kg	<b>2246</b>
GRSBF-54-I	1409 x 533 x 57 mm	1384-1391 mm	508-514 mm	1110	1110	19 kg	<b>1902</b>
GRSBF-60-F	1562 x 432 x 57 mm	1537-1543 mm	406-413 mm	870	1034	19 kg	<b>1987</b>
GRSBF-60-I	1562 x 533 x 57 mm	1537-1543 mm	508-514 mm	1220	1220	22 kg	<b>1995</b>
GRSBF-60-S	1562 x 648 x 57 mm	1537-1543 mm	622-629 mm	1372	1634	25 kg	<b>2538</b>
GRSBF-60-O	1562 x 800 x 57 mm	1537-1543 mm	775-781 mm	1750	1750	29 kg	<b>2608</b>
GRSBF-66-I	1715 x 533 x 57 mm	1689-1695 mm	508-514 mm	1330	1330	23 kg	<b>2075</b>
GRSBF-72-F	1867 x 432 x 57 mm	1842-1848 mm	406-413 mm	1034	1230	20 kg	<b>2146</b>
GRSBF-72-I	1867 x 533 x 57 mm	1842-1848 mm	508-514 mm	1440	1440	24 kg	<b>2155</b>
GRSBF-72-S	1867 x 648 x 57 mm	1842-1848 mm	622-629 mm	1602	1906	27 kg	<b>2856</b>
GRSBF-72-O	1867 x 800 x 57 mm	1842-1848 mm	775-781 mm	2070	2070	31 kg	<b>2973</b>

<sup>\*</sup>Single Phase

<sup>^</sup> Recommended for use in metallic countertop, for other surfaces, verify material is suitable for temperatures up to 93°C.

<sup>‡</sup> Available with CE Mark, no added charge, except models GRSBF-24-0, -30-0 and -42-0.

All Glo-Ray Heated Shelf Built-In Rectangular with Flush Top Models Feature:

Usable Heated Shelf Space: Entire surface. Cord Location: Cord is attached to Control Box.

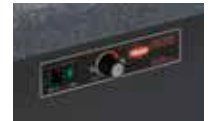

Standard Control Box

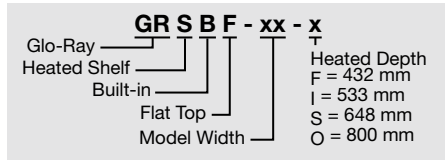

### OPTIONS (available at time of purchase only)

**Designer Color Bezel (Flush Mount Control Box, Bezel only) – Stainless steel Standard – Non-standard colors are non-returnable –**

RED Warm Red	GRAY Gray Granite	NAVY Navy Blue	COPPER Antique Copper	<b>\$36</b>
BLACK Black	WHITE White Granite	GREEN Hunter Green		
GRSBF-SS	Stainless steel surface in lieu of hardcoated (GRSBF models only)			<b>No Charge</b>
GRSB-FLUSH-ITC	Flush Mount Electronic Control Box in stainless steel with lighted power switch (not available with CE Mark)*			<b>\$155</b>
GRSB-FLUSH-TSTAT	Flush Mount Thermostatic Control Box in stainless steel with lighted power switch*			<b>No Charge</b>
COND-6	1829 mm Conduit in lieu of Standard 914 mm (used with Flush Mount ITC Control Box)			<b>\$34</b>
COND-10	3048 mm Conduit in lieu of Standard 914 mm (used with Flush Mount ITC Control Box)			<b>66</b>

\* See page 110 for Control Box cutout dimensions.

**GRSB-FLUSH-ITC**  
optional Flush Mount Recessed *Electronic* Control Box with lighted On/Off rocker switch and angled recessed controls



**GRSB-FLUSH-TSTAT**  
optional Flush Mount Recessed *Thermostatic* Control Box with lighted On/Off rocker switch and angled recessed controls



# Drawer Warmers

*Cafeterias • Convenience Stores  
Restaurants & Cafés • Clubs & Bars • Concessions*



**CDW-3N** *pg. 116*



**HDW-2** with 152 mm deep Food Pans *pg. 117*



**HDW-2** with new optional Touchscreen Control *pg. 117*



**HDW-1N** with Digital Temperature Control *pg. 117*



**HDW-1.5R2** with optional Touch Screen Control *pg. 117*



**HDW-2B** in optional *Designer Warm Red* *pg. 118*



## Convected Drawer Warmer

This drawer warmer is designed to keep a variety of food products hot and flavor-fresh until served. With a single non-humidified cavity and a single electronic temperature control, this unit provides even, dry heat for food products that do not require humidity. With insulated top, sides and back, they provide excellent energy efficiency.

- Digital electronic controller for easy programming
- Low velocity convected air system provides even temperature throughout the cabinet
- Tough, solid chrome handles are angled to avoid contact from passing carts
- Narrow width fits most kitchen footprints
- Heavy-duty drawer slides with nylon rollers
- Includes three full-size pans
- Provides even, dry heat for food products that do not require humidity.



CDW-3N

### CONVECTED DRAWER WARMER

Model	Dimensions W x D* x H	Voltage Single Phase	Watts	Ship Weight	List Price <sup>‡</sup>
CDW-3N	421 x 774 x 762 mm	230	933	81 kg	\$4326

<sup>‡</sup> Available with CE Mark, at no added charge.

\*Includes 32 mm for drawer handle.

#### All Convected Models Feature:

**Voltage:** 230, single phase.

**Models Shipped with:** One 152 mm deep food pan per drawer, low profile 51 mm casters, 1829 mm cord and plug.

**Cord Location:** Back of unit, top right corner.

### FOOD PANS AND TRIVETS – PAGE 178

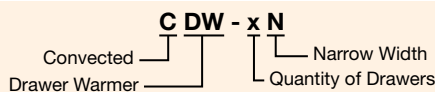



## Freestanding Drawer Warmers

Hold everything from meat to vegetables to rolls in the Hatco Drawer Warmers. Built for tough kitchen duty with rugged construction and heavy-duty hardware, these warmers keep a variety of foods hot and fresh until served.

- Standard and narrow widths
- 1-, 2-, 3- or 4-drawer freestanding models
- Completely insulated individual cavities provide maximum energy efficiency (excludes HDW-1R2, -2R2)
- 12-gauge stainless steel heavy-duty drawer slides with nylon rollers
- Each drawer has a recessed individual thermostatic control, temperature monitor, vent slides and power switch
- Standard width Drawer Warmer pans lift straight out of drawer (Narrow and Split models require slight tilting of pan)
- Each drawer of the HDW-1R2, 1.5R2, -2R2 will accommodate one half-size sheet pan

**HDW-2** with new optional Touchscreen Control and Accessory 152 mm stainless steel legs



Drawer Temperature    Temperature Adjustment    Drawer Timer



**HDW-2N**



**HDW-1.5R2** with optional touchscreen control



**HDW-1R2**



**HDW-2R2**

### FREESTANDING DRAWER WARMERS

Model	Dimensions* W x D x H	Voltage Single Phase	Watts	Ship Weight Includes weight of pans	List Price*	
					w/pans	w/o pans
<b>Standard</b>						
<b>HDW-1</b>	749 x 575 x 279 mm	220, 240	450	44 kg	<b>\$2326</b>	<b>\$2276</b>
<b>HDW-2</b>	749 x 575 x 537 mm	220, 240	900	76 kg	<b>3921</b>	<b>3821</b>
<b>HDW-3</b>	749 x 575 x 794 mm	220, 240	1350	105 kg	<b>5520</b>	<b>5370</b>
<b>HDW-4</b>	749 x 575 x 1051 mm	220, 240	1800	135 kg	<b>7274</b>	<b>7074</b>
<b>Narrow</b>						
<b>HDW-1N</b>	530 x 686 x 279 mm	220, 240	450	38 kg	<b>2326</b>	<b>2276</b>
<b>HDW-2N</b>	530 x 686 x 537 mm	220, 240	900	76 kg	<b>3921</b>	<b>3821</b>
<b>HDW-3N</b>	530 x 686 x 794 mm	220, 240	1350	105 kg	<b>5520</b>	<b>5370</b>

\* 220V, 240V available with CE Mark. Add \$40 for one drawer, \$70 for two drawer, \$100 for three drawer, \$130 for four drawer models.

Not available with optional digital temperature control.

\* Add 32 mm to depth for drawer handle. Height does not include legs/casters.

#### All Freestanding Drawer Warmer Models Feature:

Models w/Pans Shipped with: One 152 mm deep food pan per drawer.

HDW-1, -2 and -3 and all Narrow Models Shipped with: 102 mm plastic legs, 1829 mm cord and plug.

HDW-4 Shipped with: 152 mm stainless steel legs, 1829 mm cord and plug.

Cord Location: Back of unit, lower left corner.

### SPLIT DRAWER WARMERS

Model	Dimensions* W x D x H	Voltage Single Phase	Watts	Ship Weight Includes weight of pans	List Price*	
					w/pans	w/o pans
<b>HDW-1R2</b>	746 x 419 x 378 mm	230	634	41 kg	<b>\$ 3338</b>	<b>\$ 3288</b>
<b>HDW-1.5R2</b>	733 x 419 x 494 mm	230	909	53 kg	<b>4739</b>	<b>4617</b>
<b>HDW-2R2</b>	746 x 419 x 610 mm	230	1185	61 kg	<b>5203</b>	<b>5103</b>

\* Add 32 mm to depth for drawer handle. Height includes legs.

\* 230V available with CE Mark. Add \$40 for one drawer, \$70 for two drawer models.

#### All Split Drawer Warmer Models Feature:

Plug: BS-1363, 7/7 Schuko, AS-3112.

HDW-1R2 shipped with pans: Two 527 x 324 x 64 mm food pans, 102 mm legs, 1829 mm cord and plug.

HDW-1.5R2 shipped with pans: Three 527 x 324 x 64 mm food pans, 102 mm legs, 1829 mm cord and plug.

HDW-2R2 shipped with pans: Four 527 x 324 x 64 mm food pans, 102 mm legs, 1829 mm cord and plug.

Pan Capacity: 527 x 324 x 64 mm.

Cord Location: Back of unit, lower left corner.

### OPTIONS AND ACCESSORIES – PAGE 119

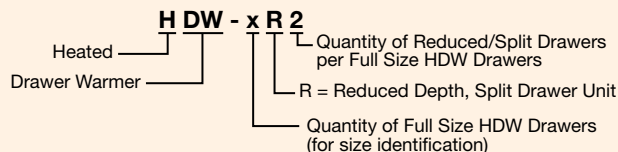
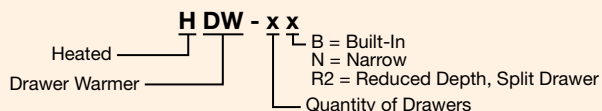



## Built-In Drawer Warmers

Hold everything from meat to vegetables to rolls in Hatco Drawer Warmers. Built for tough kitchen duty with rugged construction and heavy-duty hardware, these warmers keep a variety of foods hot and fresh until served.

- Standard and narrow widths
- 1-, 2- or 3-drawer built-in models
- Completely insulated individual cavities provide maximum energy efficiency
- 12-gauge stainless steel heavy-duty drawer slides with nylon rollers
- Each drawer has a recessed individual thermostatic control, temperature monitor, vent slides and power switch
- Standard width Drawer Warmer pans lift straight out of drawer (HDW-1BN, -2BN and -3BN models require tipping the pan to install)



HDW-3B



HDW-2B

### BUILT-IN DRAWER WARMERS

Model	Dimensions* W x D x H	Voltage Single Phase	Watts	Ship Weight Includes weight of pans	List Price*	
					w/pans	w/o pans
<b>Standard</b>						
HDW-1B	715 x 568 x 248 mm	220, 240	450	40 kg	\$2239	\$2189
HDW-2B	715 x 568 x 506 mm	220, 240	900	72 kg	3758	3658
HDW-3B	715 x 568 x 763 mm	220, 240	1350	105 kg	5274	5124
<b>Narrow</b>						
HDW-1BN	494 x 679 x 248 mm	220, 240	450	40 kg	2239	2189
HDW-2BN	494 x 679 x 506 mm	220, 240	900	72 kg	3758	3658
HDW-3BN	494 x 679 x 763 mm	220, 240	1350	101 kg	5274	5124

\* Available with CE Mark. Add \$40 for one drawer, \$70 for two drawer, \$100 for three drawer models.

\* Add 32 mm to depth for drawer handle. Width and Height excludes front mounting flange.

#### All Built-In Drawer Warmer Models Feature:

Voltage: 220 or 240.

Models w/Pans Shipped with: One 152 mm deep food pan per drawer, and 1219 mm flexible conduit.

### OPTIONS AND ACCESSORIES – PAGE 119

#### BUILT-IN CUTOUT REQUIREMENTS

Model	Width	Depth*	Height
HDW-1B	720 mm	610 mm	257 mm
HDW-2B	720 mm	610 mm	514 mm
HDW-3B	720 mm	610 mm	771 mm
HDW-1BN	500 mm	720 mm	257 mm
HDW-2BN	500 mm	720 mm	514 mm
HDW-3BN	500 mm	720 mm	771 mm

\*Depth includes 38 mm for conduit connector.

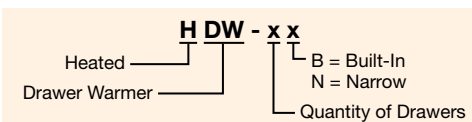

**OPTIONS** (available at time of purchase only)

**Designer Drawer Front colors per drawer (not available for HDW-1R2, -1.5R2, -2R2 models)**  
**Non-standard colors are non-returnable – stainless steel Standard**

<b>RED</b>	Warm Red	<b>\$59</b>
<b>BLACK</b>	Black	<b>59</b>
<b>GRAY</b>	Gray Granite	<b>59</b>
<b>WHITE</b>	White Granite	<b>59</b>
<b>NAVY</b>	Navy Blue	<b>59</b>
<b>GREEN</b>	Hunter Green	<b>59</b>
<b>COPPER</b>	Antique Copper	<b>59</b>
<b>HDW-TTC</b>	Temperature Control Timer – 6-channel control touchscreen display	<b>534</b>
<b>OS-PAN</b>	Oversized Drawer Frame and Pan – 508 x 381 x 127 mm – in lieu of Standard Drawer with Pan (Standard width models only)	<b>per drawer 122</b>
<b>BIS DRAWER</b>	Biscuit Pan Drawer accommodates two 457 x 330 mm Half-Size Sheet Pans (not included) in lieu of Standard Drawer with Pan (Standard width models only)	<b>No Charge</b>
<b>HDW-CHIP</b>	Chip Guard	<b>per drawer 41</b>
<b>RD-NOVENT</b>	No drawer vents (HDW-1R2, -1.5R2, -2R2 only)	<b>No Charge</b>



**ACCESSORIES** (available for purchase at any time)

<b>HDW-TRIVET</b>	Custom Trivet 445 x 242 x 13 mm, raises food product 13 mm off bottom of full-size pan	<b>\$ 50</b>
<b>HDW 6" LEG</b>	152 mm Adjustable Stainless Steel Legs (Standard on HDW-4) (excludes HDW-1R2, -1.5R2, -2R2)	<b>166</b>
<b>HDW-CASTER-2</b>	51 mm diameter casters – all swivel, 2 lock – adds 57 mm to height of unit, HDW-1, -2, -3 models only (excludes HDW-1R2, -1.5R2, -2R2)	<b>205</b>
<b>HDW-CASTER-3</b>	76 mm diameter Locking Casters – all swivel, all lock – adds 108 mm to height of unit, HDW-1, -2, -3 models only (excludes HDW-1R2, -1.5R2, -2R2)	<b>205</b>
<b>HDW-CASTER-5</b>	127 mm diameter Locking Casters – all swivel, all lock – adds 159 mm to height of unit (Excludes HDW-1R2, -1.5R2, -2R2)	<b>243</b>
<b>HDW-SPILL</b>	Water/Spillage Pan – one per drawer (excludes HDW-1R2, -1.5R2, -2R2 and BIS Drawer and OS-Pan Options)	<b>231</b>
<b>HDW-SPLASH</b>	Splash Baffle – one per drawer (excludes HDW-1R2, -1.5R2, -2R2 and BIS Drawer and OS-Pan Options)	<b>46</b>

**FOOD PANS AND TRIVETS – PAGE 178**  
**COLORS AND FINISHES – INSIDE BACK COVER**

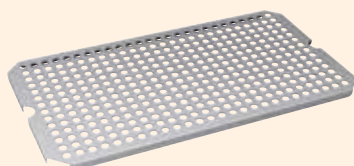

**HDW-TRIVET** Accessory



**Casters - Accessory**  
**HDW-CASTER-2** all swivel, 2 lock  
**HDW-CASTER-3** all swivel, all lock  
**HDW-CASTER-5** all swivel, all lock



**HDW 6" LEG** Accessory



**HDW-SPLASH** Accessory

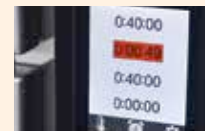

**HDW-TTC option**  
 Shown: Temperature adjustment and timer touchscreen control (TTC)



Biscuit Pan Drawer (pans not included)  
**BIS DRAWER** option

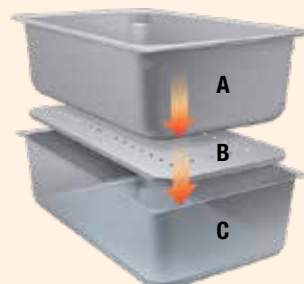

**Additional Humidity**  
 A. Stainless Steel Food Pan  
 B. Splash Baffle  
**HDW-SPLASH** Accessory  
 C. Water/Spillage Pan – add 6 mm of water, **HDW-SPILL** Accessory

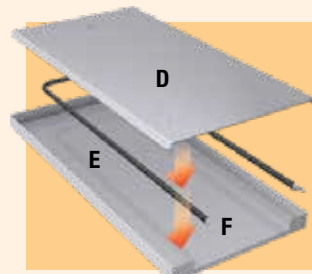

**Prevents chips from reaching the element**  
 D. Heat Shield (included)  
 E. Heating Element (included)  
 F. Chip Guard **HDW-CHIP** option (Standard width shown)



# Merchandisers

*Cafeterias • Convenience Stores  
Supermarkets & Delis • Restaurants & Cafés  
Clubs & Bars • Catering • Concessions*



**GRPWS-4824T** with base heat only (signs not included) *pg. 121*



**GRSDS-36D** Dual slant shelf *pg. 123*



**GR2SDS-48D** with standard *Designer Black* inset panels and corner caps *pg. 125*



**GRCMW-1** and **GRCMW-1D** in optional *Bermuda Sand Simulated Stone* color *pg. 130*



**GRCD-2PD** in optional *Designer Warm Red* with flip-up doors *pg. 131*



**GRHD-4PD** with optional double side opening and accessory food pans *pg.133*



## Glo-Ray® Pizza Warmers

Convenient for self-serve and quick-serve areas. The Hatco Glo-Ray® Pizza Warmers with base heat only hold boxed or bagged pizzas. Available in three shelf configurations to showcase food in an easy pass-through display.

- Box stop doubles as the sign holder, a standard feature (signs not included)
- Ideal for holding boxed products for high volume applications like stadiums, schools, convenience stores and amusement parks
- Constructed of aluminum and stainless steel with tempered glass side panels
- Separate power switch for each thermostatically-controlled shelf
- Incandescent lights with bright annealed reflectors illuminate the holding areas



GRPWS-2424T in optional Designer Black



GRPWS-4824T with base heat only (signs not included)

Merchandisers

### SLANT DISPLAY WARMERS – TRIPLE SHELF

Model	No. of Bulbs	Dimensions W x D x H (Height includes legs)	Usable Heated Shelf Space W x D	Voltage single phase	Watts	Ship Weight	List Price <sup>‡</sup>
GRPWS-2424T	6	607 x 663 x 781 mm	573 x 605 mm	220, 240	1276-1518	53 kg	\$4775
GRPWS-3624T	9	911 x 663 x 781 mm	877 x 605 mm	220, 240	1800-2143	76 kg	5675
GRPWS-4824T	12	1216 x 663 x 781 mm	1182 x 605 mm	220, 240	2301-2738	103 kg	6414

‡ CE Mark not available.

All Slant Models Feature:

Cord Location: Server side, bottom right corner.

### OPTIONS (available at time of purchase only)

Designer Colors – Non-standard colors are non-returnable – Stainless Steel Standard –

RED	Warm Red	\$360
BLACK	Black	360
GRAY	Gray Granite	360
WHITE	White Granite	360
NAVY	Navy Blue	360
GREEN	Hunter Green	360
COPPER	Antique Copper	360

### COLORS AND FINISHES – INSIDE BACK COVER

### RECOMMENDED SIGN DIMENSIONS

Model

GRPWS-2424T: 565 x 60 x 3 mm

GRPWS-3624T: 870 x 60 x 3 mm

GRPWS-4824T: 1175 x 60 x 3 mm

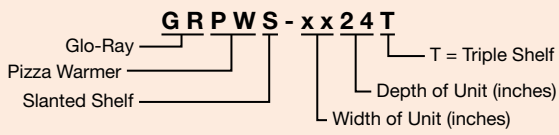
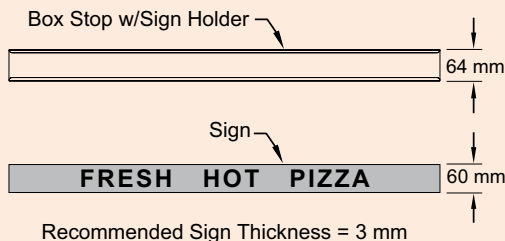

## Glo-Ray® Merchandising Warmers

Designed with both a slanted and horizontal shelf, Glo-Ray® Merchandising Warmers offer the convenience of customer self-serve with the efficiency of preparing and holding product in advance for peak serving periods.

- Warmer includes a slant and horizontal shelf for merchandising a variety of products like popcorn on the top shelf and nachos, boxed pizza or wrapped food on the bottom
- Standard Indicating Temperature Control (ITC) enhances accuracy and provides digital readout of temperatures
- Thermostatically-controlled hardcoated heated base to extend holding times
- Pre-focused infrared top heat directs heat to the outer edges where heat loss is greatest
- Product divider rods and 102 mm legs included
- Shatter-resistant incandescent lights illuminate the holding areas and emphasize the product



**GRSDS/H-36D** with slant and horizontal shelf and optional 381 mm clearance top shelf

### SLANT/HORIZONTAL DISPLAY WARMERS – DUAL SHELVES

Model	No. of Bulbs, Divider Rods	Dimensions W x D x H	Voltage single phase	Watts	Ship Weight	List Price <sup>‡</sup>
<b>GRSDS/H-36D</b>	4, 14	914 x 616 x 851 mm	220, 240	1669-1900	54 kg	<b>\$5764</b>
<b>GRSDS/H-41D</b>	6, 16	1041 x 616 x 851 mm	220, 240	1951-2325	62 kg	<b>6163</b>

<sup>‡</sup> Available with CE Mark, at no added charge.

**All Slant/Horizontal Shelf Models Feature:**

Cord Location: Server side, bottom right corner.

### OPTIONS (available at time of purchase only)

**Designer Colors – Non-standard colors are non-returnable – Glossy Gray Standard –**

<b>RED</b>	Warm Red	<b>\$360</b>
<b>BLACK</b>	Black	<b>360</b>
<b>GRAY</b>	Gray Granite	<b>360</b>
<b>WHITE</b>	White Granite	<b>360</b>
<b>NAVY</b>	Navy Blue	<b>360</b>
<b>GREEN</b>	Hunter Green	<b>360</b>
<b>COPPER</b>	Antique Copper	<b>360</b>
<b>15SPACE</b>	381 mm clearance for top shelf in lieu of standard 305 mm (add 76 mm to height of unit)	<b>\$105</b>

### ACCESSORIES (available for purchase at any time)

<b>GRSDS-DIV</b>	Additional Stainless Steel Divider Rods (Bottom shelf only)	<b>each \$21</b>
<b>GRSDH-DIV</b>	Additional Stainless Steel Divider Rods (Top shelf only)	<b>each 21</b>

### COLORS AND FINISHES – INSIDE BACK COVER

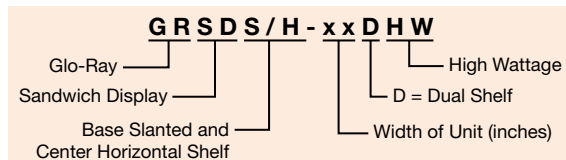



## Glo-Ray® Merchandising Warmers

Designed specifically for showcasing wrapped or boxed product, the Hatco Glo-Ray® Merchandising Warmers hold hot food safely at proper serving temperatures. These warmers offer the convenience of self-serve and the efficiency of kitchen-to-server holding.

- Available in single- or two-tier models
- Horizontal or slant shelves
- Product divider rods sort food displays
- Thermostatically-controlled hardcoated heated base, with a temperature range of 85°- 93°C, to extend holding times
- Pre-focused infrared top heat directs heat to the outer edges where heat loss is greatest
- Shatter-resistant incandescent lights illuminate the holding areas and emphasize the product



**GRSDS-30**  
with accessory  
102 mm legs



**GRSDH-30D**

Merchandisers

### HORIZONTAL MERCHANDISING WARMERS

Model	No. of Bulbs, Divider Rods	Dimensions W x D x H (Height includes legs)	Usable Heated Shelf Space (W x D)	Voltage	Watts	Ship Weight	List Price*
<b>Single Shelf</b>							
GRSDH-24	2, 5	610 x 495 x 303 mm	577 x 419 mm	220, 240V	724-861	22 kg	<b>\$2401</b>
GRSDH-30	2, 6	762 x 495 x 303 mm	730 x 419 mm	220, 240V	890-1060	25 kg	<b>2658</b>
GRSDH-36	2, 7	914 x 495 x 303 mm	882 x 419 mm	220, 240V	1074-1278	30 kg	<b>2876</b>
GRSDH-41	3, 8	1041 x 495 x 379 mm	1009 x 419 mm	220, 240V	1228-1464	34 kg	<b>3128</b>
GRSDH-52	4, 10	1321 x 495 x 379 mm	1289 x 419 mm	220, 240V	1604-1912	39 kg	<b>3645</b>
GRSDH-60	5, 12	1524 x 495 x 379 mm	1492 x 419 mm	220, 240V	1830-2180	60 kg	<b>4102</b>
<b>Dual Shelf</b>							
GRSDH-24D	4, 10	610 x 495 x 303 mm	577 x 419 mm	220, 240V	1448-1722	40 kg	<b>\$4211</b>
GRSDH-30D	4, 12	762 x 495 x 643 mm	730 x 419 mm	220, 240V	1780-2120	45 kg	<b>4408</b>
GRSDH-36D	4, 14	914 x 495 x 643 mm	882 x 419 mm	220, 240V	2148-2556	54 kg	<b>4664</b>
GRSDH-41D	6, 16	1041 x 495 x 643 mm	1009 x 419 mm	220, 240V	2456-2928	62 kg	<b>4953</b>
GRSDH-52D*	8, 20	1321 x 495 x 643 mm	1289 x 419 mm	220, 240V	3208-3824	78 kg	<b>5701</b>
GRSDH-60D	10, 24	1524 x 495 x 643 mm	1492 x 419 mm	220, 240V	3660-4360	89 kg	<b>6279</b>

### SLANT MERCHANDISING WARMERS

Model	No. of Bulbs, Divider Rods	Dimensions W x D x H (Height includes legs)	Usable Heated Shelf Space (W x D)	Voltage	Watts	Ship Weight	List Price*
<b>Single Shelf</b>							
GRSDS-24	2, 5	610 x 616 x 469 mm	572 x 533 mm	220, 240V	629-749	36 kg	<b>\$2928</b>
GRSDS-30	2, 6	762 x 616 x 469 mm	724 x 533 mm	220, 240V	730-870	36 kg	<b>3137</b>
GRSDS-36	2, 7	914 x 616 x 545 mm	876 x 533 mm	220, 240V	864-1030	42 kg	<b>3374</b>
GRSDS-41	3, 8	1041 x 616 x 545 mm	1003 x 533 mm	220, 240V	1003-1195	44 kg	<b>3620</b>
GRSDS-52	4, 10	1321 x 616 x 545 mm	1283 x 533 mm	220, 240V	1275-1520	50 kg	<b>4147</b>
GRSDS-60	5, 12	1524 x 616 x 545 mm	1486 x 533 mm	220, 240V	1665-1715	76 kg	<b>4477</b>
<b>Dual Shelf</b>							
GRSDS-24D	4, 10	610 x 616 x 820 mm	572 x 533 mm	220, 240V	1260-1502	52 kg	<b>\$4553</b>
GRSDS-30D	4, 12	762 x 616 x 820 mm	724 x 533 mm	220, 240V	1419-1690	64 kg	<b>4829</b>
GRSDS-36D	4, 14	914 x 616 x 820 mm	876 x 533 mm	220, 240V	1669-1990	73 kg	<b>5142</b>
GRSDS-41D	6, 16	1041 x 616 x 820 mm	1003 x 533 mm	220, 240V	1951-2325	82 kg	<b>5526</b>
GRSDS-52D	8, 20	1321 x 616 x 820 mm	1283 x 533 mm	220, 240V	2483-2960	98 kg	<b>6413</b>
GRSDS-60D*	10, 24	1524 x 616 x 820 mm	1486 x 533 mm	220, 240V	3240-3340	108 kg	<b>6809</b>

\* Available with CE Mark, at no added charge.

\* Cord without plug on 240V.

#### All Merchandising Warmer Models Feature:

Cord Location: GRSDH Models: Server side, bottom left corner.

GRSDS Models: Server side bottom right corner.

#### OPTIONS AND ACCESSORIES – PAGE 124

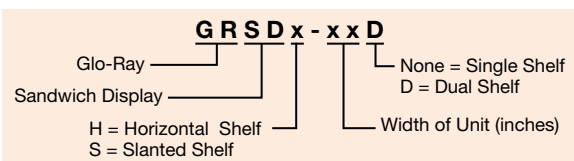



Two GRSDH-36D with dual horizontal shelves

**OPTIONS** (available at time of purchase only)

ITC-S	Indicating Temperature Control (LED) for single shelf	\$263
ITC-D	Indicating Temperature Control (LED) for dual shelf	453
SSEND	Stainless Steel End Panels in lieu of Glass End Panels	per shelf 36
<b>Sneeze Guard 127 mm on Customer side (GRSDS one side GRSDH two sides) –</b>		
GRSD24BP	610 mm wide models	per shelf \$120
GRSD30BP	762 mm wide models	per shelf 142
GRSD36BP	914 mm wide models	per shelf 166
GRSD41BP	1041 mm wide models	per shelf 190
GRSD52BP	1321 mm wide models	per shelf 217
GRSD60BP	1524 mm wide models	per shelf 307
GRSDFLIPLOCK1	Flip-Up Door Locking Plate for GRSDS-xx, -xxD models 24 to 41	per shelf \$14
GRSDFLIPLOCK2	Flip-Up Door Locking Plates for GRSDS-xx, -xxD models 52 to 60	per shelf 34
<b>Display Sign Holder (Signs not included) – Color matches unit color – Top or intermediate Shelf –</b>		
GRSDS-24SIGN	610 mm width. Requires 575 W x 100 H x 2 D mm Sign	each \$70
GRSDS-30SIGN	762 mm width. Requires 727 W x 100 H x 2 D mm Sign	each 70
GRSDS-36SIGN	914 mm width. Requires 879 W x 100 H x 2 D mm Sign	each 84
GRSDS-41SIGN	1041 mm width. Requires 1006 W x 100 H x 2 D mm Sign	each 84
GRSDS-52SIGN	1321 mm width. Requires 1286 W x 100 H x 2 D mm Sign	each 97
GRSDS-60SIGN	1524 mm width. Requires 1489 W x 100 H x 2 D mm Sign	each 97

**ACCESSORIES** (available for purchase at any time)

4"LEGS	102 mm Adjustable Legs (standard on units GRSDH-41 and larger, GRSDS-36 and larger, and all duals)	Set of 4 \$47
<b>LED Bulbs – 230V adjustable bulb –</b>		
CLED-2700-230	Chef LED Bulb (emulates incandescent)	each \$101
CLED-3000-230	Chef LED Bulb (emulates halogen)	each 101
CLED-4000-230	Chef LED Bulb (emulates fluorescent)	each 101
<b>Plexi-Glass Flip-up doors on one side for GRSDS models – Not compatible with optional Sneeze Guards or Display Sign Holders in same opening –</b>		
SDS24FLIP	610 mm wide models	per shelf \$218
SDS30FLIP	762 mm wide models	per shelf 218
SDS36FLIP	914 mm wide models	per shelf 218
SDS41FLIP	1041 mm wide models	per shelf 218
SDS52FLIP	1321 mm wide models - split doors	per shelf 372
SDS60FLIP	1524 mm wide models - split doors	per shelf 372
<b>Plexi-Glass flip-up doors on one side for GRSDH models – Not compatible with optional sneeze guards or display sign holders in same opening –</b>		
GRSDH24FLIP	610 mm wide models	per shelf \$218
GRSDH30FLIP	762 mm wide models	per shelf 218
GRSDH36FLIP	914 mm wide models	per shelf 218
GRSDH41FLIP	1014 mm wide models	per shelf 218
GRSDH52FLIP	1321 mm wide models - split doors	per shelf 372
GRSDH60FLIP	1524 mm wide models - split doors	per shelf 372
GRSDH-DIV	Additional Stainless Steel Divider Rod – Horizontal model	each \$21
GRSDS-DIV	Additional Stainless Steel Divider Rod – Slant model	each 21

**COLORS AND FINISHES – INSIDE BACK COVER**
**OPTIONS**

(available at time of purchase only)

**Designer Colors – Non-standard colors are non-returnable – Glossy Gray Standard –**

RED	Warm Red	\$360
BLACK	Black	360
GRAY	Gray Granite	360
WHITE	White Granite	360
NAVY	Navy Blue	360
GREEN	Hunter Green	360
COPPER	Antique Copper	360



CLED-2700, -3000 or -4000 Accessory



SDS24FLIP Accessory shown with brackets for retrofit





## Glo-Ray® Designer Merchandising Warmers

Boost impulse sales by showcasing your hot foods in the Hatco Glo-Ray® Designer Merchandising Warmers. Designed specifically for displaying wrapped or boxed product, these warmers hold hot food safely at proper serving temperatures.

- Constructed of aluminum and stainless steel with tempered glass end panels
- Pre-focused infrared top heat directs heat to the outer edges where heat loss is greatest
- Available in single- or two-tier models
- Horizontal or slant shelves
- Product divider rods sort food displays
- Thermostatically-controlled hardcoated heated base extends holding times

- Shatter-resistant incandescent lights illuminate the holding areas and emphasize the product



**GR2SDH-30** with optional *Designer* color inset panels and accessory flip-up plexi-glass door

**NOTE:** *Designer* Series width dimensions are 159 mm greater than the number listed in model.

Merchandisers

### DESIGNER HORIZONTAL DISPLAY WARMERS

Model*	No. of Bulbs, Divider Rods	Dimensions W x D x H (Height includes legs)	Voltage single phase	Watts	Ship Weight	List Price†
<b>Single Shelf</b>						
GR2SDH-24	2, 5	768 x 686 x 459 mm	220, 240V	820	40 kg	\$3226
GR2SDH-30	2, 6	921 x 686 x 459 mm	220, 240V	1020	55 kg	3470
GR2SDH-36	2, 7	1073 x 686 x 459 mm	220, 240V	1220	59 kg	3724
GR2SDH-42	4, 8	1226 x 686 x 459 mm	220, 240V	1490	63 kg	4126
GR2SDH-48	4, 9	1378 x 686 x 459 mm	220, 240V	1690	73 kg	4531
GR2SDH-54	4, 10	1530 x 686 x 459 mm	220, 240V	1890	78 kg	4942
GR2SDH-60	6, 12	1683 x 686 x 459 mm	220, 240V	2210	85 kg	5321
<b>Dual Shelf</b>						
GR2SDH-24D	4, 10	768 x 686 x 737 mm	220, 240V	1640	57 kg	\$5313
GR2SDH-30D	4, 12	921 x 686 x 737 mm	220, 240V	2040	72 kg	5618
GR2SDH-36D	4, 14	1073 x 686 x 737 mm	220, 240V	2440	93 kg	5898
GR2SDH-42D	8, 16	1226 x 686 x 737 mm	220, 240V	2980	102 kg	6466
GR2SDH-48D*	8, 18	1378 x 686 x 737 mm	220, 240V	3380	115 kg	7020
GR2SDH-54D**	8, 20	1530 x 686 x 737 mm	220, 240V	3780	124 kg	7587
GR2SDH-60D**	12, 24	1683 x 686 x 737 mm	220, 240V	4420	149 kg	8126

### DESIGNER SLANT DISPLAY WARMERS

Model*	No. of Bulbs, Divider Rods	Dimensions W x D x H (Height includes legs)	Voltage single phase	Watts	Ship Weight	List Price†
<b>Single Shelf</b>						
GR2SDS-24	2, 5	768 x 680 x 579 mm	220, 240V	820	47 kg	\$3484
GR2SDS-30	2, 6	921 x 680 x 579 mm	220, 240V	1020	50 kg	3675
GR2SDS-36	2, 7	1073 x 680 x 579 mm	220, 240V	1220	62 kg	3995
GR2SDS-42	4, 8	1226 x 680 x 579 mm	220, 240V	1490	70 kg	4396
GR2SDS-48	4, 9	1378 x 680 x 579 mm	220, 240V	1690	74 kg	4790
GR2SDS-54	4, 10	1530 x 680 x 579 mm	220, 240V	1890	83 kg	5192
GR2SDS-60	6, 12	1683 x 680 x 579 mm	220, 240V	2210	92 kg	5560
<b>Dual Shelf</b>						
GR2SDS-24D	4, 10	768 x 680 x 860 mm	220, 240V	1640	74 kg	\$5408
GR2SDS-30D	4, 12	921 x 680 x 860 mm	220, 240V	2040	84 kg	5788
GR2SDS-36D	4, 14	1073 x 680 x 860 mm	220, 240V	2440	91 kg	6152
GR2SDS-42D	8, 16	1226 x 680 x 860 mm	220, 240V	2980	99 kg	6718
GR2SDS-48D*	8, 18	1378 x 680 x 860 mm	220, 240V	3380	116 kg	7272
GR2SDS-54D**	8, 20	1530 x 680 x 860 mm	220, 240V	3780	120 kg	7835
GR2SDS-60D**	12, 24	1683 x 680 x 860 mm	220, 240V	4420	135 kg	8374

\* When no color is specified, color inset panels and corner caps will be Black. Non-standard colors are non-returnable.

† Available with CE Mark, at no added charge.

\* Cord without plug on 240V.

\* Cord without plug on 220V.

#### All Designer Models Feature:

Usable Heated Shelf Space: All GR2SDH Models: Width of unit minus 162 x 559 D mm.

GR2SDS Single Models: Width of unit minus 162 x 559 D mm.

GR2SDS Dual Models: Width of unit minus 162 x 559 D mm.

Cord Location: Server side, bottom center.

### OPTIONS AND ACCESSORIES – PAGE 126

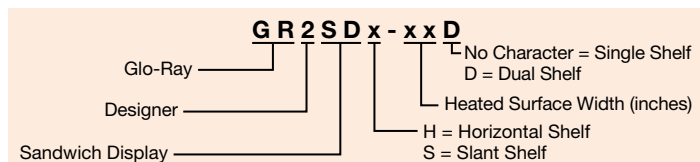



GR2SDS-24D with optional Designer color inset panels

FSDT-1 with accessory food pans

**OPTIONS** (available at time of purchase only)

**127 mm Sneeze Guard (Customer side only on Slant models) –**

GR2SD24BP	768 mm wide models	per shelf	\$ 98
GR2SD30BP	921 mm wide models	per shelf	123
GR2SD36BP	1073 mm wide models	per shelf	148
GR2SD42BP	1226 mm wide models	per shelf	173
GR2SD48BP	1378 mm wide models	per shelf	198
GR2SD54BP	1530 mm wide models	per shelf	223
GR2SD60BP	1683 mm wide models	per shelf	248

**Flip-up Doors on Front or Back –**

2SDS24FLIP	768 mm wide models	per shelf	\$162
2SDS30FLIP	921 mm wide models	per shelf	186
2SDS36FLIP	1073 mm wide models	per shelf	211
2SDS42FLIP	1226 mm wide models	per shelf	237

**Split Flip-up Doors on Front or Back –**

2SDS48FLIP	1378 mm wide models	per shelf	\$280
2SDS54FLIP	1530 mm wide models	per shelf	328
2SDS60FLIP	1683 mm wide models	per shelf	375

2SDHFRTGLS	Front Glass in lieu of Channel Dividers and Divider Rods. Cannot have Sneeze Guards or Flip-Up Doors (GR2SDH series only)	per shelf	\$ 89
------------	---	-----------	-------

SS-ITC	Indicating Temperature Control (LED) single shelf (adds 48 mm to Horizontal model depth and 45 mm to Slant model depth)		263
--------	---	--	-----

DS-ITC	Indicating Temperature Control (LED) dual shelf (adds 48 mm to Horizontal model depth and 45 mm to Slant model depth)		453
--------	---	--	-----

**ACCESSORIES** (available for purchase at any time)

2SD-DIV	Additional Stainless Steel Divider Rods	each	\$21
---------	---	------	------

**COLORS AND FINISHES – INSIDE BACK COVER**



SS-ITC Optional



DS-ITC Optional

**OPTIONS** (available at time of purchase only)

**Designer Colors –**

**Non-standard colors are non-returnable –**

**Clear Anodized Aluminum Standard –**

RED	Warm Red	\$360
BLACK	Black	360
GRAY	Gray Granite	360
WHITE	White Granite	360
NAVY	Navy Blue	360
GREEN	Hunter Green	360
COPPER	Antique Copper	360

**Designer Inset Panel Colors – Black Standard –**

RED	Warm Red	No Charge
GRAY	Gray Granite	No Charge
WHITE	White Granite	No Charge
NAVY	Navy Blue	No Charge
GREEN	Hunter Green	No Charge
COPPER	Antique Copper	No Charge

**Designer Corner Caps – Black Standard –**

DKGRAY	Dark Gray Corner Caps	No Charge
--------	-----------------------	-----------

## Heated LED Merchandisers



The new Heated Merchandiser with LED lighting is sleekly designed to safely hold hot packaged food to attract your grab-and-go customers. Available in slant or horizontal shelves, the Heated LED Merchandising Warmers are offered in both single and dual shelf models.

- Choose from slant or horizontal, single or dual shelf models
- Infrared heat safely holds hot packaged product for hours
- High efficiency LED lighting creates better illumination of food product in the holding area
- Feature a thermostatically-controlled hardcoated heated base shelf
- Hinged glass side panels are held in place magnetically and swing out for easy cleaning
- An optional Indicating Temperature Control (ITC) enhances accurate control of temperature



HXMS-36D in standard Designer Black

Merchandisers

### HORIZONTAL HEATED LED MERCHANDISERS

Model	Divider Rods	Dimensions (W x D x H) <i>Height includes legs</i>	Heated Shelf Space (W x D x H)	Voltage	Watts	Amps	Ship Weight*	List Price†
<b>Horizontal Single Shelf</b>								
HXMH-24	5	709 x 725 x 555 mm	567 x 552 mm	230V	671	2.9	55 kg	\$3480
HXMH-30	6	861 x 725 x 555 mm	720 x 552 mm	230V	863	3.8	60 kg	3724
HXMH-36	7	1013 x 725 x 555 mm	872 x 552 mm	230V	1055	4.6	66 kg	3971
HXMH-42	8	1166 x 725 x 555 mm	1025 x 552 mm	230V	1201	5.2	73 kg	4374
HXMH-48	9	1318 x 725 x 555 mm	1177 x 552 mm	230V	1392	6.1	86 kg	4774
HXMH-54	10	1471 x 725 x 555 mm	1329 x 552 mm	230V	1585	6.9	91 kg	5175
HXMH-60	12	1623 x 725 x 555 mm	1482 x 552 mm	230V	1777	7.7	94 kg	5543
<b>Horizontal Dual Shelf</b>								
HXMH-24D	10	709 x 725 x 835 mm	567 x 552 mm	230V	1342	5.8	73 kg	\$5605
HXMH-30D	12	861 x 725 x 835 mm	720 x 552 mm	230V	1726	7.5	84 kg	5987
HXMH-36D	14	1013 x 725 x 835 mm	872 x 552 mm	230V	2110	9.2	93 kg	6258
HXMH-42D	16	1166 x 725 x 835 mm	1025 x 552 mm	230V	2402	10.4	100 kg	6819
HXMH-48D	18	1318 x 725 x 835 mm	1177 x 552 mm	230V	2784	12.1	111 kg	7365
HXMH-54D	20	1471 x 725 x 835 mm	1329 x 552 mm	230V	3170	13.8	123 kg	7917
HXMH-60D	24	1623 x 725 x 835 mm	1482 x 552 mm	230V	3554	15.5	136 kg	8433

### SLANT HEATED LED MERCHANDISERS

Model	Divider Rods	Dimensions (W x D x H) <i>Height includes legs</i>	Heated Shelf Space (W x D x H)	Voltage	Watts	Amps	Ship Weight*	List Price†
<b>Slant Single Shelf</b>								
HXMS-24	5	709 x 715 x 551 mm	567 x 552 mm	230V	671	2.9	51 kg	\$3617
HXMS-30	6	861 x 715 x 551 mm	720 x 552 mm	230V	863	3.8	60 kg	3812
HXMS-36	7	1013 x 715 x 551 mm	872 x 552 mm	230V	1055	4.6	68 kg	4138
HXMS-42	8	1166 x 715 x 551 mm	1025 x 552 mm	230V	1201	5.2	73 kg	4546
HXMS-48	9	1318 x 715 x 551 mm	1177 x 552 mm	230V	1392	6.1	85 kg	4947
HXMS-54	10	1471 x 715 x 551 mm	1329 x 552 mm	230V	1585	6.9	93 kg	5359
HXMS-60	12	1623 x 715 x 551 mm	1482 x 552 mm	230V	1777	7.7	93 kg	5735
<b>Slant Dual Shelf</b>								
HXMS-24D	10	709 x 715 x 831 mm	567 x 552 mm	230V	1342	5.8	73 kg	\$5605
HXMS-30D	12	861 x 715 x 831 mm	720 x 552 mm	230V	1726	7.5	85 kg	5987
HXMS-36D	14	1013 x 715 x 831 mm	872 x 552 mm	230V	2110	9.2	94 kg	6341
HXMS-42D	16	1166 x 715 x 831 mm	1025 x 552 mm	230V	2402	10.4	105 kg	6918
HXMS-48D	18	1318 x 715 x 831 mm	1177 x 552 mm	230V	2784	12.1	111 kg	7484
HXMS-54D	20	1471 x 715 x 831 mm	1329 x 552 mm	230V	3170	13.8	123 kg	8058
HXMS-60D	24	1623 x 715 x 831 mm	1482 x 552 mm	230V	3554	15.5	132 kg	8606

† Available with CE Mark, at no added charge.

\* Shipping weights are approximate.

All Heated LED Merchandising Warmer Models Feature:  
Cord Location: Server side, bottom center on left side of control box.

### OPTIONS AND ACCESSORIES – PAGE 128

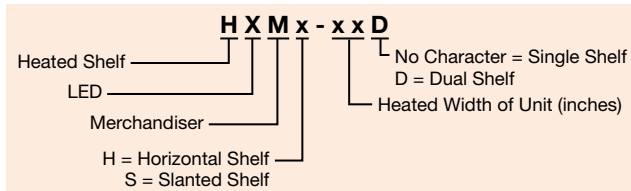





HXMS-48D in standard *Designer Black* with optional LED accent lighting in support posts

**OPTIONS** (available at time of purchase only)

*Designer Colors – Non-standard colors are non-returnable – Black standard –*

<b>RED</b>	Warm Red	<b>\$360</b>
<b>GRAY</b>	Gray Granite	<b>360</b>
<b>WHITE</b>	White Granite	<b>360</b>
<b>NAVY</b>	Navy Blue	<b>360</b>
<b>GREEN</b>	Hunter Green	<b>360</b>
<b>COPPER</b>	Antique Copper	<b>360</b>

<b>HZM-LP</b>	Red LED Accent Lighting in support post	<b>\$519</b>
<b>SS-ITC</b>	Indicating Temperature Control (LED) for single shelf	<b>263</b>
<b>DS-ITC</b>	Indicating Temperature Control (LED) for dual shelf	<b>453</b>

**Sneeze Guards – Not compatible with flip-up doors in same opening –**

<b>HZM24BP</b>	127 mm Sneeze Guard on Customer side on -24 models	<b>per shelf \$190</b>
<b>HZM30BP</b>	127 mm Sneeze Guard on Customer side on -30 models	<b>per shelf 207</b>
<b>HZM36BP</b>	127 mm Sneeze Guard on Customer side on -36 models	<b>per shelf 224</b>
<b>HZM42BP</b>	127 mm Sneeze Guard on Customer side on -42 models	<b>per shelf 246</b>
<b>HZM48BP</b>	127 mm Sneeze Guard on Customer side on -48 models	<b>per shelf 268</b>
<b>HZM54BP</b>	127 mm Sneeze Guard on Customer side on -54 models	<b>per shelf 293</b>
<b>HZM60BP</b>	127 mm Sneeze Guard on Customer side on -60 models	<b>per shelf 318</b>

**Flip-Up Doors – Not compatible with Sneeze-guards in same opening, one side only –**

<b>HZM24FLIP</b>	Plexi-Glass Flip-Up Doors on Control or Customer side on -24 models	<b>per shelf \$192</b>
<b>HZM30FLIP</b>	Plexi-Glass Flip-Up Doors on Control or Customer side on -30 models	<b>per shelf 208</b>
<b>HZM36FLIP</b>	Plexi-Glass Flip-Up Doors on Control or Customer side on -36 models	<b>per shelf 225</b>
<b>HZM42FLIP</b>	Plexi-Glass Flip-Up Doors on Control or Customer side on -42 models	<b>per shelf 246</b>
<b>HZM48FLIP</b>	Plexi-Glass Flip-Up Doors on Control or Customer side on -48 models	<b>per shelf 269</b>
<b>HZM54FLIP</b>	Plexi-Glass Flip-Up Doors on Control or Customer side on -54 models	<b>per shelf 294</b>
<b>HZM60FLIP</b>	Plexi-Glass Flip-Up Doors on Control or Customer side on -60 models	<b>per shelf 320</b>

**ACCESSORIES** (available for purchase at any time)

<b>HZM-DIV</b>	Additional Stainless Steel Divider Rods	<b>each \$21</b>
----------------	---	------------------

**COLORS AND FINISHES – INSIDE BACK COVER**





## Glo-Ray® Heated Glass Merchandisers

Hatco's Glo-Ray Heated Glass Merchandisers are perfect for holding hot wrapped or boxed foods on a buffet line or customer serving areas and features a curved design that compliments any décor.

- Blanket-style heating elements in the hardcoated base that are thermostatically-controlled
- Unique, patented heated glass shelves with infinite controls
- LED lighting allows for optimal food product display with energy savings
- Also with tempered glass side panels, heated base and box stops/sign holders on each shelf (signs not included)



**GR3SDS-39DCT** in standard Glossy Gray with standard top sign holder (signs not included)



**GR3SDS-39TCT** in standard Glossy Gray with standard top sign holder (signs not included)

Merchandisers

### HEATED GLASS MERCHANDISERS

Model†	Dimensions W x D x H (Height included legs)	Usable Heated Shelf Space W x D	Voltage Single Phase	Watts	Amps	Ship Weight	List Price
<b>Dual Shelf</b> GR3SDS-39DCT	995 x 699 x 673 mm	895 x 540 mm	230	1945-2305	8.8-9.2-9.6	84 kg	<b>\$7228</b>
<b>Triple Shelf</b> GR3SDS-39TCT	995 x 699 x 882 mm	895 x 540 mm	230	2720-3235	12.4-12.9-13.5	109 kg	<b>9516</b>

† Available with CE Mark, at no added charge.

**All Heated Glass Merchandiser Models Feature:**  
 Divider Rods included : GR3SDS-39DCT: 14 rods (7 per shelf).  
 GR3SDS-39TCT: 21 rods (7 per shelf).  
 Cord Location: Server side, bottom right corner.

#### OPTIONS (available at time of purchase only)

**Designer Colors – Non-standard colors are non-returnable – Glossy Gray Standard –**

<b>RED</b>	Warm Red	<b>No Charge</b>
<b>BLACK</b>	Black	<b>No Charge</b>
<b>GRAY</b>	Gray Granite	<b>No Charge</b>
<b>WHITE</b>	White Granite	<b>No Charge</b>
<b>NAVY</b>	Navy Blue	<b>No Charge</b>
<b>GREEN</b>	Hunter Green	<b>No Charge</b>
<b>COPPER</b>	Antique Copper	<b>No Charge</b>

#### ACCESSORIES (available for purchase at any time)

<b>3SD-DIV</b>	Additional Stainless Steel Divider Rods	<b>each \$21</b>
<b>4"LEGS</b>	102 mm Adjustable Legs	<b>Set of 4 47</b>

#### COLORS AND FINISHES – INSIDE BACK COVER

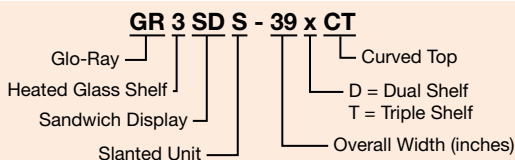

## Glo-Ray® Curved Merchandising Warmers

Looking to add a touch of class to a new point-of-sale area or to change or upgrade an existing area? Hatco's Glo-Ray® Curved Merchandising Warmer offers a unique and attractive solution for impulse sales areas.

- Single shelf and dual shelf units come standard with mirrored glass back panel
- Individual thermostatically-controlled heated base with master rocker switch maintains safe serving temperatures
- Halogen lighting allows for optimal food product display
- Humidified dual shelf unit contains a five cup capacity water reservoir
- Models with simulated stone are Swanstone®



**GRCMW-1** in standard *Designer*  
Black with food pans (not available)



**GRCMW-1DH** in standard *Designer*  
Black with food pans (not available)

### CURVED MERCHANDISING WARMER

Model†	Dimensions W x D x H	Voltage	Usable Heated Surface Space (W x D)		Watts	Ship Weight	List Price‡
			Top Shelf	Bottom Shelf			
<b>Single Shelf</b>							
<b>GRCMW-1</b>	562 x 545 x 505 mm	220, 240	—	501 x 330 mm	619-670	25 kg	<b>\$2625</b>
<b>Dual Shelf</b>							
<b>GRCMW-1D</b>	660 x 511 x 683 mm	220, 240	577 x 314 mm	577 x 396 mm	1294-1540	42 kg	<b>4983</b>
<b>Dual Shelf with Humidity – humidity on bottom shelf only</b>							
<b>GRCMW-1DH</b>	660 x 511 x 683 mm	220, 240	577 x 314 mm	577 x 396 mm	1395-1660	45 kg	<b>5328</b>

† Available with CE Mark, at no added charge.

**All Models Feature:**

Water Reservoir Capacity (GRCMW-1DH model only): 1.2 liters.  
Cord Location: Server side, bottom right corner.

### OPTIONS (available at time of purchase only)

**Designer Colors (Unit's painted surface) – Non-standard colors are non-returnable – Black standard –**

<b>RED</b>	Warm Red	<b>No Charge</b>
<b>GRAY</b>	Gray Granite	<b>No Charge</b>
<b>WHITE</b>	White Granite	<b>No Charge</b>
<b>NAVY</b>	Navy Blue	<b>No Charge</b>
<b>GREEN</b>	Hunter Green	<b>No Charge</b>
<b>COPPER</b>	Antique Copper	<b>No Charge</b>

**Simulated Stone Colors (Unit's painted surface and decorative trim inserts) –**

**Non-standard colors are non-returnable –**

<b>GGRAN</b>	Gray Granite	<b>\$451</b>
<b>BSAND</b>	Bermuda Sand	<b>451</b>
<b>NSKY</b>	Night Sky	<b>451</b>

<b>CMWDBACKFLIP</b>	Top and bottom shelf Flip-Up doors on Server's side in lieu of Mirrored Back Panel (GRCMW-1D, -1DH models only)	<b>\$302</b>
---------------------	---	--------------

<b>CMWDTOPFLIP</b>	Top shelf Flip-up Door on Customer side in lieu of Sneeze Guard (GRCMW-1D, -1DH models only)	<b>152</b>
--------------------	--	------------

### FOOD PANS AND TRIVETS – PAGE 178 COLORS AND FINISHES – INSIDE BACK COVER

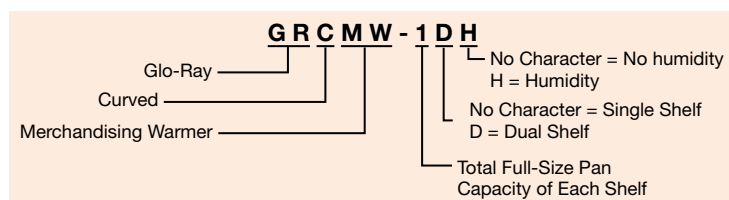

## Glo-Ray® Designer Heated Display Cases

Our Designer series Glo-Ray® Heated Display Case with curved glass and incandescent lighting will display your offering with flare and elegance. We combine our thermostatically-controlled heated base and infrared overhead heating, to blanket your offering at the perfect temperature.

- The tempered curved glass design offers a great line of sight to draw in your customers
- Exclusive cool base construction
- Rollerless sliding doors
- Available with or without controlled humidity (bottom shelf only)
- Constructed of aluminum and stainless steel with tempered glass
- Curved glass front tilts forward for easy cleaning

- Pre-focused infrared top heat directs heat to the outer edges where heat loss is greatest
- Shatter-resistant incandescent lights illuminate the food product



**GRCDH-1PD** with pan skirt and new optional flip-up doors and accessory food pans (top baking dish not available)



**GRCDH-2PD** with optional pan skirt Designer color and flip-up doors, and accessory food pans



Humidified reservoir is located in between pans



**GRCDH-3PD** shown in standard Stainless Steel with accessory food pans

Merchandisers

### DESIGNER DISPLAY CASE

Model	No. of Bulbs	Dimensions W x D x H (Height includes legs)	Usable Heated Shelf Space (W x D)	Voltage single phase	Watts	Ship Weight	List Price <sup>‡</sup>
<b>Single Shelf</b>							
GRCD-1P	2	524 x 660 x 610 mm	460 x 533 mm	220, 240	405-425	43 kg	\$4144
GRCD-2P	3	826 x 660 x 610 mm	762 x 533 mm	220, 240	710-780	55 kg	4731
GRCD-3P	3	1156 x 660 x 610 mm	1092 x 533 mm	220, 240	915-1005	69 kg	5319
<b>Dual Shelf</b>							
GRCDH-1PD	4	524 x 660 x 806 mm	460 x 533 mm	220, 240	907-905	45 kg	\$4838
GRCDH-2PD	6	826 x 660 x 806 mm	762 x 533 mm	220, 240	1080-1285	77 kg	5508
GRCDH-3PD	6	1156 x 660 x 806 mm	1092 x 533 mm	220, 240	1434-1710	95 kg	6344
<b>Single Shelf with Humidity<sup>*</sup></b>							
GRCDH-1P	2	524 x 660 x 610 mm	460 x 533 mm	220, 240	634-697	41 kg	\$4732
GRCDH-2P	3	826 x 660 x 610 mm	762 x 533 mm	220, 240	939-1052	56 kg	5320
GRCDH-3P	3	1156 x 660 x 610 mm	1092 x 533 mm	220, 240	1145-1277	71 kg	5908
<b>Dual Shelf with Humidity<sup>*</sup></b>							
GRCDH-1PD	4	524 x 660 x 806 mm	460 x 533 mm	220, 240	1136-1177	55 kg	\$5425
GRCDH-2PD	6	826 x 660 x 806 mm	762 x 533 mm	220, 240	1309-1557	79 kg	6097
GRCDH-3PD	6	1156 x 660 x 806 mm	1092 x 533 mm	220, 240	1666-1982	100 kg	6933

<sup>‡</sup> Available with CE Mark. Add \$40 for GRCD single shelf models. Add \$80 for GRCDH single shelf models and GRCD dual shelf models. Add \$120 for GRCDH dual shelf models.

<sup>\*</sup> Humidity on bottom shelf only. Includes pan skirt on bottom shelf. Pan skirts accommodate 64 mm H pans.

**All Models Feature:**

Water Reservoir Capacity (Humidified models only): 3 liters.

Cord Location: Server side, bottom right corner.

### OPTIONS AND ACCESSORIES – PAGE 132

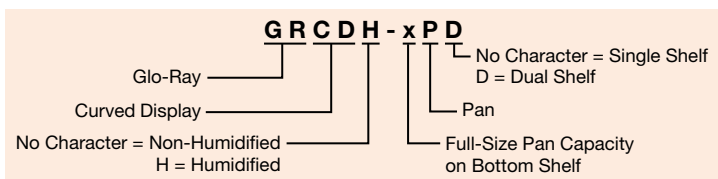



**GRCD-2PD** with optional flip-up doors and *Designer* color

### OPTIONS (available at time of purchase only)

**Self-Closing Flip-up Doors on both shelves on Customer side in lieu of Glass Front**  
(Adds 13 mm depth to unit) –

<b>CD1PDFLIP</b>	1-Pan models	<b>\$ 650</b>
<b>CD2PDFLIP</b>	2-Pan models	<b>697</b>
<b>CD3PDFLIP</b>	3-Pan models	<b>1229</b>

**Pan Skirt on bottom shelf**

(accommodates 64 mm D pans – standard on humidified models) –

<b>SKIRT-1P</b>	1-Pan model in lieu of Pan Rail	<b>\$ 44</b>
<b>SKIRT-2P</b>	2-Pan model in lieu of Pan Rail	<b>80</b>
<b>SKIRT-3P</b>	3-Pan model in lieu of Pan Rail	<b>116</b>
<b>UPPERSKIRT-2P</b>	Pan Skirt for upper shelf of 2-Pan models	<b>\$ 82</b>
<b>UPPERSKIRT-3P</b>	Pan Skirt for upper shelf of 3-Pan models	<b>164</b>

**Mirrored Glass Doors in lieu of Glass Doors (Server side only) –**

**Single Shelf Models –**

<b>MIRROR-1P</b>	1-Pan single model	<b>\$ 71</b>
<b>MIRROR-2P</b>	2-Pan single model	<b>98</b>
<b>MIRROR-3P</b>	3-Pan single model	<b>125</b>

**Dual Shelf Models –**

<b>MIRROR-1PD</b>	1-Pan dual model	<b>\$142</b>
<b>MIRROR-2PD</b>	2-Pan dual model	<b>196</b>
<b>MIRROR-3PD</b>	3-Pan dual model	<b>250</b>

**FOOD PANS AND TRIVETS – PAGE 178**

**COLORS AND FINISHES – INSIDE BACK COVER**

### OPTIONS (available at time of purchase only)

**Designer Colors –**

**Non-standard colors are non-returnable –**

**Stainless Steel Standard –**

<b>RED</b>	Warm Red	<b>\$360</b>
<b>BLACK</b>	Black	<b>360</b>
<b>GRAY</b>	Gray Granite	<b>360</b>
<b>WHITE</b>	White Granite	<b>360</b>
<b>NAVY</b>	Navy Blue	<b>360</b>
<b>GREEN</b>	Hunter Green	<b>360</b>
<b>COPPER</b>	Antique Copper	<b>360</b>

### HEATED DISPLAY CASE MAXIMUM PAN CAPACITIES\*

Model	Pan Capacity	Optional Pan Skirt Frames
<b>GRCD-1P</b>	1 Full-Size Pan	one SKIRT-1P
<b>GRCD-2P</b>	2 Full-Size Pans	one SKIRT-2P
<b>GRCD-3P</b>	3 Full-Size Pans	one SKIRT-3P
<b>GRCD-1PD</b>	<b>Top Shelf</b> 1 Half-Size Pan or 1-356 mm Pizza Pan	None
	<b>Bottom Shelf</b> 1 Full-Size Pan	one SKIRT-1P
<b>GRCD-2PD</b>	<b>Top Shelf</b> 1 Full-Size Pan and 1 Third-Size Pan or 2-356 mm Pizza Pans	one UPPERSKIRT-2P
	<b>Bottom Shelf</b> 2 Full-Size Pans	one SKIRT-2P
<b>GRCD-3PD</b>	<b>Top Shelf</b> 2 Full-Size Pans or 3-356 mm Pizza Pans	one UPPERSKIRT-3P
	<b>Bottom Shelf</b> 3 Full-Size Pans	one SKIRT-3P

\* All pan capacities shown are for non-humidified models. 64 mm deep pans recommended for bottom shelf of humidified models.





## Glo-Ray® Heated Display Cases

Designed for “show and sell” areas in any foodservice operation, the Hatco Glo-Ray® Heated Display is perfect for hot food merchandising. Top and bottom heat combine to keep all food at that “just-made” taste and temperature longer.

- Thermostatically-controlled heated base 38° - 93°C to extend holding times
- Pre-focused infrared top heat directs heat to the outer edges where heat loss is greatest
- Constructed of aluminum and stainless steel with tempered glass
- Shatter-resistant incandescent lights illuminate the food product
- Exclusive cool base construction minimizes heat transfer, keeping exterior base cool
- Rollerless sliding doors



GRHD-4PD with optional *Designer* color and mirrored glass doors and accessory food pans



GRHDH-2P with standard pan skirt, optional double side opening and accessory food pans

Merchandisers

### DISPLAY CASES

Model	No. of Bulbs	Dimensions W x D x H (Height includes legs)	Usable Heated Shelf Space (W x D)	Voltage single phase	Watts	Ship Weight	List Price <sup>‡</sup>
<b>Single Shelf</b>							
GRHD-2P	4	826 x 660 x 635 mm	712 x 546 mm	220, 240	1035-940	54 kg	\$3535
GRHD-3P	5	1156 x 660 x 635 mm	1042 x 546 mm	220, 240	1463-1350	65 kg	4038
GRHD-4P	6	1486 x 660 x 635 mm	1372 x 546 mm	220, 240	1930-1785	98 kg	4762
<b>Dual Shelf</b>							
GRHD-2PD	6	826 x 660 x 762 mm	712 x 546 mm	220, 240	1223-1310	68 kg	\$4853
GRHD-3PD	8	1156 x 660 x 762 mm	1042 x 546 mm	220, 240	1603-1755	86 kg	5448
GRHD-4PD	8	1486 x 660 x 762 mm	1372 x 546 mm	220, 240	2288-2480	104 kg	6255
<b>Single Shelf with Humidity<sup>★</sup></b>							
GRHDH-2P	4	826 x 660 x 635 mm	712 x 546 mm	220, 240	1179-1212	57 kg	\$4129
GRHDH-3P	5	1156 x 660 x 635 mm	1042 x 546 mm	220, 240	1584-1622	74 kg	4631
GRHDH-4P	6	1486 x 660 x 635 mm	1372 x 546 mm	220, 240	2253-2329	98 kg	5778
<b>Dual Shelf with Humidity<sup>★</sup></b>							
GRHDH-2PD	6	826 x 660 x 762 mm	712 x 546 mm	220, 240	1532-1582	80 kg	\$5447
GRHDH-3PD	8	1156 x 660 x 762 mm	1042 x 546 mm	220, 240	1962-2027	85 kg	6041
GRHDH-4PD	8	1486 x 660 x 762 mm	1372 x 546 mm	220, 240	2941-3024	109 kg	7271

<sup>‡</sup> Available with CE Mark. Add \$40 for GRHD single shelf models.  
 Add \$80 for GRHDH single shelf models and GRHD dual shelf models. Add \$120 for GRHDH dual shelf models.  
<sup>★</sup> Humidity on bottom shelf only. Includes pan skirt on bottom shelf. Pan skirts accommodate 64 mm H pans.

**All Models Feature:**

Water Reservoir Capacity: 2-Pan and 3-Pan Humidified Models: 3 liters.  
 4-Pan Humidified Models: 6 liters.

Doors: Separate rollerless sliding door per shelf.

Cord Location: Server side, bottom right corner.

**OPTIONS AND ACCESSORIES – PAGE 134**

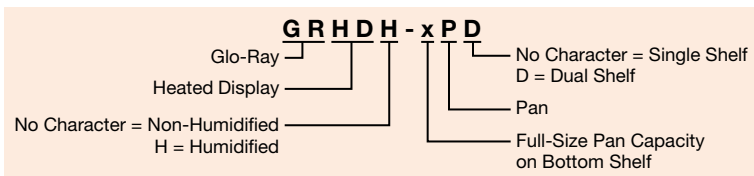



**GRHD-4PD** with optional pan skirts  
 Top shelf: one **UPPERSKIRT-4P**  
 Bottom shelf: one **SKIRT-4P**

**OPTIONS** (available at time of purchase only)

<b>Pan Skirt for 64 mm D pans on bottom shelf (standard on humidified models) –</b>		
<b>SKIRT-2P</b>	2-Pan model in lieu of Pan Rail	\$ 82
<b>SKIRT-3P</b>	3-Pan model in lieu of Pan Rail (consists of one SKIRT-1P and one SKIRT-2P)	116
<b>SKIRT-4P</b>	4-Pan Model in lieu of Pan Rail (consists of two SKIRT-2P)	164
<b>Pan Skirt for upper shelf, in lieu of Pan Stop –</b>		
<b>UPPERSKIRT-2P</b>	2-Pan models	\$ 82
<b>UPPERSKIRT-3P</b>	3-Pan models	164
<b>UPPERSKIRT-4P</b>	4-Pan models	164
<b>FLIP</b>	Flip-Up Doors on Control side in lieu of Glass Sliding Doors	No Charge
<b>Sliding Door in lieu of Fixed Glass customer panel –</b>		
<b>SLIDE-2P</b>	Per opening	\$171
<b>SLIDE-3P</b>	Per opening	188
<b>SLIDE-4P</b>	Per opening	235
<b>Flip-up Door in lieu of Fixed Glass customer panel –</b>		
<b>FLIP-2P</b>	Per opening	\$171
<b>FLIP-3P</b>	Per opening	188
<b>FLIP-4P</b>	Per opening	235
<b>Mirror Glass Sliding Door in lieu of Glass Sliding Door (server side only) –</b>		
<b>MIRROR-2P</b>	Per opening	\$ 98
<b>MIRROR-3P</b>	Per opening	125
<b>MIRROR-4P</b>	Per opening	154

**OPTIONS** (available at time of purchase only)

<b>Designer Colors – Non-standard colors are non-returnable – Stainless Steel Standard –</b>		
<b>RED</b>	Warm Red	\$360
<b>BLACK</b>	Black	360
<b>GRAY</b>	Gray Granite	360
<b>WHITE</b>	White Granite	360
<b>NAVY</b>	Navy Blue	360
<b>GREEN</b>	Hunter Green	360
<b>COPPER</b>	Antique Copper	360

**FOOD PANS AND TRIVETS – PAGE 178**  
**COLORS AND FINISHES – INSIDE BACK COVER**

**HEATED DISPLAY CASE MAXIMUM PAN CAPACITIES\***

Model	Pan Capacity	Optional Pan Skirt Frames
<b>GRHD-2P</b>	2 Full-Size Pans	One SKIRT-2P
<b>GRHD-3P</b>	3 Full-Size Pans	One SKIRT-1P and one SKIRT-2P
<b>GRHD-4P</b>	4 Full-Size Pans	Two SKIRT-2P
<b>GRHD-2PD</b>	<b>Top Shelf</b> 2 Half-Size Pans or 2, 356 mm Pizza Pans	One SKIRT-1P
	<b>Bottom Shelf</b> 2 Full-Size Pans	One SKIRT-2P
<b>GRHD-3PD</b>	<b>Top Shelf</b> 3 Half-Size Pans or 3, 356 mm Pizza Pans	One SKIRT-1P
	<b>Bottom Shelf</b> 3 Full-Size Pans	One SKIRT-1P and one SKIRT-2P
<b>GRHD-4PD</b>	<b>Top Shelf</b> 2 Full-Size Pans or 4 Half-Size Pans or 4, 356 mm Pizza Pans	One UPPERSKIRT-4P
	<b>Bottom Shelf</b> 4 Full-Size Pans	Two SKIRT-2P

\* All pan capacities shown are for non-humidified models. 64 mm deep pans recommended for bottom shelf of humidified models.

# Holding & Display Cabinets

*Cafeterias • Convenience Stores  
Catering • Concessions*

**NEW**



**FDWD-2X** with 4-shelf multi-purpose rack and optional sign holder *pg. 136*



**IHDCH-45** with accessory risers and sign holders *pg. 141*



**WFST-2X** shown with standard two doors and 4-shelf rack *pg. 143*



**MDW-1X** with optional *Designer* color and hood with backlit sign cutout on one side (sign included) *pg. 144*



**FST-1-MN** shown in standard bronze *pg. 145*



**FSHC-7W1-EE** shown in *Designer* Black, with optional right-hand hinged door *pg. 147*



**FSHC-17W1** with accessory food pans *pg. 148*



**FSHC-6W1** with accessory food pans *pg. 149*



**FS2HAC-2PT** Pass-through with accessory food pans *pg. 151*



## Flav-R-Fresh® Impulse Display Cabinets

A profitable way to create impulse food sales is with the small Flav-R-Fresh® Holding and Display Cabinet. Using controlled moisturized heat allows you to showcase your product longer using minimum counter space.

- Full-view display with tempered glass sides and door
- Controlled heat and humidity for longer holding times
- Accommodates half-size sheet pans
- Revolving or stationary display racks
- Single- or reversible double-sided opening models
- LED lights illuminate the holding areas and emphasize the product



FDWD-2 with accessory 4-tier circle rack

### IMPULSE CABINETS

Model*	Description°	Dimensions W x D x H (Height includes standard 25mm legs)	Cabinet Opening W x H	Voltage 50Hz	Watts	Ship Weight	List Price <sup>°‡</sup>
FDWD-1	1 Door w/Circle Rack w/Motor	492 x 530 x 727 mm	400 x 502 mm	220, 240	1410	41 kg	<b>\$3237</b>
FDWD-1X	1 Door w/Multi-Purpose Rack	492 x 530 x 727 mm	400 x 502 mm	220, 240	1410	41 kg	<b>3208</b>
FDWD-2	2 Doors w/Circle Rack	492 x 559 x 727 mm	400 x 502 mm	220, 240	1410	41 kg	<b>3336</b>
FDWD-2X	2 Doors w/Multi-Purpose Rack	492 x 559 x 727 mm	400 x 502 mm	220, 240	1410	41 kg	<b>3305</b>

\* Models FDWD-1 and FDWD-2 include rack motor. Models with "X" designator do not have revolving display and are NOT available for retrofit.

° Rack listed is included with unit. Other racks available – deduct price of included rack and add price of substituted rack to list price.

° For non-humidified cabinet, deduct \$210. Unit will only operate in dry mode.

‡ Available with CE Mark, add \$20.

#### All Impulse Cabinet Models Feature:

Door Hinges: Control Side: Left-hand side.

Customer Side (two-door models only): Right-hand side.

Max. Pizza Size: 381 mm diameter.

Water Tank Capacity for Humidity System: 2 liters.

Cord Location: Facing controls, left-hand side panel, lower right corner.

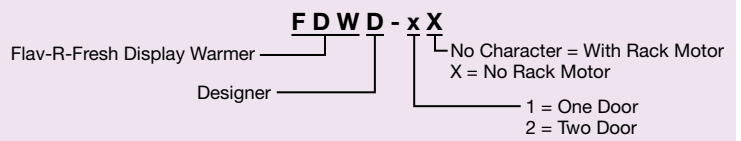

### WATER QUALITY REQUIREMENTS – PAGE 179

### OPTIONS (available at time of purchase only)

Designer Colors – Non-standard colors are non-returnable – Clear Anodized Aluminum Standard –

RED	Warm Red	<b>\$360</b>
BLACK	Black	<b>360</b>
GRAY	Gray Granite	<b>360</b>
WHITE	White Granite	<b>360</b>
NAVY	Navy Blue	<b>360</b>
GREEN	Hunter Green	<b>360</b>
COPPER	Antique Copper	<b>360</b>
<b>NEW</b> LED-NW18	Neutral White (cool) LED lighting (in lieu of standard Neutral White)	<b>No Charge</b>
FDWD-SCD	Self Closing Door in lieu of standard door (left hinge only). Must upgrade both doors on FDWD-2, -2X (not field reversible)	<b>per door \$69</b>
FDWD-6FRT	152 mm Merchandising Display Sign Holder for Control Side only (Includes metal holder only). Available in all Designer Colors to match your unit (Black is standard). Adds 29 mm to height of unit. Requires (1) sign 491 W x 157 H x 2 D mm – not included	<b>92</b>
FDWD-6SIGN	162 mm One Sided Merchandising Display Sign Holder (includes metal holder and window) – one per side, three maximum. Available in all Designer Colors to match your unit (Black is standard). Adds 32 mm to height of unit. Requires (1) sign 491 W x 159 H x 1.59 D mm – not included	<b>71</b>
FDWD-DIS	76 mm One-Sided Merchandising Display Sign Holder (includes metal holder and window) – one per side, three maximum. Available in all Designer Colors to match your unit (Black is standard). Adds 32 mm to height of unit. Requires (1) sign 484 W x 83 H x 2 D mm – not included	<b>64</b>

### ACCESSORIES (available for purchase at any time)

FDWD-LEGS	102 mm, Adjustable Legs (102-127 mm)	<b>\$ 69</b>
COUPLING	Motorless Rack Coupling for FDWD-1X and -2X models (select Circle Rack or Pretzel Tree)	<b>36</b>
FDWD4TCRR	4-Tier Circle Rack with Pizza Pan Retainers (requires Coupling for -1X or -2X models)	<b>202</b>
FDW4SMP	4-Shelf Multi-Purpose Rack (each shelf 346 W x 321 D mm)	<b>228</b>
FDW3TPT	3-Tier Pretzel Tree (requires Coupling for -1X or -2X models)	<b>228</b>
FDWD3SAR	3-Shelf Angle Rack	<b>472</b>

**DECORATIVE KIT – 139**  
**RACKS – PAGE 140**  
**FOOD PANS AND TRIVETS – PAGE 178**  
**COLORS AND FINISHES – INSIDE BACK COVER**



COUPLING Accessory



## Flav-R-Savor® Holding & Display Cabinets

Balancing a precise combination of heat and humidity, the Hatco Flav-R-Savor® Cabinets provide an attractive showcase for hot food displays and generate impulse sales. A complete range of cabinet sizes, door options and rack types allows for perfect merchandising of food products such as pizza, fried foods, bakery items, sandwiches and more.

- Full-view display with tempered glass sides and door provide maximum heat retention
- Controlled heat and humidity for longer holding times
- 3 liter stainless steel water reservoir provides all day moisture
- Low-water protection prevents heating element burnout and alerts operator to low-water condition
- Revolving or stationary display racks
- Available in two heights with single-sided or double-sided openings
- Energy efficient LED lighting to illuminate your food display



FSD-1 with 3-tier pan rack and accessory food pans



FSDT-2 with 4-tier circle rack and 102 mm legs, optional Designer Black color and accessory food pans

Holding & Display Cabinets

### DISPLAY CABINETS

Model*	Description°	Dimensions W x D x H	Cabinet Opening Dimensions W x H	Voltage 50Hz	Watts	Ship Weight	List Price <sup>°†</sup>
<b>Standard</b>							
FSD-1	1 Door w/3-Tier Circle Rack	569 x 612 x 699 mm	483 x 473 mm	220, 240	1414	50 kg	\$4189
FSD-1X	1 Door w/3-Tier Pan Rack	569 x 612 x 699 mm	483 x 473 mm	220, 240	1414	50 kg	4066
FSD-2	2 Doors w/3-Tier Circle Rack	569 x 642 x 699 mm	483 x 473 mm	220, 240	1414	52 kg	4467
FSD-2X	2 Doors w/3-Tier Pan Rack	569 x 642 x 699 mm	483 x 473 mm	220, 240	1414	51 kg	4345
<b>Tall</b>							
FSDT-1	1 Door w/4-Tier Circle Rack	569 x 612 x 826 mm	483 x 603 mm	220, 240	1414	54 kg	\$4258
FSDT-1X	1 Door w/4-Tier Pan Rack	569 x 612 x 826 mm	483 x 603 mm	220, 240	1414	54 kg	4094
FSDT-2	2 Doors w/4-Tier Circle Rack	569 x 642 x 826 mm	483 x 603 mm	220, 240	1414	55 kg	4587
FSDT-2X	2 Doors w/4-Tier Pan Rack	569 x 642 x 826 mm	483 x 603 mm	220, 240	1414	52 kg	4425

\* Models FSD-1, FSD-2, FSDT-1 and FSDT-2 include rack motor. Models with "X" designator do not have revolving display and are NOT available for retrofit.

° Rack listed is included with unit. Other racks available – deduct price of included rack and add price of substituted rack to list price.

° For non-humidified cabinet, deduct \$210. Unit will only operate in dry mode.

† Available with CE Mark, at no added charge.

#### All Models Feature:

Door Hinges: Control Side: Left-hand side.

Customer Side (Two-door models only): Right-hand side.

Max. Pan Size: 483 mm diameter.

Water Tank Capacity for Humidity System: 3 liters.

Cord Location: Facing controls, left-hand side panel, lower right corner.

#### OPTIONS AND ACCESSORIES – PAGE 138

#### DECORATIVE KIT – 139

#### RACKS – PAGE 140

#### WATER QUALITY REQUIREMENTS – PAGE 179

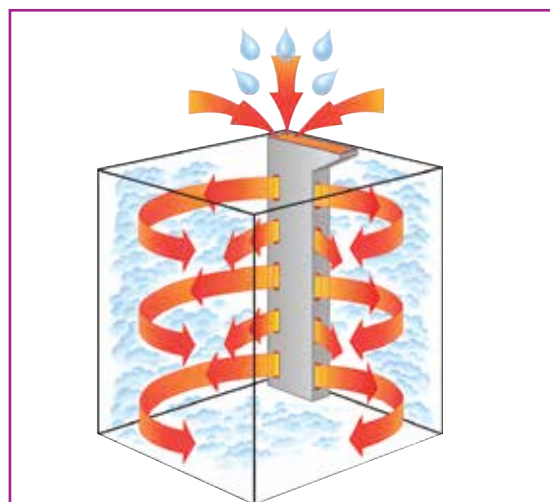
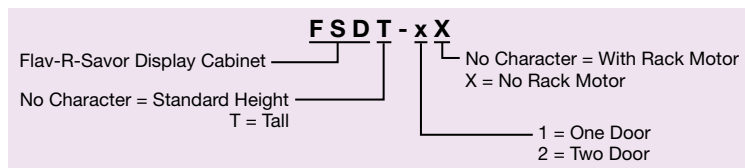

**CONTROLLED MOISTURIZED HEAT KEEPS HOT FOODS FRESH LONGER** Hatco's Flav-R-Savor® air flow pattern is designed to maintain consistent cabinet temperature without drying out foods. The precise combination of heat and humidity creates a "blanket" effect around the food. The air flow rate enables the cabinet to recover temperature rapidly after opening and closing the door.



Two FSDT-1 with 4-tier circle racks, optional sign holders (signs not included) and accessory food pans

**OPTIONS** (available at time of purchase only)

<b>THERM</b>	Mechanical Controls	No Charge
<b>FSD7SIGN</b>	191 mm Merchandising Display Sign Holder (includes metal holder and window) – one per side, three maximum. Available in all Designer Colors to match your unit (Black is standard). Adds 32 mm to height of unit. Requires (1) sign 572 W x 191 H x 2 D – sign not included	\$72

**ACCESSORIES** (available for purchase at any time)

<b>F-LEGS-4</b>	102 mm Adjustable Legs	\$66
<b>COUPLING</b>	Motorless Rack Coupling for FSD-1X, FSD-2X, FSDT-1X and FSDT-2X models (select appropriate Circle Rack or Pretzel Tree)	36

**RACKS – FSD ONLY –**

<b>FSD5SMP</b>	5-Shelf Multi-Purpose Rack (each shelf 457 W x 406 D mm)	\$301
<b>FSD3TCR</b>	3-Tier Circle Rack with Pizza Pan Retainers (requires Coupling for -1X or -2X models)	184
<b>FSD3TPR</b>	3-Tier Pan Rack (accommodates Half-Size Sheet Pans, not included)	267

**RACKS – FSDT ONLY –**

<b>FSDT7SMP</b>	7-Shelf Multi-Purpose Rack (each shelf 457 W x 406 D mm)	\$369
<b>FSDT4TCR</b>	4-Tier Circle Rack with Pizza Pan Retainers (requires Coupling for -1X or -2X models)	196
<b>FSDT5TCR</b>	5-Tier Circle Rack with Pizza Pan Retainers (requires Coupling for -1X or -2X models)	298
<b>FSDT4TPR</b>	4-Tier Pan Rack (accommodates Half-Size Sheet Pans, not included)	235
<b>FSDT3SAR</b>	3-Shelf Angle Rack (15° angle shelves) (each shelf 457 W x 413 D mm)	679
<b>FSDT3TPT</b>	3-Tier Pretzel Tree (requires Coupling for -1X or -2X models)	321

**COLORS AND FINISHES – INSIDE BACK COVER**

**OPTIONS**

(available at time of purchase only)

**Designer Colors –**

**Non-standard colors are non-returnable – Clear Anodized Aluminum Standard –**

<b>RED</b>	Warm Red	\$360
<b>BLACK</b>	Black	360
<b>GRAY</b>	Gray Granite	360
<b>WHITE</b>	White Granite	360
<b>NAVY</b>	Navy Blue	360
<b>GREEN</b>	Hunter Green	360
<b>COPPER</b>	Antique Copper	360



## Decorative Kit for FDWD, FSD, FSDT models only

Transform your Hatco Flav-R-Savor® Holding & Display Cabinet from a "heated box" into a *Designer Merchandiser* with a variety of simple accessory additions. Create a new look and feel to your décor.

- The curved hinged header allows easy access to controls and water fill cup, and gives a great area to brand your food product with a magnetic sign (sign not included)
- The base skirt completes the transformation and gives an additional branding area. Available in flat or curved panels for front and/or back of unit
- Signs can be decals or magnetic
- Signs not included



FSDT-1 with 4-tier circle rack and full Decorative Kit (signs not included)

Holding & Display Cabinets

### OPTIONS (available at time of purchase only) (additional lead time required)

**Designer Colors – Non-standard colors are non-returnable – Black Standard –**

<b>RED</b>	<b>WR</b>	Warm Red	<b>No Charge</b>
<b>GRAY</b>	<b>GG</b>	Gray Granite	<b>No Charge</b>
<b>WHITE</b>	<b>WG</b>	White Granite	<b>No Charge</b>
<b>NAVY</b>	<b>NB</b>	Navy Blue	<b>No Charge</b>
<b>GREEN</b>	<b>HG</b>	Hunter Green	<b>No Charge</b>
<b>COPPER</b>	<b>AC</b>	Antique Copper	<b>No Charge</b>

### ACCESSORIES (available for purchase at any time)

**Side Insets – must choose Designer Color – Black Standard –**

<b>FSD-INSET1</b> ①	Two Crescent Inset Panels for FSD models	<b>\$72</b>
<b>FSD-INSET2</b> ②	Two Wave Inset Panels for FSD models	<b>72</b>
<b>FSDT-INSET1</b> ①	Two Crescent Inset Panels for FSDT models	<b>72</b>
<b>FSDT-INSET2</b> ②	Two Wave Inset Panels for FSDT models	<b>72</b>
<b>FDWD-INSET1</b> ①	Two Crescent Inset Panels for FDWD models	<b>72</b>
<b>FDWD-INSET2</b> ②	Two Wave Inset Panels for FDWD models	<b>72</b>

**Top Covers – must choose Designer Color – Black Standard –**

<b>FSD-CTLH</b> ①	Curved Hinged Header on control side (Fits 609 W x 149 H mm sign) for FSD and FSDT models	<b>\$254</b>
<b>FDWD-CTLH</b> ①	Curved Hinged Header on control side (Fits 520 W x 123 H sign) for FDWD models	<b>216</b>
<b>FSD-CUSH</b> ②	Curved Header on non-control side (Fits 609 W x 149 H mm sign) for FSD and FSDT models	<b>185</b>
<b>FDWD-CUSH</b> ②	Curved Header on non-control side (Fits 520 W x 123 H sign) for FDWD models	<b>158</b>

**Base Skirts – requires 102 mm Adjustable Legs (not included)**

**– must choose Designer Color – Black Standard –**

<b>FSD-SQB</b>	One Flat Front Panel⑥ and one Flat Back Panel⑦ (Fits 508 W x 93 H mm sign) and two Flat Side Panels⑤ (Fits 473 W x 93 mm H sign) for FSD and FSDT models	<b>\$218</b>
<b>FDWD-SQB</b>	One Flat Front Panel⑥ and one Flat Back Panel⑦ (Fits 438 W x 96 H mm sign) and two Flat Side Panels⑤ (Fits 393 W x 96 mm H sign) for FDWD models	<b>285</b>
<b>FSD-1CB</b>	One Curved Front Panel③ (Fits 647 W x 93 H mm sign) and one Flat Back Panel⑦ (Fits 508 W x 93 H mm sign) and two Flat Side Panels⑤ (Fits 473 W x 93 mm H sign) for FSD and FSDT models	<b>392</b>
<b>FDWD-1CB</b>	One Curved Front Panel③ (Fits 660 W x 92 H mm sign) and one Flat Back Panel⑦ (Fits 508 W x 92 H mm sign) and two Flat Side Panels⑤ (Fits 473 W x 92 mm H sign) for FDWD models	<b>381</b>
<b>FSD-2CB</b>	One Curved Front Panel③ and one Curved Back Panel④ (Fits 647 W x 93 H sign) and two Flat Side Panels⑤ (Fits 473 W x 93 mm H sign) for FSD and FSDT models	<b>565</b>
<b>FDWD-2CB</b>	One Curved Front Panel③ and one Curved Back Panel④ (Fits 565 W x 96 H sign) and two Flat Side Panels⑤ (Fits 393 W x 96 mm H sign) for FDWD models	<b>480</b>
<b>F-LEGS-4</b>	102 mm Adjustable Legs for FSD and FSDT models	<b>\$66</b>
<b>FDWD-LEGS</b>	102 mm Adjustable Legs for FDWD models	<b>69</b>

### COLORS AND FINISHES – INSIDE BACK COVER

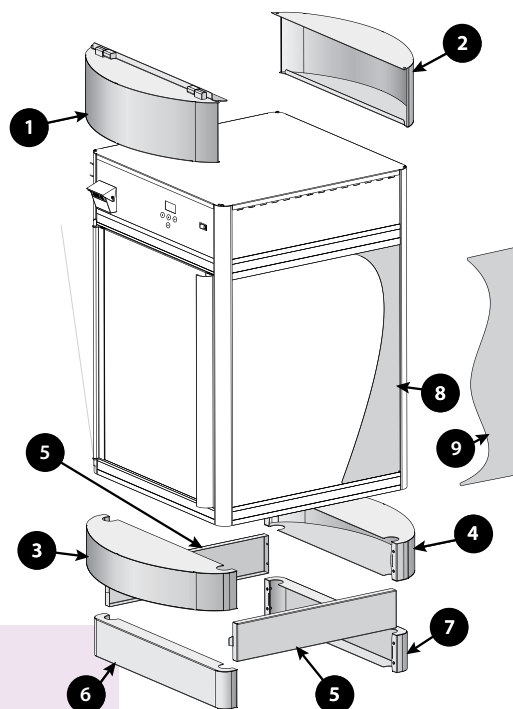



## Display Rack Selections

### Racks For FDWD Models (Page 136)

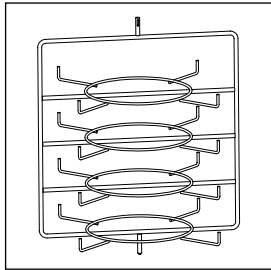

**4-Tier Circle Rack  
FDWD4TCRR**  
(Max. 381 mm dia. pans)  
(83 mm between tiers)

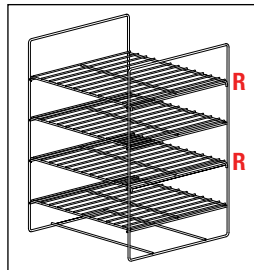

**4-Shelf Multi-Purpose  
Rack FDWD4SMP**  
(Max. 457 x 330 mm)  
(Half-Size Sheet Pans fit  
FDWD-2 and -2X models only)  
(95 mm between shelves)

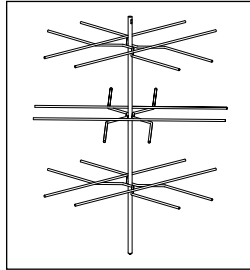

**3-Tier Pretzel Tree  
FDWD3TPT**  
(149 mm between tiers)

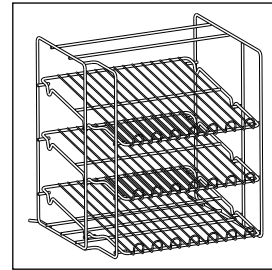

**3-TIER ANGLE RACK  
FDWD3SAR**  
(137 mm between tiers)

Holding & Display Cabinets

### Racks For FSD/FSDT Models (Page 137)

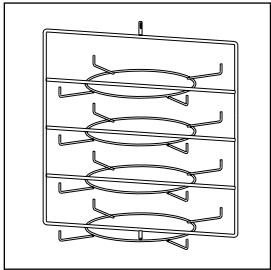

**FSDT 4-Tier Circle Rack  
FSDT4TCR**  
(Max. 483 mm dia. pans)  
(117 mm between tiers)

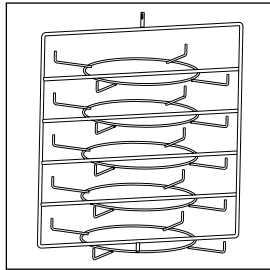

**5-Tier Circle Rack  
FSDT5TCR**  
(Max. 483 mm dia. pans)  
(98 mm between tiers)

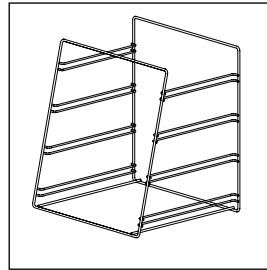

**FSDT 4-Tier Pan Rack  
FSDT4TPR** (Max. 457 x 330 mm  
Half-Size Sheet Pans)  
(89 mm between tiers)

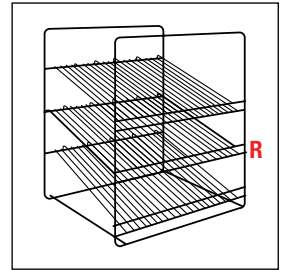

**FSDT 3-Shelf Angle Rack  
FSDT3SAR**  
(89 mm between shelves)

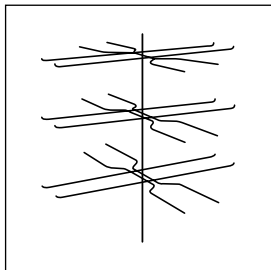

**FSDT 3-Tier Pretzel Tree  
FSDT3TPT**  
(149 mm between tiers)

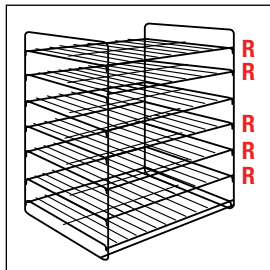

**FSDT 7-Shelf Multi-Purpose  
Rack FSDT7SMP**  
(Max. 457 x 330 mm Half-Size  
Sheet Pans)  
(64 mm between shelves)

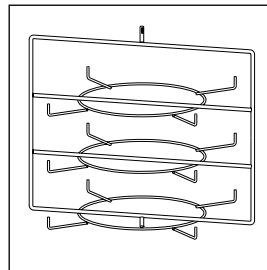

**FSDT 3-Tier Circle Rack  
FSDT3TCR**  
(117 mm between tiers)

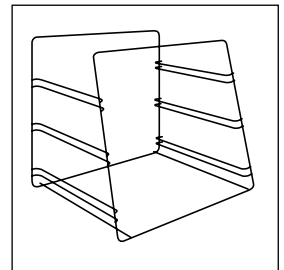

**FSD 3-Tier Pan Rack  
FSD3TPR**  
(89 mm between tiers)

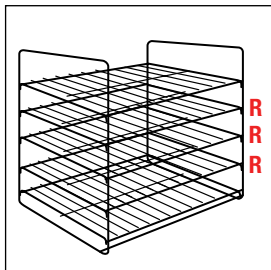

**FSD 5-Shelf Multi-Purpose  
Rack FSD5SMP**  
(64 mm between shelves)

**R Removable Shelves**





## Intelligent Heated Display Cabinet, Humidified

Hatco's Intelligent Heated Display Cabinet Humidified is the perfect way to showcase your pizzas and more. Regulating air temperature while at the same time balancing the humidity levels provides the best environment for food products. With 360° viewing, your food is guaranteed to get all the attention.

- Air flow PATTERN IS DESIGNED TO MAINTAIN CONSISTENT CABINET TEMPERATURE WITHOUT DRYING OUT FOOD
- AIR FLOW SYSTEM ENABLES THE CABINET TO RECOVER TEMPERATURE RAPIDLY AFTER OPENING AND closing the door
- LCD touchscreen display on back of unit controls temperature, humidity and up to eight timers for each food location
- Energy efficient LED lighting to illuminate your food display
- USB port on back of unit makes it easy to establish standard, pre-programmed settings for consistency and reliability
- Adjustable arms can move up and down the back supports (unit can hold up to six pizza arms)
- The Arm is designed to hold maximum 559 mm pizza pan



**IHDCH-45** shown with accessory risers



**IHDCH-28** shown with accessory two arms and one shelf

Holding & Display Cabinets

**NOTE:** Water filter, strainer and tubing are included with each cabinet to be installed on water supply connection.

### INTELLIGENT HEATED DISPLAY CABINETS WITH HUMIDITY

Model	Dimensions W x D x H	Cabinet Opening Dimensions (W x H)	Voltage	Watts	Amps	Ship Weight	List Price
IHDCH-28	718 x 728 x 766 mm	558 x 525 mm	220-240	2596-3090	11.8-12.8	100 kg	\$ 9120
IHDCH-45	1149 x 728 x 766 mm	457 x 530 mm	220-240	2596-3090	11.8-12.8	123 kg	10515

**All Intelligent Heated Display Cabinet Models Feature:**

**Models Shipped With: IHDCH-28:** Stainless Steel unit with single french door, touchscreen controller, a lighted Power On/Off (I/O) switch, an air heating/circulation system, a humidity system, a USB port and LED display lights.

**IHDCH-45:** Stainless Steel unit with sliding glass doors, touchscreen controller, a lighted Power On/Off (I/O) switch, an air heating/circulation system, a humidity system, a USB port, LED display lights and four adjustable arms.

**Cord Location:** Servers side, bottom left corner.

**OPTIONS AND ACCESSORIES – PAGE 142**  
**WATER QUALITY REQUIREMENTS – PAGE 179**

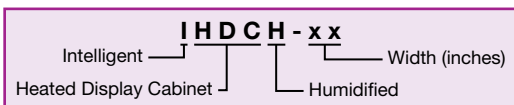



IHDCH-45 shown with standard arms, accessory risers and sign holders

**OPTIONS** (available at time of purchase only)

**Designer Colors – Non-standard colors are non-returnable – Stainless Steel Standard –**

<b>IHDCH-BK</b>	Unit in <i>Designer Black</i> in lieu of Stainless Steel unit	<b>\$360</b>
<b>IHDCHARM-BK-45</b>	Four adjustable Arms in <i>Designer Black</i> in lieu of four Stainless Steel Arms for IHDCH-45	<b>205</b>
<b>IHDCHBASE-BK-28</b>	Inside base in <i>Designer Black</i> in lieu of Stainless Steel base for IHDCH-28	<b>20</b>
<b>IHDCHBASE-BK-45</b>	Inside base in <i>Designer Black</i> in lieu of Stainless Steel base for IHDCH-45	<b>26</b>
<b>FRTDOOR-28</b>	Front, swing out, self closing door for IHDCH-28 (adds 51 mm to depth)	<b>684</b>

**ACCESSORIES** (available for purchase at any time)

<b>ADJARM-SS-28</b>	Adjustable Arm in Stainless Steel for IHDCH-28	<b>each \$ 140</b>
<b>ADJARM-SS-45</b>	Adjustable Arm in Stainless Steel for IHDCH-45	<b>each 145</b>
<b>ADJARM-BK-28</b>	Adjustable Arm in <i>Designer Black</i> for IHDCH-28	<b>each 170</b>
<b>ADJARM-BK-45</b>	Adjustable Arm in <i>Designer Black</i> for IHDCH-45	<b>each 196</b>
<b>SHELF-SS-28</b>	Shelf in Stainless Steel for IHDCH-28	<b>each 190</b>
<b>SHELF-BK-28</b>	Shelf in <i>Designer Black</i> for IHDCH-28	<b>each 160</b>
<b>RISER12-SS</b>	305 mm diameter x 38 mm H Riser in Stainless Steel	<b>21</b>
<b>RISER12-BK</b>	305 mm diameter x 38 mm H Riser in <i>Designer Black</i>	<b>31</b>
<b>DOORLOCKIHDCH</b>	Front Door lock for IHDCH-28 only	<b>19</b>
<b>RO KIT</b>	Reverse Osmosis System with storage tank	<b>1287</b>
<b>REGKIT</b>	Water Pressure Regulator Kit (regulator, gauge and shut-off valve)	<b>296</b>

**SIGN HOLDERS (signs not included) – recommended sign size: 50 x 88 mm –**

<b>SGNHOLD-BASE-SS</b>	Sits on base of unit in Stainless Steel	<b>each \$13</b>
<b>SGNHOLD-BASE-BK</b>	Sits on base of unit in <i>Designer Black</i>	<b>each 25</b>
<b>SGNHOLD-LARM-SS</b>	Customer left-hand side in Stainless Steel (clips onto Arm)	<b>each 15</b>
<b>SGNHOLD-LARM-BK</b>	Customer left-hand side in <i>Designer Black</i> (clips onto Arm)	<b>each 29</b>
<b>SGNHOLD-RARM-SS</b>	Customer right-hand side in Stainless Steel (clips onto Arm)	<b>each 15</b>
<b>SGNHOLD-RARM-BK</b>	Customer right-hand side in <i>Designer Black</i> (clips onto Arm)	<b>each 29</b>

**FOOD PANS AND TRIVETS – PAGE 178**  
**COLORS AND FINISHES – INSIDE BACK COVER**

## Flav-R-Savor® Humidified Large Capacity Holding Cabinets

Hatco Large Capacity Holding Cabinets hold more product at proper serving temperatures than standard size models. This allows for food to be prepared in advance of peak serving periods, while placing product in full-view cabinets to increase impulse sales.

- Full-view display with tempered glass sides and incandescent lights to illuminate holding area
- Optional self-closing sliding doors for self-serve applications
- Optional self-closing sliding doors, self-closing French doors, halogen bulbs and 4" adjustable legs available
- Multi-purpose display racks included



**WFST-2X** with 4-shelf multi-purpose rack, optional *Designer* color and self-closing sliding doors and accessory pans, and 102 mm legs



**WFST-1X** with 4-shelf multi-purpose rack. Decals and pans not included

Holding &  
Display Cabinets

### WIDE CAPACITY CABINETS

Model	Bulbs	Description	Dimensions W x D x H	Cabinet Opening W x H	Voltage Single Phase	Hz	Watts	Ship Weight	List Price <sup>†</sup>
<b>WFST-1X</b>	4	2 Doors w/4-shelf Rack	814 x 641 x 831 mm	711 x 557 mm	220, 240	50/60	1790	83 kg	<b>\$7361</b>
<b>WFST-2X</b>	4	4 Doors w/4-shelf Rack	814 x 703 x 831 mm	711 x 557 mm	220, 240	50/60	1790	85 kg	<b>7855</b>

† CE Mark not available.

#### All Large Capacity Cabinet Models Feature:

Available Shelf Space: 666 W x 501 D mm. Holds one full-size sheet pan per shelf.

Water Tank Capacity for Humidity System: 3 liters.

Cord Location: Servers side, left-hand side panel, lower right corner.

### WATER QUALITY REQUIREMENTS – PAGE 179

#### OPTIONS (available at time of purchase only)

**Designer Colors – Non-standard colors are non-returnable –  
– Clear Anodized Aluminum Standard –**

<b>RED</b>	Warm Red	<b>\$360</b>
<b>BLACK</b>	Black	<b>360</b>
<b>GRAY</b>	Gray Granite	<b>360</b>
<b>WHITE</b>	White Granite	<b>360</b>
<b>NAVY</b>	Navy Blue	<b>360</b>
<b>GREEN</b>	Hunter Green	<b>360</b>
<b>COPPER</b>	Antique Copper	<b>360</b>
<b>1SLIDE-DR</b>	Self-closing Sliding Doors in lieu of standard Hinged Doors on one side only (WFST-2X model only)	<b>\$389</b>
<b>FRSELFLOSE</b>	Self-closing French Doors	<b>per side 120</b>

#### ACCESSORIES (available for purchase at any time)

<b>FSTCR-LEG</b>	102 mm Adjustable Legs	<b>\$66</b>
------------------	------------------------	-------------

### FOOD PANS AND TRIVETS – PAGE 178

### COLORS AND FINISHES – INSIDE BACK COVER

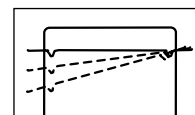
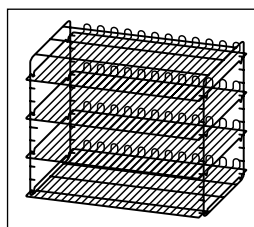

**WFST 4-Shelf  
Multi-Purpose Rack**  
Adjustable Shelves  
in 51 mm increments

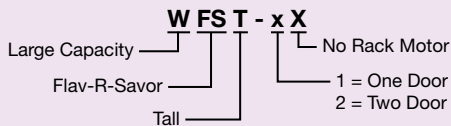

## Mini Display Warmers

The Hatco Mini Display Warmer is perfect for cookies, pastries, wrapped or boxed sandwiches or any other product that does not require humidity. Hot air circulates throughout the entire cabinet, keeping food at safe serving temperatures. The small footprint takes up little of your valuable counterspace while merchandising your breakfast, lunch or dinner offerings.

- Magnetically adjustable shelves allow horizontal or slanted displays
- Tempered glass sides and incandescent light showcase your food
- Thermostatic control with rocker switch
- Field reversible door hinge location
- Available as a 1-door or a 2-door pass-through model
- Doors may be field converted to any side
- Optional black hood with backlit graphic sign cut-out on one side (sign included)

**MDW-1X** with standard *Designer* color and optional hood with backlit sign cut-out on one side (sign included)



Magnetically adjustable shelves are easy and offer quick adjustability for different food products

### MINI DISPLAY WARMERS - NON-HUMIDIFIED

Model	Description	Dimensions W x D x H	Cabinet Opening W x H	Voltage	Watts	Ship Weight	List Price <sup>‡</sup>
MDW-1X	1 Door w/3 Shelves	400 x 432 x 646 mm	315 x 396 mm	230	510	21 kg	\$1997
MDW-2X	2 Doors w/3 Shelves	400 x 465 x 646 mm	315 x 396 mm	230	510	24 kg	2074

<sup>‡</sup> Available with CE Mark, at no added charge.

#### All Mini Display Warmer Models Feature:

Door Hinges: Control Side: Left-hand side.

Customer Side (two-door models only): Right-hand side.

Cord Location: Servers side, lower right corner.

### OPTIONS (available at time of purchase only)

**Designer Color for Posts, Base and Top Trim – Non-standard colors are non-returnable – Black Standard**

<b>RED</b>	Warm Red	<b>No Charge</b>
<b>GRAY</b>	Gray Granite	<b>No Charge</b>
<b>WHITE</b>	White Granite	<b>No Charge</b>
<b>NAVY</b>	Navy Blue	<b>No Charge</b>
<b>GREEN</b>	Hunter Green	<b>No Charge</b>
<b>COPPER</b>	Antique Copper	<b>No Charge</b>
<b>BCKLIT-MDW</b>	Hood with Backlit Sign Cut-out on one side - Black only (sign included)	<b>\$102</b>

### COLORS AND FINISHES – INSIDE BACK COVER

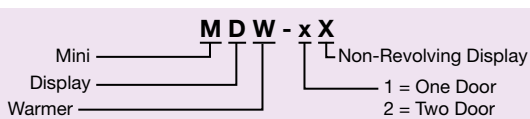



## Macho Nacho® Chip Warmers

Keep your nacho chips hot, fresh and crisp with Hatco's Macho Nacho Chip Warmer. This highly-visible heated merchandiser circulates air to prevent the loss of natural oils, eliminating the need to frequently replace stale chips.

- Keeps chips hot, fresh and crisp longer, reducing refill time and minimizing waste
- Specialty cabinet to hold and merchandise bulk nacho chips
- Special ductwork forces dry heat through chips from the bottom up
- Special two-door access for easy loading and serving
- 11 kg or 18 kg capacity
- Shatter-resistant incandescent lights illuminate the holding areas and emphasize the product



FDWD-1-MN



FST-1-MN shown in standard Bronze

Holding & Display Cabinets

### CHIP WARMERS – NON-HUMIDIFIED

Model	Dimensions W x D x H	Cabinet Opening (W x H)		Product Capacity	Voltage	Watts	Ship Weight	List Price <sup>†</sup>
		Upper Door	Lower Door					
FDWD-1-MN	492 x 607 x 728 mm	416 x 233	416 x 230	11 kg	220, 240	950-1129	46 kg	\$3273
FST-1-MN	581 x 686 x 831 mm	474 x 286	474 x 252	18 kg	220, 240	1219-1252	60 kg	4606

† CE Mark not available.

**All Chip Warmer Models Feature:**

Decal Size: FDWD-1-MN: 423 W x 139 H mm.

FST-1-MN: 473 W x 152 H mm.

Cord Location: Facing controls, left-hand side panel, lower right corner.

**F x x x - 1 - M N**

FDWD = 11 kg Chip Capacity  
FST = 18 kg Chip Capacity

— Macho Nacho Unit  
— Single Side Opening



### Flav-R-Savor® Tall Non-Humidified Holding Cabinets

Be prepared to serve ready-to-go pizzas with Hatco's Flav-R-Savor® Tall Dry Holding Cabinets. An eight-shelf rack with 127 mm centers will hold a maximum of 16 boxed (457 Sq x 59 H mm maximum) or 8 bagged pizzas.

- Great for boxed or bagged carryout pizzas
- Tempered glass throughout for excellent visibility, improving product rotation
- Even, constant cabinet temperatures with no humidity
- Two, shatter-resistant, incandescent lights at the back top of the unit to illuminate product
- Units come with an eight-shelf rack, six of which are removable



PFST-2X with standard stainless steel 8-shelf rack

Holding & Display Cabinets

#### TALL HOLDING CABINETS - NON-HUMIDIFIED

Model	Description	Dimensions W x D x H	Opening Dimensions W x H	Available Shelf Space W x D x H	Voltage	Ship Weight	List Price <sup>‡</sup>
PFST-1X	1 Door	581 x 635 x 1448 mm	476 W x 1026 H mm	457 x 457 x 117 mm	220, 240	91 kg	\$6099
PFST-2X	2 Doors	581 x 692 x 1448 mm	476 W x 1026 H mm	457 x 457 x 117 mm	220, 240	94 kg	6418

‡ CE Mark not available.

#### All Tall Dry Holding Cabinet Models Feature:

Models Shipped with: PFST-1X, -2X: Stainless Steel body, an eight-shelf rack with 6 removable shelves in standard stainless steel, new latching handle, 127 mm locking casters, cord and plug.

Cord Location: Facing controls, left-hand side panel, lower right corner.

#### OPTIONS (available at time of purchase only)

Designer Colors – Non-standard colors are non-returnable –  
– Clear Anodized Aluminum Standard –

**BLACK** Black **\$360**

#### COLORS AND FINISHES – INSIDE BACK COVER





## Flav-R-Savor® Portable Holding Cabinets

Hatco's energy efficient Flav-R-Savor® Portable Holding Cabinets will keep prepared foods at optimum serving temperatures for hours. The thermostatically-controlled heat and humidity allows food to be prepared in advance of peak serving periods.

- Allows you to hold product longer while saving you money through increased energy efficiencies
- Electronic control with digital read out, temperature range of 27°- 93°C and humidity controller
- The lower temperature range of 27°- 38°C can be used for proofing all types of breads
- All stainless steel interior
- No heating element in direct contact with water makes the unit easier to clean
- Accommodates Gastronorm pans
- Stacking kit available
- Doors are field convertible from left to right



FSHC-7W1-EE shown in Designer Black, with optional bumper kit, and right-hand hinged door



Holding & Display Cabinets

### PORTABLE HOLDING CABINETS

Model	Description	Dimensions W x D x H	Interior Cabinet Capacity W x D	Voltage 50/60 Hz	Watts	Amps	Shipping Weight	List Price <sup>‡</sup>
FSHC-5W1-EE	Single Door	661 x 794 x 913 mm	532 x 676 mm	230	1182	5.1	113 kg	\$6887
FSHC-7W1-EE	Single Door	661 x 794 x 989 mm	532 x 676 mm	230	1182	5.1	101 kg	7237
FSHC-7W2-EE	2-Door Pass-Through	661 x 877 x 989 mm	532 x 676 mm	230	1182	5.1	105 kg	7640

‡ Available with CE Mark, at no added charge.

#### All Models Feature:

Top Surface Dimensions: 654 W x 724 D mm.

Models Shipped with: 1829 mm cord and plug, 102 mm diameter casters (with 130 mm clearance), stainless steel heavy-duty door with left-hand door hinge and adjustable rack slides (seven for the -7WX-EE units, and five for the -5W1-EE unit).

Pan Capacity: -5W1-EE: 10 full sized sheet pans or 2/1 Gastronorm pans on 41 mm spacing, 5 full sized sheet pans or 2/1 Gastronorm pans on 83 mm spacing, 20 full sized hotel pans or 1/1 Gastronorm pans on 41 mm spacing, 10 full sized hotel pans or 1/1 Gastronorm pans on 83 mm spacing.

-7Wx-EE: 14 full sized sheet pans <sup>‡</sup> or 2/1 Gastronorm pans on 35 mm spacing, 7 full sized sheet pans or 2/1 Gastronorm pans on 70 mm spacing, 14 hotel sized pans or 1/1 Gastronorm pans on 35 mm spacing.

Water Tank Capacity for Humidity System: 4 liters.

Cord Location: Recessed, back of unit, upper right side.

<sup>‡</sup>With purchase of extra pan slides.

### WATER QUALITY REQUIREMENTS – PAGE 179

#### OPTIONS (available at time of purchase only)

<b>Colors (Side Panels) – Non-standard colors are non-returnable – Black Standard –</b>		
SS	Stainless Steel	\$180
<b>Colors (Top) – Non-standard colors are non-returnable – Black Standard –</b>		
SS	Stainless Steel	\$360
EE-GLASS	Glass Door in lieu of Stainless Steel door (is not Energy Star qualified)	\$227
EE-LPCAST	Low Profile Casters (FSHC-5W1-EE model only) (deduct 57 mm from height)	No Charge
EE-PLATFORM	Platform for mounting directly on a counter in lieu of casters (deduct 105 mm from height)	No Charge
EE-STACK-BLK	Designer Black Powdercoated Stacking Hardware mounted to bottom of cabinet for two FSHC-7W1 or two FSHC-5W1 units in lieu of casters (cannot have legs on lower unit)	No Charge
EE-STACK-SS	Stainless Steel Stacking Hardware mounted to bottom of cabinet for two FSHC-7W1 or two FSHC-5W1 units in lieu of casters (cannot have legs on lower unit)	No Charge
EE-BUMPER	Bumper Hardware - only for use with standard casters (add 3 mm to height)	436
EE-4LEGS	102 mm Legs - in lieu of casters (deduct 13 mm from height)	No Charge
EE-6LEGS	152 mm Legs - in lieu of casters (add 45 mm to height)	No Charge

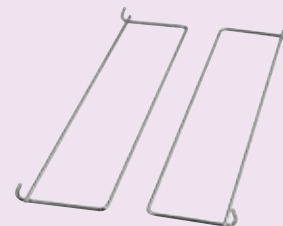

EE-1-SLIDE Accessory

#### ACCESSORIES (available for purchase at any time)

EE-1-SLIDE	Extra Pan Slides	pair \$84
------------	------------------	-----------

### FOOD PANS AND TRIVETS – PAGE 178

### COLORS AND FINISHES – INSIDE BACK COVER

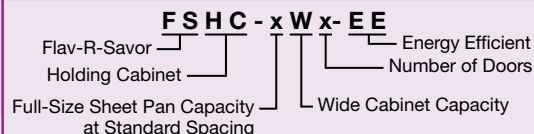

## Flav-R-Savor® Tall Humidified Holding Cabinets

The expanded capacity of Hatco's Tall Humidified Cabinets offers flexibility – giving customers more variety of menu items, and holding larger quantities of proven favorites ahead of peak serving periods. The universal slides of the FSHC-17W models will hold 17 sheet pans, or 34 steam table pans. FSHC-12W models will hold 12 sheet pans and 24 steam table pans.

- The Hatco Flav-R-Savor® Tall Humidified Holding Cabinets hold all types of hot foods at uniform optimum serving temperatures
- Electronic Controls with digital readout temperature range of 26°-93°C with precise heat and humidity settings assure uniform heating throughout the cabinet
- Using the lower temperature range of 26°-38°C allows perfect temperature for proofing all types of bread
- Lexan or stainless steel doors, full height, half height and pass through available
- All Stainless Steel interior and exterior
- Fully insulated doors, sidewalls, base and top assist in heat retention and quick recovery
- Field reversible, right- or left-hand hinged doors with magnetic latch and heavy duty plated hinges
- Fully welded tubular frame assures integrity of unit in any working environment



FSHC-17W1

### TALL HUMIDIFIED HOLDING CABINETS

Model	Description	Dimensions W x D x H (Height includes standard casters)	Cabinet Opening Dimensions W x H	Ship Weight	List Price 220, 240V†
FSHC-12W1	Single Lexan® Door	660 x 887 x 1448 mm	559 x 1105 mm	138 kg	<b>\$ 8981</b>
FSHC-12W2	2 Lexan® Doors – Pass-Through	660 x 898 x 1448 mm	559 x 1105 mm	143 kg	<b>10830</b>
FSHC-17W1	Single Lexan® Door	660 x 887 x 1862 mm	559 x 1518 mm	160 kg	<b>9128</b>
FSHC-17W1D	Single Opening w/ 2 Dutch Doors	660 x 887 x 1862 mm	559 x 1518 mm	163 kg	<b>9821</b>
FSHC-17W2	2 Lexan® Doors – Pass-Through	660 x 898 x 1862 mm	559 x 1518 mm	165 kg	<b>10907</b>
FSHC-17W2D	4 Dutch Doors – Pass-Through	660 x 898 x 1862 mm	559 x 1518 mm	177 kg	<b>12006</b>

† CE Mark not available.

#### All Tall Humidified Holding Cabinet Models Feature:

**Voltage:** 220V, 50/60Hz, 1800 watts or 240V, 50/60Hz, 2133 watts, single phase.

**Models Shipped with:** 127 mm casters (2 swivel with wheel locks and 2 rigid), universal slides for 457 x 660 mm pans or 305 x 508 mm pans.

**Pan Capacity: FSHC-12W:** 12-sheet pan capacity on 76 mm centers, adjustable on 38 mm centers, with 12 universal pan slides, designed to accommodate up to 12 sheet pans or up to 24 steam table pans.

**FSHC-17W:** 17-sheet pan capacity on 76 mm centers, adjustable on 38 mm centers, with 17 universal pan slides, designed to accommodate up to 17 sheet pans or up to 34 steam table pans.

**Water Reservoir Capacity for Humidity System:** 8 liters.

**Cord Location:** Facing controls, right-hand side panel, lower right corner.

### WATER QUALITY REQUIREMENTS – PAGE 179

#### OPTIONS (available at time of purchase only)

<b>DELUXE</b>	Deluxe Package (includes Flush Mount Handles and Full Perimeter Bumper)	<b>\$ 653</b>
<b>TRANS</b>	Transport Package - includes Stand-Off Handles, Full Perimeter Bumper, Heavy-Duty 27 x 51 mm Casters (2 swivel with wheel locks and 2 rigid), and Flush Mount Transport Latch	<b>1151</b>
<b>CORDWIND</b>	Bracket for holding cord during transport (only available with Transport Package option for -12W, 17W Models)	<b>67</b>
<b>12W-SS-DOOR</b>	Stainless Steel Door in lieu of Lexan® Door	<b>No Charge</b>
<b>17W-SS-DOOR</b>	Stainless Steel Door in lieu of Lexan® Door	<b>No Charge</b>
<b>17WD-SS-DOOR</b>	Stainless Steel Dutch Doors in lieu of Lexan® Dutch Doors (FSHC-17W models only)	<b>No Charge</b>

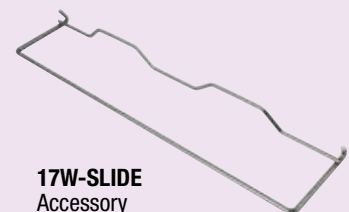

17W-SLIDE  
Accessory

#### ACCESSORIES (available for purchase at any time)

<b>17W-SLIDE</b>	Extra Pan Slides (FSHC-12W and FSHC-17W)	<b>pair \$121</b>
------------------	--	-------------------

### FOOD PANS AND TRIVETS – PAGE 178

### COLORS AND FINISHES – INSIDE BACK COVER

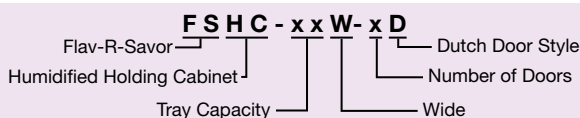



## Flav-R-Savor® Portable Holding Cabinets

Prepare food in advance of peak serving periods and safely hold it at optimum serving temperatures with the Flav-R-Savor® Portable Holding Cabinet. Thermostatically-controlled heat and humidity allows you to hold product for hours.

- Thermostatically-controlled heat and humidity holds hot food at optimum serving temperatures longer
- Allows preparation of food in advance of peak serving periods
- Accommodates Gastronorm pans
- Electrical components, controls, water reservoir and digital temperature readout are located at the top for easy access
- Reduced height – less than 762 mm high, and wider footprint for increased capacity

- Insulated side walls, field reversible glass doors, large swivel casters with wheel locks and 1829 mm recessed cord and plug are standard
- Stacking kit available



FSHC-6W1 with accessory food pans

Holding &  
Display Cabinets

### LOW PROFILE HOLDING CABINETS – HUMIDIFIED

Model	Description	Dimensions W x D x H (Height includes standard casters)	Cabinet Opening Dimensions W x H	Ship Weight	List Price 220, 240V†
FSHC-6W1	1 Door	645 x 751 x 816 mm	546 x 483 mm	76 kg	\$5850
FSHC-6W2*	2 Doors	645 x 811 x 816 mm	546 x 483 mm	82 kg	6250

† Available with CE Mark, at no added charge.

\* FSHC-6W2 is a two-door pass-through single cabinet, not two units stacked.

#### All Low Profile Holding Cabinet Models Feature:

**Voltage:** 220 or 240V, 50/60Hz, 1697 watts.

**Top Surface Dimensions:** 645 W x 657 D mm.

**Models Shipped with:** 1829 mm cord and plug, 102 mm diameter casters (with 130 mm clearance), six sets of adjustable angle slides.

**Pan Capacity:** Six 457 W x 660 D mm sheet pans or six 2/1 Gastronorm pans on 76 mm centers, eleven 457 W x 660 D mm sheet pans\*, eleven 2/1 Gastronorm pans on 38 mm centers\*, or twelve 508 W x 305 D x 64 H mm hotel pans.

**Water Tank Capacity for Humidity System:** 3 liters.

**Cord Location:** Recessed, back of unit, upper right side.

\* With purchase of extra pan slides.

### WATER QUALITY REQUIREMENTS – PAGE 179

#### OPTIONS (available at time of purchase only)

**Colors (Side Panels) – Non-standard colors are non-returnable – Silver Gray Standard –**

<b>BLACK</b>	Designer Black	<b>\$180</b>
<b>SS</b>	Stainless Steel	<b>180</b>

**Colors (Top) – Non-standard colors are non-returnable – Silver Gray Standard –**

<b>BLACK</b>	Designer Black	<b>\$180</b>
<b>SS</b>	Stainless Steel	<b>180</b>

**6W-SS-DR** Stainless Steel Door in lieu of Glass Door **\$ 78**

**HD-SS-DR** Heavy-Duty Stainless Steel Door with Positive Latch Handle **326**

**6W1-LPCAST** 51 mm Low Profile Locking Casters in lieu of standard Casters (51 mm diameter with 76 mm clearance) (overall height 756 mm) **No Charge**

**6W1-STACK** Stacking Hardware mounted to top of cabinet for two FSHC-6W1 units in lieu of Casters (Silver Gray) **73**

**CORDWIND** Bracket for holding cord during transport **30**

#### ACCESSORIES (available for purchase at any time)

**6W1-SLIDE** Extra Pan Slides **pair \$84**

### FOOD PANS AND TRIVETS – PAGE 178

### COLORS AND FINISHES – INSIDE BACK COVER



6W1-SLIDE  
Accessory

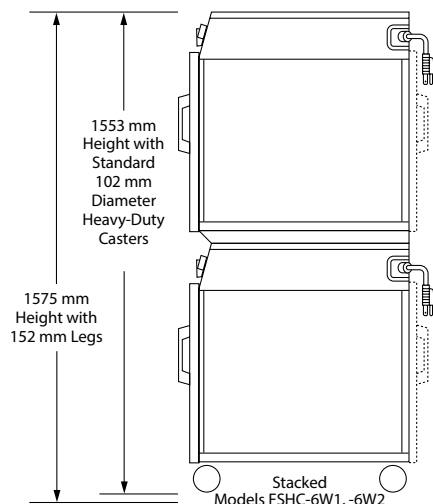
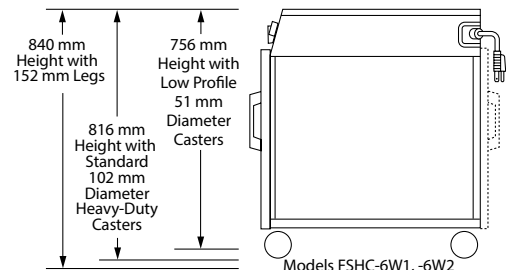
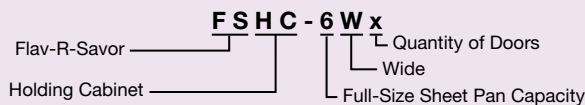

## Flav-R-Savor® Humidified Portable Holding Cabinets

Prepare food in advance of peak serving periods and safely hold it at optimum serving temperatures with the Flav-R-Savor® Portable Holding Cabinet. Thermostatically-controlled heat and humidity allows you to hold product for hours.

- Thermostatically-controlled heat and humidity holds hot food at optimum serving temperatures longer
- Allows preparation of food in advance of peak serving periods
- Accommodates Gastronorm pans
- Electrical components, controls, water reservoir and digital temperature readout are located at the top for easy access

- Insulated side walls, field reversible glass doors, large swivel casters with wheel locks and 1829 mm recessed cord and plug are standard
- Stacking kit available



FSHC-7-1 with standard 102 mm casters and accessory food pans

### PORTABLE HOLDING CABINETS – HUMIDIFIED

Model	Description	Dimensions W x D x H (Height includes standard casters)	Cabinet Opening Dimensions W x H	Ship Weight	List Price 220, 240V†
FSHC-7-1	1 Door	578 x 753 x 892 mm	470 x 559 mm	79 kg	<b>\$5903</b>
FSHC-7-2*	2 Doors	578 x 812 x 892 mm	470 x 559 mm	82 kg	<b>6306</b>

† Available with CE Mark, at no added charge.

\* FSHC-7-2 is a two-door pass-through single cabinet, not two units stacked.

#### All Portable Cabinet Models Feature:

**Voltage:** 220 or 240V, 50/60Hz, 1697 watts.

**Top Surface Dimensions:** 575 W x 657 H mm.

**Models Shipped with:** 1829 mm cord and plug, 102 mm diameter casters (with 130 mm clearance), seven sets of adjustable angle slides for 457 x 660 mm pans or 305 x 508 mm.

**Pan Capacity:** Seven 457 W x 660 D mm sheet pans on 76 mm centers, or seven 508 W x 305 D x 64 H mm hotel pans, or seven 1/1 Gastronorm pans.

**Water Tank Capacity for Humidity System:** 3 liters.

**Cord Location:** Recessed, back of unit, upper right side.

### WATER QUALITY REQUIREMENTS – PAGE 179

#### OPTIONS (available at time of purchase only)

**Colors (Side Panels) – Non-standard colors are non-returnable – Silver Gray Standard –**

<b>BLACK</b>	Designer Black	<b>\$180</b>
<b>SS</b>	Stainless Steel	<b>180</b>

**Colors (Top) – Non-standard colors are non-returnable – Silver Gray Standard –**

<b>BLACK</b>	Designer Black	<b>\$180</b>
<b>SS</b>	Stainless Steel	<b>180</b>

**SS-DR** Stainless Steel Door in lieu of Glass Door **\$ 78**

**HD-SS-DR** Heavy-Duty Stainless Steel Door with Positive Latch Handle **326**

**LPCAST** 51 mm Low Profile Casters in lieu of standard Casters (51 mm diameter with 76 mm clearance) (Overall Height 832 mm) **30**

**4LEGS** 102 mm Adjustable Legs in lieu of standard Casters **No Charge**

**6SS** 152 mm Stainless Steel Legs in lieu of standard Casters **No Charge**

**7-1-STACK** Stacking Hardware mounted to top of cabinet for two FSHC-7-1 units in lieu of Casters (Silver Gray) **103**

**CORDWIND** Bracket for Holding Cord During Transport **30**

#### ACCESSORIES

(available for purchase at any time)

**SLIDEWIRE** Wire Shelf **per shelf \$109**

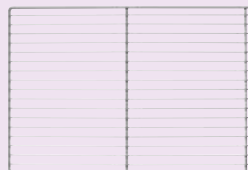

SLIDEWIRE  
Accessory

### FOOD PANS AND TRIVETS – PAGE 178

### COLORS AND FINISHES – INSIDE BACK COVER

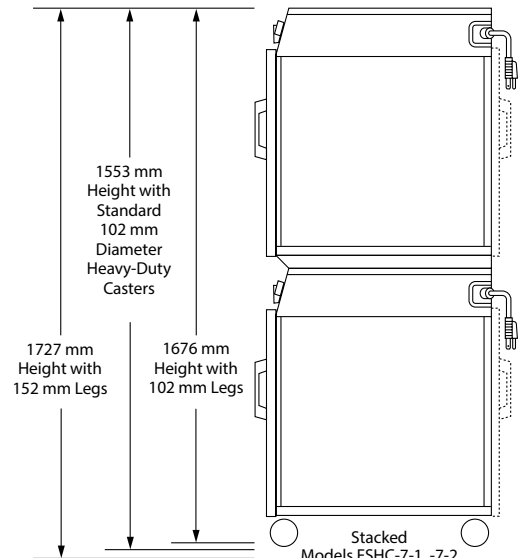
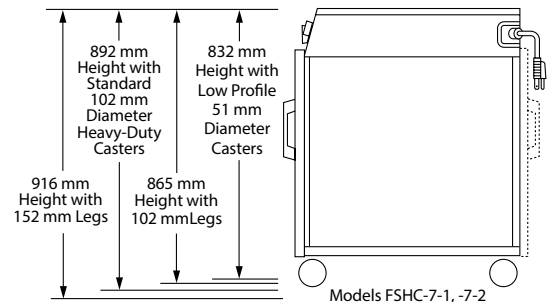
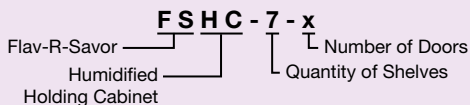

## Flav-R-Savor® Heated Air Curtain Cabinets

The patented Flav-R-Savor® Heated Air Curtain Cabinet effectively and safely holds hot food hot without the use of doors. Warm air at the front of the cabinet is forced downward, through the ducts above the opening, forming a “curtain” of heated air. A portion of the heated air is drawn toward the rear of the cabinet, warming each pan.

- Perfect for holding wrapped or sealed product like tortillas, burritos and ribs, as well as product on sheet pans like biscuits, hamburger patties and baked potatoes or fried foods in pans
- Available in 2-pan and 3-pan models, single opening or pass-through, with or without humidity
- The 2-pan pass-through accommodates two full-size sheet pans or four half-size sheet pans, and the 4-pan unit accommodates four full-size sheet pans or eight half-size sheet pans



FS2HAC-4PT with accessory food pans



FSHAC-3 with accessory food pans

Holding & Display Cabinets

### HEATED AIR CURTAIN CABINETS

Model	Description	Dimensions (W x D x H)		Cabinet Opening		Voltage	Hz	Watts	Ship Weight	List Price <sup>‡</sup>
		Height includes 102 mm legs		Dimensions (W x H)						
FSHAC-2	2-Tier Warmer	257 x 581 x 460	464 x 232 mm	220, 240	50/60	1750	46 kg	\$4614		
FSHAC-3	3-Tier Warmer	257 x 581 x 775	464 x 460 mm	220, 240	50/60	1750	48 kg	4811		
FS2HAC-2PT	2-Tier Pass Through	613 x 994 x 468	459 x 206 mm	220, 240	50	2538-3022	80 kg	6989		
FS2HAC-4PT	4-Tier Pass Through	613 x 994 x 671	464 x 410 mm	220, 240	50	3338-3362	96 kg	7631		

<sup>‡</sup> Available with CE Mark, at no added charge.

**All Air Curtain Models Feature:**

Cord Location: FSHAC-2, -3: Top of unit towards the back, middle.  
 FS2HAC-2PT, -4PT: Top of unit towards the back, left side.

### ACCESSORIES (available for purchase at any time)

**4"LEGS** 102 mm Legs (Standard on 3-Tier models) **\$47**

**FOOD PANS AND TRIVETS – PAGE 178**  
**COLORS AND FINISHES – INSIDE BACK COVER**

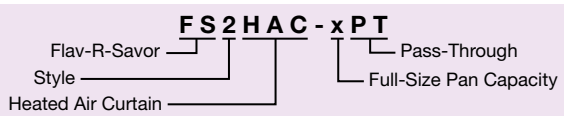

# Toasters

*Buffets • Supermarkets & Delis • Restaurants & Cafés  
Clubs & Bars • Catering • Concessions*



**ITQ-1750-2C** Intelligent Toast-Qwik® Conveyor Toaster *pg. 153*



**TQ3-2000** Toast-Qwik® Horizontal Conveyor Toaster *pg. 154*



**TQ3-500** Toast-Qwik® in optional Stainless Steel *pg. 154*



**TQ-10** Toast-Qwik® Horizontal Conveyor Toaster *pg. 155*



**TK-100** Toast King® Vertical Conveyor Toaster *pg. 157*



**TQ-805** Toast-Qwik® High Watt Horizontal Conveyor Toaster *pg. 158*





## New Toast-Qwik® Conveyor Toasters

Hatco's industry-leading Toast-Qwik Toasters have been completely redesigned to provide a great new look, easy to use touchscreen controller, and increased production capabilities. They continue to provide the best reliability, flexibility, and value of any conveyor toaster available!

- Patented ColorGuard Sensing System which monitors chamber temperature and adjusts conveyor speed to ensure consistent toast results - even in your busiest periods
- Dynamic new touchscreen controller that is easy to see and easier to use!
- Up to 12 programmable settings for precise and instant product changes
- USB port for easy uploads of program changes and software updates
- Unique new toast delivery ramp moves your product to the storage tray each and every time
- Crumb tray is removeable for easy cleaning
- 51 mm high opening Standard - 76 mm high opening available on the TQ3-500H, TQ3-900H and TQ3-2000H models for thicker bread products



**TQ3-2000**  
shown in standard  
*Designer Black*



**TQ3-500**  
shown in optional  
*Designer Warm Red*



**TQ3-900H**  
shown in optional  
*Stainless Steel*

Toasters

### HORIZONTAL CONVEYOR TOASTERS

Model	Dimensions (W x D x H) <i>Height includes legs</i>	Opening Dimensions W x H	Voltage	Watts	Ship Weight	List Price <sup>‡</sup> 220, 240V
<b>Toasts Two Slices Wide</b>						
<b>TQ3-500</b>	374 x 524 x 435 mm	258 x 51 mm	220- 240	2031-2220	25 kg	<b>\$2439</b>
<b>TQ3-500H</b>	374 x 524 x 435 mm	258 x 76 mm	220- 240	2031-2220	25 kg	<b>2439</b>
<b>TQ3-900</b>	374 x 524 x 435 mm	258 x 51 mm	220- 240	2763-3020	23 kg	<b>2602</b>
<b>TQ3-900H</b>	374 x 524 x 435 mm	258 x 76 mm	220-240	2763-3020	25 kg	<b>2602</b>
<b>Toasts Three Slices Wide</b>						
<b>TQ3-2000*</b>	475 x 536 x 435 mm	359 x 51 mm	220-240	3678-4020	30 kg	<b>\$3214</b>
<b>TQ3-2000H*</b>	475 x 536 x 435 mm	359 x 76 mm	220-240	3678-4020	30 kg	<b>3214</b>

<sup>‡</sup> Available with CE Mark, add \$100.

\* Cord without plug.

**All Horizontal Conveyor Models Feature:**

Cord Location: 1829 mm cord – back of unit, lower right corner.

### OPTIONS (available at time of purchase only)

**Designer Colors – Non-standard colors are non-returnable – Designer Black Standard –**

<b>SS</b>	Stainless Steel	<b>\$197</b>
<b>WRED</b>	Designer Warm Red	<b>No Charge</b>
<b>SSINSERT</b>	Stainless Steel toast tray insert	<b>40</b>
<b>TQ3-RAMP</b>	Extended feed ramp in lieu of existing ramp - adds 76 mm	<b>30</b>
<b>TQ3-RAMP-XL</b>	XL extended feed ramp in lieu of existing ramp - adds 229 mm (on TQ3-500 and -900 models only)	<b>40</b>

### COLORS AND FINISHES – INSIDE BACK COVER

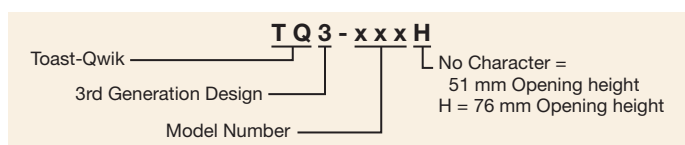

### TQ3 TOASTER AMP RATINGS

Model	220V 60Hz	240V 50/60Hz
<b>TQ3-500</b>	9.2	9.7
<b>TQ3-500H</b>	9.2	9.7
<b>TQ3-900</b>	12.1	13.1
<b>TQ3-900H</b>	12.1	13.1
<b>TQ3-2000</b>	16.7	16.8
<b>TQ3-2000H</b>	16.7	16.8



## Toast-Qwik® Conveyor Toasters

Flexibility and performance are yours with the Hatco Toast-Qwik® conveyor toasters. These toasters produce perfect golden toasting, from 300 to 1800 slices per hour. The power save mode conserves energy during non-peak serving times.

- Instant and precise adjustment of toast color with electronic infinite controls that regulate top and bottom heat
- Hatco's patented ColorGuard sensing system assures toast uniformity
- Opening height for H and HBA models is 76 mm, for all other models the opening height is 51 mm
- Insulation and an interior fan provide cool surface temperatures
- Efficient design of front or rear discharge allows unit to be placed where it is most convenient – for sending product to the operator side or to the customer/server side
- **BA models toast one side only and are for bagels and buns, cut side up**



TQ-10



TQ-400



TQ-1800H

### TOAST-QWIK® HORIZONTAL CONVEYOR TOASTERS

Model	Dimensions W x D x H (Height includes legs)	Opening Dimensions W x H	kW	Voltage	Capacity/ Minute†	Ship Weight	List Price‡ 220, 240V
TQ-10	368 x 451 x 349 mm	265 x 51 mm	1.8-2.2	220, 240	5 slices	19 kg	\$1469

### TOAST-QWIK® HORIZONTAL CONVEYOR TOASTERS

Model	Dimensions W x D* x H (Height includes legs)	Opening Dimensions W x H	kW	Voltage	Capacity/ Minute†	Ship Weight	List Price‡ 220, 240V
TQ-400	368 x 451 x 378 mm*	263 x 51 mm	1.8-2.2	220, 240	6 slices	21 kg	\$2265
TQ-400BA▼	368 x 451 x 378 mm*	263 x 51 mm	1.7-2.1	220, 240	6 slices	21 kg	2265
TQ-400H	368 x 451 x 403 mm	263 x 76 mm	2.2-2.2	220, 240	6 slices	21 kg	2265
TQ-800	368 x 578 x 422 mm*	265 x 51 mm	3.0-3.5	220, 240	14 slices	29 kg	2575
TQ-800BA▼	368 x 578 x 422 mm*	265 x 51 mm	2.7-3.3	220, 240	14 slices	28 kg	2575
TQ-800H	368 x 578 x 422 mm*	265 x 76 mm	3.0-3.5	220, 240	14 slices	29 kg	2575
TQ-800HBA▼	368 x 578 x 422 mm*	265 x 76 mm	2.7-3.3	220, 240	14 slices	29 kg	2575

#### Toasts Three Slices Wide

TQ-1800	470 x 577 x 421 mm	367 x 51 mm	3.7-4.4	220, 240	30 slices	33 kg	\$3238
TQ-1800BA ▼	470 x 577 x 421 mm	367 x 51 mm	3.8-4.5	220, 240	30 slices	34 kg	3238
TQ-1800H	470 x 577 x 421 mm	367 x 76 mm	3.9-4.6	220, 240	30 slices	34 kg	3238
TQ-1800HBA ▼	470 x 577 x 421 mm	367 x 76 mm	3.8-4.6	220, 240	30 slices	34 kg	3238

‡ Available with CE Mark, add \$50. CE Mark available for TQ-10 220, 240V at no charge.

† Toasting capacity may vary by product. Toasting of coated products not recommended.

• TQ-400 and TQ-400BA, add 64 mm to depth if using tray extension in rear.

• TQ-800, TQ-800BA, TQ-800H, TQ-800HBA, TQ-1800, TQ-1800BA, TQ-1800H and TQ-1800HBA add 165 mm to depth if using tray extension in rear.

▼ BA models toast one side only and are for bagels and buns, cut side up.

#### All Toast-Qwik® Models Feature:

Cord Location: 1829 mm - back of unit, lower right corner.

#### OPTIONS AND ACCESSORIES – PAGE 156

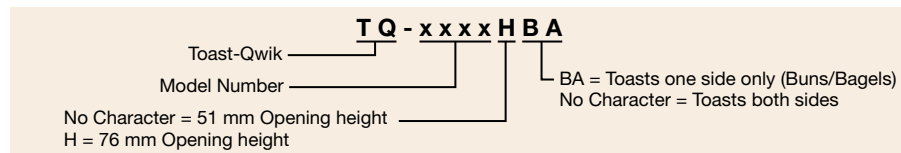

#### TQ TOASTER AMP RATINGS

Model	220V	240V
	50Hz/1 Ø	50/60Hz/1 Ø
TQ-10	8.5	9.3
TQ-400	8.5	9.2
TQ-400BA	8.0	8.8
TQ-400H	9.7	9.2
TQ-800	13.7	15.0
TQ-800BA	12.7	13.9
TQ-800H	13.7	15.0
TQ-800HBA	12.7	13.9
TQ-1800	17.0	18.5
TQ-1800BA	17.5	19.1
TQ-1800H	17.8	19.4
TQ-1800HBA	17.5	19.1



**TQ-800H** Toast Qwik®  
Horizontal Conveyor Toaster

**OPTIONS** (available at time of purchase only, excludes TQ-10)

<b>TQ-PWR-A</b>	Automatic power save mode (Switches to power save mode after 30 minutes of inactivity)	<b>No Charge</b>
-----------------	---	------------------

**ACCESSORIES** (available for purchase at any time)

<b>TQRAMP</b>	Extended feed guide (Add 76 mm) (excluding TQ-1800 models)	<b>\$101</b>
<b>TQ2-SECURITY</b>	Control cover and bracket (excluding TQ-1800 models)	<b>94</b>



**TQ-800** with  
**TQ2-SECURITY**  
accessory security  
control cover





## Toast King® Conveyor Toasters

Designed for mid to high volume and constant flow applications, Hatco's proven reliability and performance makes the Toast King Toasters the workhorse of your operation. These toasters use conveyor speed, not temperature, to determine toast color.

- Toasts a variety of bread products
- Stainless steel construction for years of trouble-free service
- Power saving thermostat for energy savings during non-peak times
- Manual advance and speed control
- Fully insulated for cooler operation
- Toast storage area keeps bread warm and dry
- Capacity of 720-1500 slices per hour
- Three basket access for fast loading
- Top venting keeps heat away from the operator



TK-72



TK-135B

### VERTICAL CONVEYOR TOASTERS

Model	Dimensions* W x D x H	Capacity/ Minute†	Basket Size	kW	Voltage	Ship Weight	List Price
<b>Bread and Buns</b>							
TK-72‡	464 x 448 x 845 mm	12 slices	254 W x 117 H mm	4.0	220, 240	33 kg	\$3951
TK-100‡	578 x 448 x 845 mm	16 slices	368 W x 117 H mm	5.0	220, 240	40 kg	4224
<b>Buns Only</b>							
TK-135B‡	578 x 448 x 845 mm	22 slices	368 W x 117 H mm	4.3	220, 240	40 kg	4224
<b>3-Part Buns</b>							
TK-155B	578 x 448 x 845 mm	25 slices	368 W x 117 H mm	5.0	220, 240	40 kg	4452

\*Width includes 19 mm for manual advance knob. Depth includes tray extension of 89 mm.

† Toasting capacity may vary by product. Toasting of coated products not recommended.

‡ CE Mark available, add \$50.

#### All Vertical Conveyor Models Feature:

Max. Product Thickness: 32 mm.

Cord Location: 1219 mm Cord – Back of unit, lower left side.

#### OPTIONS (available at time of purchase only)

TK-SECURITY Control cover, bracket, mounting hardware and fuse cover **\$179**

#### ACCESSORIES (available for purchase at any time)

4"LEGS 102 mm adjustable legs (4) **\$47**

#### TK TOASTER AMP RATINGS

Model	220V/1 Ø	240V/1 Ø
	50 or 60 Hz	50 or 60 Hz
TK-72	18.4	18.4
TK-100	22.9	21.0
TK-135B	19.7	18.1
TK-155B	22.8	20.9

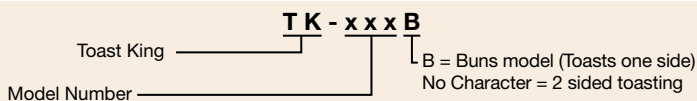

## High Watt Conveyor Toasters

Hatco High Watt Conveyor Toasters toast high moisture content bread products to a rich golden color. All models feature metal sheathed heating elements and most include cord and plug. Toast King toasters are shipped with speed control and manual advance.

- Toasts a variety of high moisture content bread products
- Full insulation for cooler operation
- Multiple metal sheathed toasting elements

- Toast storage area keeps bread warm and dry
- Capacity of 240 to 1080 slices per hour



TQ-805



TK-105

Toasters

### HIGH WATT CONVEYOR TOASTERS

Model†	Dimensions W x D x H	kW	Voltage Single Phase	Hz	Capacity/ Minute¹	Basket Size	Ship Weight	List Price
TQ-15	368 x 451 x 349 mm	2.2	220, 240	50	4 slices	—	19 kg	<b>\$1580</b>
TQ-405	368 x 451 x 378 mm•	2.3	220, 240	50	6 slices	—	22 kg	<b>2407</b>
TQ-805	368 x 578 x 422 mm*	3.6	240	50	12 slices	—	24 kg	<b>2960</b>
<b>Includes Manual Advance and Speed Control</b>								
TK-75	445 x 448 x 838 mm•	4.6	220, 240	50	12 slices	254 W x 117 H mm	35 kg	<b>\$4573</b>
TK-105	559 x 448 x 838 mm•	7.5	220, 240	50	18 slices	368 W x 117 H mm	40 kg	<b>4758</b>

† CE Mark available, add \$50 on TQ-405, TQ-805, and TK-105.

TQ-15 and TK-75 prices include CE (cannot be ordered without CE).

• Tray extends 165 mm rear for TQ-405 and TQ-805, and 89 mm front for TK-75 and TK-105.

† Toasting capacity may vary by product. Toasting of coated products not recommended.

#### All High Watt Models Feature:

Max. Product Size: TQ-405, TQ-805: 244 W x 44 H mm.

Max. Product Thickness: TK-75, TK-105: 32 mm.

Cord Location: TQ Models: Lower right corner on back of unit.

TK Models: Lower left side on back of unit.

### ACCESSORIES (available for purchase at any time)

4" LEGS	102 mm adjustable legs (4) (TK models only)	<b>\$47</b>
TQRAMP	Extends feed guide 76 mm longer (TQ models only)	<b>101</b>

TQ - x x x

Toast-Qwik ———— Model Number

TK - x x x

Toast King ———— Model Number

# Induction Equipment

*Cafeterias • Buffets*  
*Supermarkets & Delis • Restaurants & Cafés*  
*Clubs & Bars*



**IRNG-PC1-36** in standard finishes *pg. 160*



**IRNG-PB1-36** in standard finishes *pg. 161*

## Rapide Cuisine® Countertop High-Powered/Heavy-Duty Induction Ranges

Hatco's Rapide Cuisine® High-Powered/Heavy-Duty Induction Range offers industry leading features and true back of house power in a commercial kitchen proof package.

The unit features our Magnetic Power System (MPS) to deliver the highest power in its class! It has User Programmable Presets (UPP) for repeat menu items and a food temperature probe for more accurate cooking, plus a timer, high resolution color display and convenient power and temperature modes.

- Commercial kitchen ready. Heavy gauge stainless steel housing with side impact protection for the top
- Four surface temperature sensors offer the most accurate control in its class
- Culinary equivalent of up to 31,000 BTUs gas
- High resolution TFT (thin film transistor) display instantly advises the operator of precise power (1 to 100), temperature (°C in one degree increments) and time control (30 seconds to 10 hours)
- 3-stage programming mode so the operator can create preset programs for consistent and labor-saving cooking cycles
- Includes a grease filter and features conformal coated boards
- Easy to use color-coded selectable functions
- Large adaptive control for precise, fine control (slow turns) to spanning the full range in a single twist (fast turns)
- Pan Sense Technology (PST) activates the unit only when a suitable pan is placed on top
- Patterned, glass-ceramic top that is durable, easy to clean and helps scratches from heavy use appear less noticeable
- Easy to clean, fully-sealed top, stops grease or moisture from penetrating the unit, even if the top gets broken
- Automatic shut-off to prevent overheating
- Withstands high ambient kitchen temperatures (up to 51°C)
- USB port for downloading updates or adding Modes from our web site
- 1800 mm cord with plug



IRNG-PC1-36

Close up of patterned black glass-ceramic top - helps prevent noticeable scratches due to heavy use

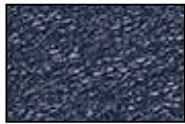

Includes a food temperature probe which facilitates highly accurate cooking

Induction

### COUNTERTOP HIGH-POWERED/HEAVY-DUTY INDUCTION RANGE

Model	Dimensions W x D x H	Voltage Single Phase Only	Watts	Ship Weight <sup>†</sup>	List Price
IRNG-PC1-36	352 mm x 471 mm x 94 mm	220-230-240	3300-3600	10 kg	\$1839

<sup>†</sup>Shipping weights are approximate.

**All Countertop High-Powered/Heavy-Duty Models Feature:**  
**Models Shipped with:** 1800 mm cord and plug (includes temperature probe).  
**Cord Location:** Rear left bottom base corner.

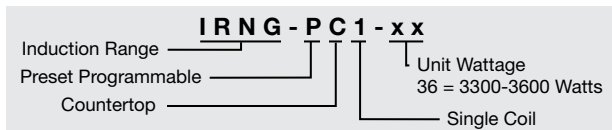



## Rapide Cuisine® Drop-In High-Powered/Heavy-Duty Induction Ranges

Hatco's Rapide Cuisine® Drop-In High-Powered/Heavy-Duty Induction Range offers industry-leading features and true back-of-house power in a commercial kitchen-proof package.

The unit can be mounted flush or near flush with the optional trim ring. It features our Magnetic Power System (MPS) to deliver the highest power in its class! It has User Programmable Presets (UPP) for repeat menu items and a food temperature probe for more accurate cooking, plus a timer, high resolution color display and convenient power and temperature modes.

- Four surface temperature sensors offer the most accurate control in its class
- Culinary equivalent of up to 31,000 BTUs gas
- High resolution TFT (thin film transistor) display instantly advises the operator of precise power (1 to 100), temperature (°C in one degree increments) and time control (30 seconds to 10 hours)
- 3-stage programming mode so the operator can create preset programs for consistent and labor-saving cooking cycles
- Includes a grease filter and conformal-coated boards
- Easy to use color-coded selectable functions
- Large adaptive control for precise, fine control (slow turns) to spanning the full range in a single twist (fast turns)
- Pan Sense Technology (PST) activates the unit only when a suitable pan is placed on top
- Patterned, glass-ceramic top that is durable, easy to clean and helps scratches from heavy use appear less noticeable
- Easy to clean, fully-sealed top stops grease or moisture from penetrating the unit, even if the top gets broken
- Automatic shut-off to safely prevent overheating
- Withstands high ambient kitchen temperatures (up to 51°C)
- USB port for downloading updates or adding Modes from our website
- Includes a remote control panel and cord
- 1800 mm cord with plug

Close up of patterned black glass-ceramic top – helps prevent noticeable scratches due to heavy use



Includes a food temperature probe which facilitates highly accurate cooking

**IRNG-PB1-36**  
shown in the standard finish

### HIGH-POWERED/HEAVY-DUTY DROP-IN INDUCTION RANGE

Model	Dimensions W x D x H	Voltage Single Phase	Watts	Ship Weight†	List Price
<b>IRNG-PB1-36</b>	343 mm x 368 mm x 91 mm	220-230-240	3300-3600	10 kg	<b>\$1940</b>

†Shipping weights are approximate.

**All Drop-In High-Power/Heavy-Duty Models Feature:**

**Models Shipped with:** 1300 mm cables from the base unit to the control panel and a 1800 mm cord and plug (includes temperature probe).

**Cord Location:** Rear right bottom base corner.

### ACCESSORY (available at any time)

**Holds unit nearly flush on the counter (for use where chair-step routing of a countertop material is not possible, but a flush mount look is desired) –**

**TRIM-PB1-36** Stainless Steel Trim Ring for IRNG-PB1-36 **\$51**



Induction

# Light Cooking Equipment

*Supermarkets & Delis • Restaurants & Cafés  
Clubs & Bars • Concessions*

**NEW**



**SNACK-2** with accessory Chelky plate *pg. 163*



**SAL-1** with accessory food pan *pg. 164*



**TF-4619** in standard *Designer Black* *pg. 165*



**TFW-461R** with accessory food pan and in  
optional *Designer Warm Red* *pg. 165*



## Electric Salamander

Hatco's Electric Salamander gives you versatility in the kitchen with the capability to cook, grill, reheat and keep foods hot. The plate detection feature activates the instant-on heating elements automatically when a food plate comes into contact with the plate detection bar.

- Ready to use in just eight seconds
- Three independently-controlled Instant-On heating elements provide the benefits of on-demand cooking and energy conservation
- Adjustable upper housing gives 4½" of vertical movement for maximum versatility
- Features high-powered infrared ribbon heating elements
- Heating elements are on only when a cook or hold cycle has been activated, eliminating residual heat in the kitchen environment
- The HOLD function has eight programmable heat levels - ideal for keeping food hot or for reheating food
- Features a flat, touch control panel and stainless steel construction



### ELECTRIC SALAMANDER

Model	Dimensions W x D x H*	Cooking Area W x D	Voltage	Hz	Watts	Ship Weight	List Price†
SAL-1	577 x 552 x 606 mm	555 x 349 mm	240/415	5060/60	4500	65 kg	\$5663

\* Height includes 102 mm legs. Add 51 mm to depth for wall mounted units.  
 † CE Mark available at no charge.

**The Electric Salamander Model Features:**

Models Shipped with: Cooking grate, drip pan, wall mounting hardware, 102 mm adjustable black plastic legs and cord with no plug.  
 Power Inlet Location: Back of unit, bottom right side.

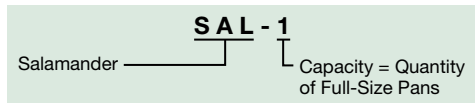

**Saves Energy,  
Saves Money,  
Protects your Reputation!**

Do your bit for Global Warming with Hatco's SAL-1. The Hatco Electric Salamander's elements are ready for use in just eight seconds. How does that work? Mounted on the back wall of the Salamander is a "plate detection" switch that keeps the unit from turning on unless a plate or pan is put underneath, against this bar. That means the elements are only on when they need to be. Most kitchens have every piece of equipment on all day, firing out heat and constantly using energy. And even in power save mode, most equipment is never fully off. Not the Electric Salamander, it's 100% off when not in use, saving money, energy and the environment.





## Thermo-Finisher® Food Finishers

Finish foods quickly with the Hatco Thermo-Finisher. Perfect for finishing foods like French onion soup or nachos; toasting buns and bread; and thermalizing frozen products like pizza, pre-cooked chicken patties and frozen entrees. Easy to use and program, it works in less than half the time of conventional methods.

- Quick-heating infrared ribbon element with special microprocessor allows five programs to be preset for time and temperature
- Standby mode saves energy, and the exclusive Instant-On feature assures that the unit is ready to use, with no warm-up time needed
- Quick and easy for any staff member to operate, with the touch of one preprogrammed button, assuring a consistent product



TF-4619 with accessory food pan



TF-461R with accessory food pan

### FOOD FINISHERS

Model†	Elements Upper/Lower	Dimensions W x D x H	Heated Cavity Opening W x D x H	Watts		Phase	Ship Weight	List Price	
				220V	380V			220V	380V
TF-1919	1 Upper/1 Lower	514 x 699 x 432 mm	330 x 457 x 162 mm	4201	4513	1	39 kg	\$4854	\$5004
TF-4619	4 Upper/1 Lower	514 x 699 x 432 mm	330 x 457 x 162 mm	–	6588▼	3	41 kg	5302	5527
TFW-461R*	4 Upper/1 Lower	648 x 530 x 470 mm	457 x 330 x 162 mm	6992	–	1	41 kg	5543	–

† CE Mark not available.

▼ No plug.

• Height includes 102 mm legs.

**All Food Finisher Models Feature:**

Cord Location: 1829 mm cord with plug, left side of back near center.

#### OPTIONS (available at time of purchase only)

Designer Color Side Panels – Non-standard colors are non-returnable – Black standard –

RED	Warm Red	No Charge
-----	----------	-----------

#### ACCESSORIES (available for purchase at any time)

ALUM PAN	457 W x 330 D mm Half-Size Sheet Pan	\$ 28
TF-10SAUTE	254 mm Aluminum Saute Pan with tapered sides	119

**FOOD PANS AND TRIVETS – PAGE 178**  
**COLORS AND FINISHES – INSIDE BACK COVER**

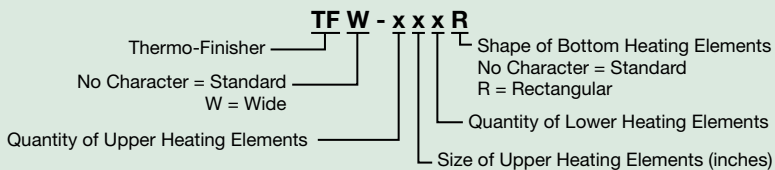

Light Cooking  
Equipment

# Water Heaters

*Cafeterias • Convenience Stores  
Supermarkets & Delis • Restaurants & Cafés  
Clubs & Bars • Catering • Concessions*



**3CS-9B** with optional temperature monitor *pg. 167*



**FR-9B** *pg. 168*



**FR-9** *pg. 168*



**C-24** *pg. 169*



**C-27** *pg. 169*



**S-57** with optional Stainless Steel body and base, and accessory Stainless Steel legs *pg. 171*



### 3CS Sanitizing Sink Heaters

Maintaining a continuous supply of sanitizing rinse water without taking up valuable space, the 3CS makes manual warewashing faster and more convenient. Drain may be plumbed to open-sight waste drain. A special 3CS Sink Heater is available for shipboard use under military spec. (Mil-H-43895B). Consult factory for prices.

- Stainless steel front, powdercoated silver-gray hammertone body and convenient side drain
- Equipped with an Energy Cut-Off (ECO) for built-in protection against higher than normal water temperature
- On/Off toggle switch with indicator light to indicate power status, and a red light to indicate the need to refill and reset the unit
- Meets NSF standard of 82°C for dish sanitizing



3CS-9 with optional temperature monitor

#### SANITIZING SINK HEATERS

Model	kW	Sink Area	Phase	Ship Weight	List Price
3CS-3 <sup>†</sup>	3.0	381 mm Sq. or less	1	11 kg	\$2236
3CS-4 <sup>†</sup>	4.5	406-457 mm Sq.	1	11 kg	2256
3CS-6 <sup>†</sup>	6.0	483-533 mm Sq.	1	12 kg	2301
3CS-9 <sup>†</sup>	9.0	533-635 mm Sq.	1	12 kg	2381
3CS-3B <sup>‡</sup>	3.0	381 mm Sq. or less	Balanced 3	14 kg	2551
3CS-4B	4.5	406-457 mm Sq.	Balanced 3	14 kg	2551
3CS-6B <sup>‡</sup>	6.0	483-533 mm Sq.	Balanced 3	14 kg	2551
3CS-9B <sup>‡</sup>	9.0	533-635 mm Sq.	Balanced 3	15 kg	2551

<sup>†</sup> 240V available with CE Mark, add \$60.

<sup>‡</sup> 380V and 415V available with CE Mark, add \$60.

#### All Sink Heater Models Feature:

Voltage: 240, single phase and 240, 380 (no 4kW) or 415 (no 4kW), three-phase.

480 three-phase available (add \$112).

Dimensions: 3CS-3, -4, -6, -9: 171 W x 429 D x 321 H mm.

3CS-9 480V: 203 W x 435 D x 321 H mm.

3CS-3B, -4B, -6B, -9B: 203 W x 435 D x 321 H mm.

Models Shipped with: Stainless steel front, silver gray hammertone body and black base.

#### WATER QUALITY REQUIREMENTS – PAGE 179

#### OPTIONS (available at time of purchase only)

SSBB	All Stainless Steel Body and Base	\$ 103
TEMP MON <sup>▲</sup>	Temperature Monitor (built-in)	107
TEMP LIGHT <sup>▲</sup>	Temperature Light	82
FR-SECURITY	Security Package (Torx <sup>®</sup> Screws and Control Cover)	158
3CS-480V	480 Volt	112

#### ACCESSORIES (available for purchase at any time)

FR-FLUSH	Flush Hose, Stopper and Adapter	\$68
----------	---------------------------------	------

<sup>▲</sup> Specify either monitor or light, not both.

#### SIZING INFORMATION

For a Sink Heater: 2,2 watts per square cm of vessel top.

3CS Sink Heaters are sized based on 60°C supply water with a 30 minute preheat period to reach the sanitizing temperature. Sink Heaters are mounted into the third compartment sink with standard plumbing fittings provided. Two 51 mm diameter holes are required for these fittings and a full size template is provided to locate holes in the sink. The 3CS Sink Heater is easily attached to the plumbing fittings with self-contained unions.

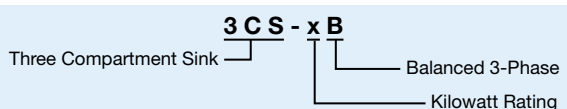
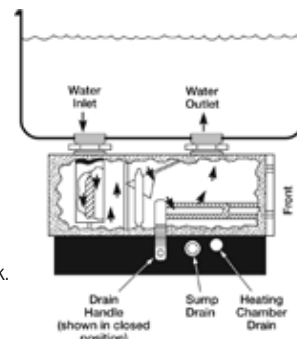

## FR Food Rethernalizer/ Bain-Marie Heaters

The Hatco FR is a Bain-Marie or food reconstitutor to heat or hold foods at safe temperatures between 60°C and 88°C). All models are shipped factory assembled, pre-wired and include standard 51 mm stainless steel plumbing fittings for mounting into a holding tank. Drain may be plumbed to open-sight waste drain.

- Equipped with an Energy Cut-Off (ECO) for built-in protection against higher than normal water temperature
- Stainless steel tank with five year limited warranty
- Optional low-water cut-off (LWCO) available to prevent element burn out from low water conditions
- Separate sump and heating compartment drains for cleaning and sanitizing



FR-9

### FOOD RETHERMALIZER/BAIN-MARIE HEATERS

Model	kW	Phase	Ship Weight	List Price <sup>†</sup>
FR-3	3.0	1	11 kg	\$2056
FR-4	4.5	1	11 kg	2076
FR-6	6.0	1	13 kg	2291
FR-9	9.0	1	13 kg	2356
FR-3B	3.0	Balanced 3	14 kg	2516
FR-4B	4.5	Balanced 3	15 kg	2516
FR-6B	6.0	Balanced 3	14 kg	2516
FR-9B	9.0	Balanced 3	14 kg	2516

<sup>†</sup> CE Mark available, add \$60. Requires Low-Water Cut-Off, add \$177. (excludes FR-4, FR-4B and FR-9)

#### All Food Rethernalizer Models Feature:

Voltage: 240, single phase and 240, 380-415 (no 4kW) or 415 (no 4kW), three-phase. 480 three-phase available (add \$112).

Dimensions: FR-3, -4, -6, -9: 171 W x 429 D x 312 H mm.

FR models with 480V and Low Water Cut-Off: 203 W x 435 D x 312 H mm.

FR-3B, -4B, -6B, -9B: 203 W x 435 D x 312 H mm.

Models Shipped with: Stainless steel front, silver gray hammertone body and black base.

### WATER QUALITY REQUIREMENTS – PAGE 179

#### OPTIONS (available at time of purchase only)

SSBB	All Stainless Steel Body and Base	\$ 103
W/LW	Low-Water Cut-Off (required on CE models)	177
FR-SECURITY	Security Package (Torx® Screws and Control Cover)	158
FR-480V	480 Volt	112

#### ACCESSORIES (available for purchase at any time)

FR-FLUSH	Flush Hose, Stopper and Adapter	\$68
----------	---------------------------------	------

#### SIZING INFORMATION

For a Bain-Marie or steam table: 0,8 watts per square cm of vessel top.

For a Food Rethernalizer: 2,2 watts per square cm of vessel top.

Use one FR for a Bain-Marie up to 1829 mm long. Units over 1829 mm require a minimum of two FRs. (Tank Baffle provided by installer.)

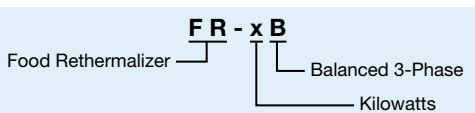
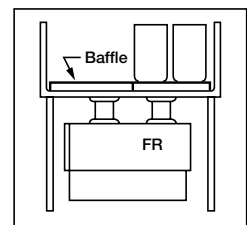





## Compact Electric Booster Water Heaters

Compact models provide all the 82°C final rinse water to sanitize and flash-dry dishes and flatware. Models include stainless steel front panel, silver gray hammertone body, black base and standard 152 mm legs. Slide brackets for mounting under a dishtable are available. The Castone® lined tank is standard on all models and has a 23-liter capacity.

- The Compact Electric Booster is easy to install next to a dishwasher to save space, either on 152 mm plastic legs or with slide brackets
- All models include a Castone® lined tank with a 10-year limited warranty, and fiberglass insulation to minimize heat loss
- Swing-away front panels with low-water cut-off (LWCO), control fuses and transformer allow quick access to probes and elements, for easier serviceability

**NOTE:** Single phase is uncommon in heaters 24kW and larger and are NOT returnable.



C-18 with optional Stainless Steel body and base



C-45

### COMPACT ELECTRIC BOOSTER WATER HEATERS

Model*	kW	240V		380 or 415V†	480V	Ship Weight	List Price		
		Single Ph	Three Ph				240V	380 or 415V† or 480V	
<b>Small</b>									
C-4	4	⊕	—	—	▼	52 kg	\$2971	\$2971	
C-5	5	—	—	—	▼	52 kg	3016	3016	
C-6	6	—	—	—	—	54 kg	3071	3071	
C-7	7	—	—	—	—	54 kg	3111	3111	
C-9	9	—	—	—	—	54 kg	3146	3146	
C-12	12	—	—	—	—	54 kg	3331	3331	
C-13	13.5	—	—	■	—	55 kg	3351	3351	
C-15	15	—	—	—	—	55 kg	3391	3391	
C-17	17.25	—	—	—	—	54 kg	3416	—	
C-18	18	—	—	—	—	55 kg	3441	3441	
<b>Large</b>									
C-24	24	—	—	—	—	64 kg	\$4586	\$4586	
C-27	27	—	—	—	—	64 kg	4651	4651	
C-30	30	—	—	—	—	65 kg	4696	4696	
C-36	36	—	—	—	—	64 kg	4916	4836	
C-39	39	—	—	—	—	65 kg	5001	4916	
C-45	45	—	—	—	—	64 kg	5566	5476	
C-54	54	—	—	—	▲	65 kg	5731	5636	
C-57	57	—	—	—	—	65 kg	5831	5731	

† CE Mark available on models 6 through 36kW, 380-400 volts or 400-415 volts, 3-phase only, add \$105.

• Only 6, 7, & 9kW models can be field converted to single phase (units are shipped 3-phase open delta). Larger branch circuit required than for balanced 3-phase of equal kW. (Balanced 3-phase available in 4-6 & 9kW models, consult factory.) 240 volt only.

◦ Not available in 240V single phase.

▼ 480V available in single phase only. Consult factory if Balanced 3 Ph is required.

■ 380V not available.

▲ 380V has 49kW.

#### All Compact Electric Booster Models Feature:

Voltage: 240, single phase. 240, 380, 415 or 480, three phase.

Dimensions: Models C-4 through C-18: 330 W x 527 D x 502 H mm.

Add 133 mm to depth for temperature/pressure relief valve. Height includes legs.

Models C-24 through C-57: 457 W x 610 D x 457 H mm.

Add 165 mm to depth for temperature/pressure relief valve. Height includes legs.

Models Shipped with: Castone® tank, low-water cut-off (LWCO), temperature/pressure relief valve, pressure reducing valve, two temperature/pressure gauges, indicator light and on/off switch.

NOTE: Pages 174 to 176 for sizing information.

NOTE: Consult product specification sheet for proper breaker size. Verify amperage load for Booster Heaters 24kW through 57kW in single phase.

Because of excessively high amps and since these units are NOT field convertible to any other voltage or phase, written confirmation is required before processing can begin.

#### OPTIONS AND ACCESSORIES – PAGE 170

#### LOW-TEMP DISHWASHERS – SEE LOW-TEMP SIZING DATA ON PAGE 177

#### WATER QUALITY REQUIREMENTS – PAGE 179

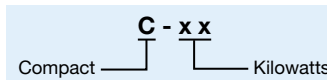



C-27 with accessory slide brackets

**OPTIONS** (available at time of purchase only)

<b>SSBB</b>	Stainless Steel Body and Base	<b>No Charge</b>
<b>C-SECURITY</b>	Security Package (Torx® Screws and Control Cover)	<b>\$158</b>

**ACCESSORIES** (available for purchase at any time)

<b>FLOORMOUNT</b>	Additional Stainless Steel Floor Mounting Leg Assembly	<b>\$290</b>
<b>WATERTREAT</b>	Blended Phosphate Water Treatment System - not for potable water use (Page 173 for illustration)	<b>743</b>
<b>SHOCK</b>	Shock Absorber reduces water hammer	<b>106</b>
<b>BPRV</b>	Back Pressure Relief Valve	<b>61</b>
<b>PRVB</b>	Additional Brass Pressure Reducing Valve with By-Pass	<b>162</b>
<b>SSA-LEGS</b>	Additional Stainless Steel Adjustable Legs (152-178 mm)	<b>186</b>
<b>BOOSTERBRKT</b>	Additional Slide Brackets	<b>66</b>

NOTE: 152 mm plastic adjustable legs 152-178 mm standard, specify slide brackets if required. Description of accessories is shown on page 173.

**WATER TEMPERATURE RECOVERY TABLE**

Compact Model	22°C Rise	39°C Rise	Compact Model	22°C Rise	39°C Rise
<b>C-4</b>	151 lph	87 lph	<b>C-18</b>	685 lph	390 lph
<b>C-5</b>	189 lph	110 lph	<b>C-24</b>	912 lph	522 lph
<b>C-6</b>	227 lph	129 lph	<b>C-27</b>	1026 lph	587 lph
<b>C-7</b>	265 lph	151 lph	<b>C-30</b>	1139 lph	651 lph
<b>C-9</b>	341 lph	197 lph	<b>C-36</b>	1367 lph	780 lph
<b>C-12</b>	454 lph	261 lph	<b>C-39</b>	1480 lph	848 lph
<b>C-13</b>	511 lph	292 lph	<b>C-45</b>	1711 lph	977 lph
<b>C-15</b>	572 lph	326 lph	<b>C-54</b>	2052 lph	1174 lph
<b>C-17</b>	655 lph	375 lph	<b>C-57</b>	2169 lph	1234 lph

NOTE: lph is "liters per hour".



## Imperial Electric Booster Water Heaters

Imperial Booster Water Heaters combine quality construction and rugged dependability to provide up to 2169 lph of 82°C sanitizing rinse water. Models include stainless steel front panel, silver gray hammertone body, black base, standard 152 mm legs, Castone® lined tank and have a 61-liter capacity.

- All models include a Castone® lined tank with a 10-year limited warranty
- Features temperature/pressure relief valve, two temperature gauges, a high-temperature limit control, pilot indicator light, On/Off switch and a low-water cut-off (LWCO) to prevent element burnout due to low water conditions
- Built-in heat trap and fiberglass insulation minimizes heat loss
- Stainless steel front panel and powdercoated silver-gray hammertone body is standard on all Imperial models

**NOTE:** Single phase is uncommon in heaters 24kW and larger and are NOT returnable.



S-54

### IMPERIAL ELECTRIC BOOSTER WATER HEATERS

Model*	kW	240V Single Ph	240V Three Ph	380 or 415V† Three Ph	480V Three Ph	Ship Weight	List Prices	
							240V	380, 415 or 480V
<b>Small</b>								
S-6	6					91 kg	\$4311	\$4311
S-7	7					91 kg	4371	4371
S-9	9					91 kg	4406	4406
S-12	12					91 kg	4651	4651
S-13	13.5					91 kg	4671	4671
S-15	15					91 kg	4696	4696
S-17	17.25	—		—		91 kg	4726	—
S-18	18					91 kg	4756	4756
<b>Large w/Step Loading</b>								
S-24	24					97 kg	\$5436	\$5436
S-27	27					97 kg	5481	5481
S-30	30					97 kg	5551	5551
S-36	36					97 kg	5951	5916
S-39	39	—		—		97 kg	6026	5986
S-40	40.5					102 kg	6221	6176
S-45	45	—				102 kg	6321	6271
S-54	54	—				102 kg	6341	6286
S-57	57					102 kg	6451	6391

† CE Mark available on models 6 through 36kW, 380-400 volts or 400-415 volts, 3-phase only, add \$105.

• Only 6, 7 & 9kW models can be field converted to single phase (units are shipped 3-phase open delta). Larger branch circuit required than for balanced 3-phase of equal kW. (Balanced 3-phase available in 6 & 9kW models, consult factory.) 208 and 240V only.

**All Electric Booster Models Feature:**

**Voltage:** 240, single phase. 240, 380, 415 or 480, three phase.

**Dimensions:** 600 W x 578 D x 791 H mm. Add 127 mm to depth for temperature/pressure relief valve. Height includes legs.

**Models Shipped with:** Castone® lined tank, low-water cut-off (LWCO), temperature/pressure relief valve, pressure reducing valve, two temperature/pressure gauges, indicator light and on/off switch.

**NOTE:** Pages 174 to 176 for sizing information.

**NOTE:** Consult product specification sheet for proper breaker size. Verify amperage load for Booster Heaters 24kW through 57kW in single phase. Because of excessively high amps and since these units are NOT field convertible to any other voltage or phase, written confirmation is required before processing can begin.

**OPTIONS AND ACCESSORIES – PAGE 172**

**LOW-TEMP DISHWASHERS – SEE LOW-TEMP SIZING DATA ON PAGE 177**

**WATER QUALITY REQUIREMENTS – PAGE 179**

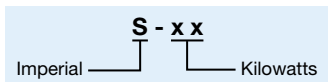



S-57 with optional stainless steel body and base, and accessory adjustable stainless steel legs

### OPTIONS (available at time of purchase only)

<b>SSBB</b>	Stainless Steel Body and Base	<b>No Charge</b>
<b>S-SECURITY</b>	Security Package (Torx® Screws and Control Cover)	<b>\$158</b>

### ACCESSORIES (available for purchase at any time)

<b>FLOORMOUNT</b>	Additional Stainless Steel Floor Mounting Leg Assembly	<b>\$290</b>
<b>WATERTREAT</b>	Blended Phosphate Water Treatment System - not for potable water use (Page 173 for illustration)	<b>743</b>
<b>SHOCK</b>	Shock Absorber reduces water hammer	<b>106</b>
<b>BPRV</b>	Back Pressure Relief Valve	<b>61</b>
<b>PRVB</b>	Additional Brass Pressure Reducing Valve with By-Pass	<b>162</b>
<b>SSA-LEGS</b>	Additional Stainless Steel Adjustable Legs (152-178 mm)	<b>186</b>

NOTE: 152 mm plastic adjustable legs 152-178 mm standard. Description of accessories is shown on page 173. Only leg mounting available.

### WATER TEMPERATURE RECOVERY TABLE

Imperial Model	22°C Rise	39°C Rise	Imperial Model	22°C Rise	39°C Rise
<b>S-6</b>	227 lph	129 lph	<b>S-24</b>	912 lph	522 lph
<b>S-7</b>	265 lph	151 lph	<b>S-27</b>	1026 lph	587 lph
<b>S-9</b>	341 lph	197 lph	<b>S-30</b>	1139 lph	651 lph
<b>S-12</b>	454 lph	261 lph	<b>S-36</b>	1367 lph	780 lph
<b>S-13</b>	511 lph	292 lph	<b>S-39</b>	1480 lph	848 lph
<b>S-15</b>	572 lph	326 lph	<b>S-40</b>	1541 lph	878 lph
<b>S-17</b>	655 lph	375 lph	<b>S-45</b>	1711 lph	977 lph
<b>S-18</b>	685 lph	390 lph	<b>S-54</b>	2052 lph	1174 lph
			<b>S-57</b>	2169 lph	1234 lph

NOTE: lph is "liters per hour".



## Booster Installation

### SINGLE BOOSTER INSTALLATION

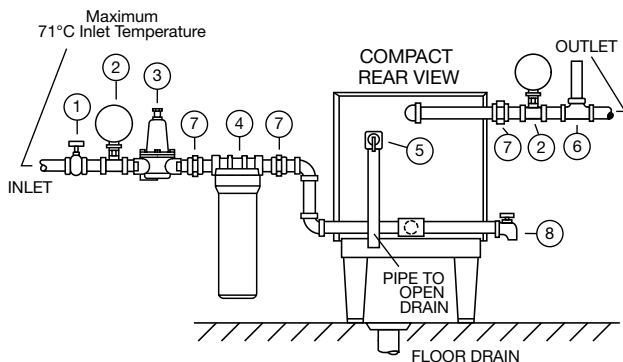

### DUAL BOOSTER INSTALLATION

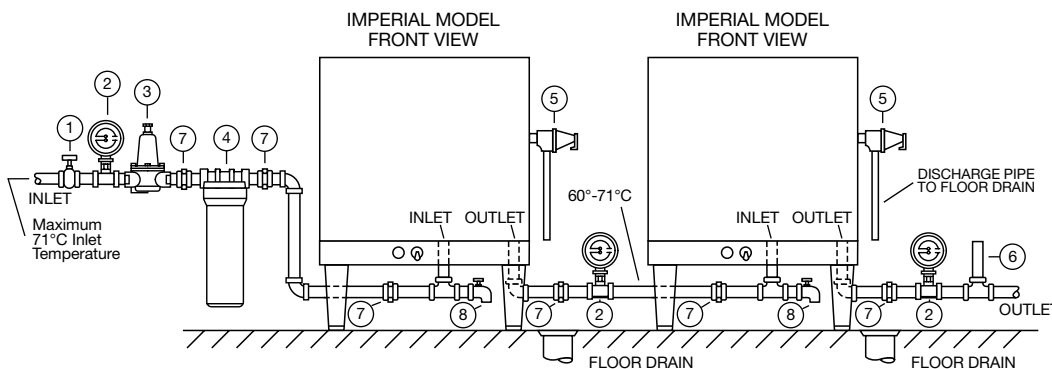

- ① 3/4" Gate or Ball Valve\*    ② Temperature/Pressure Gauge    ③ Pressure Reducing Valve with By-Pass    ④ Blended Phosphate Water Treatment System
- ⑤ Relief Valve (must have discharge pipe to floor drain)    ⑥ Shock Absorber    ⑦ Union\*    ⑧ Drain Pipe Valve\*    \*Supplied by installer

CONSULT LOCAL CODES

**NOTE:** The differential temperature between outlet and inlet temperatures should never be less than 11°C.

**NOTE:** Thermostat calibration, or adjustment, must be performed at time of installation and is excluded from warranty coverage. Thermostat adjustments for Low-Temp applications are the responsibility of the installer.

## BOOSTER WATER HEATER ACCESSORIES

### Back Pressure Relief Valve –

This valve relieves pressure when unit is heating, on models that a check valve is required on the supply line. To be plumbed over an open site drain.



### Pressure Reducing Valve –

This valve, with built-in by-pass, should be installed in the supply line to the booster to regulate and stabilize flow pressure to 138kPa.



**Stainless Steel Adjustable Legs –** Adjustable from 152 to 178 mm. Clean appearance and heavy-duty for long wear.



### Floor Mounting Hardware –

Adjustable from 152 to 178 mm. Corrosion-resistant stainless steel legs for deck mounting.



### Blended Phosphate Water Treatment System –

Minimizes scale formation and increases unit efficiency. Recommended for Electric Boosters (Not for potable water use).



### Shock Absorber –

Recommended between the booster and the dishwasher, on all installations, to prevent water hammer. Standard with Powermite® units.

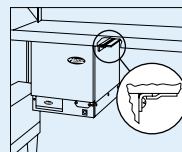

**Slide Bracket –** For mounting the booster heater under a dishtable (available on small and large Compact models only).





## Booster Heater Sizing Chart

Dishwasher Model Number	Electric Compact Booster Temperature Rise		Electric Imperial Booster Temperature Rise	
	22°C	39°C	22°C	39°C
<b>ADAMATION</b>				
CSL-1390, CA-2, CA-3, CA-4, SLAP 44	C-39	(2)C-36	S-39	(2)S-36
CA, CA-1	C-54	(2)C-45	S-54	(2)S-45
<b>ALVEY</b>				
FLC-10, SL-2S			S-6	S-9
FLC-12, CL-1, CL-1 Turntable, SA-5A			S-7	S-12
FL-2S			S-9	S-13
KS-70, KS70M SB			S-9	S-15
SL-2D			S-13	S-18
FLC-36			S-15	S-27
KS-88-C			S-18	S-30
KS-70-N, KS-88-N			S-39	(2)S-40
<b>AMERICAN DISH SERVICE</b>				
HT-25	C-7	C-12	S-7	S-12
ACD-44, ADC-66	C-12	C-24	S-12	S-24
<b>BLAKESLEE</b>				
UC-21A, UC-21B	C-4	C-4	S-6	S-6
UC-21	C-6	C-12	S-6	S-12
D-8	C-9	C-13	S-9	S-13
D-9	C-12	C-17	S-12	S-17
Series "R" & "F" -CC, -EE, -LL, -MM, -LLL, -MMM, -PCC, -PEE, -PLL, -PMM (multi-tank) with suffix "LC"	C-13	C-24	S-13	S-24
Series XF-EE, XF-LL	C-17	C-30	S-17	S-30
Series XF-LL, XF-PLL, XF-MM, XF-PMM, XF-EEE, XF-LLL, XF-MMM (Multi-tank) with suffix "LC"	C-17	C-30	S-17	S-30
DD-8	C-18	C-30	S-18	S-30
Series F-E, FA-EE, FA-PEE, FA-LL, FA-PLL, FA-MM, FA-PMM, F-EEE, FA-EEE, FA-LLL, FA-MMM, F-PE	C-30	C-54	S-30	S-54
Series R-L, R-PL, R-M, R-PM, F-L, F-PL, F-M, F-PM (single tank)	C-36	C-54	S-36	S-54
Series XF-L, XF-PL, XF-M, XF-PM (single tank)	(2)C-36		(2)S-36	
Series R-E, R-PE, XF-PEE, XF-PLL, XF-PMM, XF-EEE, XF-LLL, XF-MMM (multi-tank) FA (Flight-A-Round) and RA (Rack-A-Round) use comparable "F" listing.	C-45	(2)C-30	S-45	(2)S-30
XF-EE, XF-EE-LT (with LT suffix)	C-17	C-36	S-17	S-36
<b>CHAMPION</b>				
U-H1, UH-200, UH-200B, U-HB	C-4	C-6	S-6	S-6
UL-150	C-4	C-7	S-6	S-7
UH-150, UH-150B, UH-100, UH-100B, DHB-VS	C-5	C-9	S-6	S-9
D-H1, D-HB	C-6	C-12	S-6	S-12
D-H1T, D-HBT	C-7	C-12	S-7	S-12
44 DRWS, 66 DRPWS, 80 DRHDPWS, 70 DRFFPWS	C-9	C-13	S-9	S-13
PP-28	C-9	C-15	S-9	S-15
D-H1C, D-H1TC	C-9	C-18	S-9	S-18
DHB-VS	C-6	C-12	S-6	S-12
DL-1000, DH-1000	C-6	C-12	S-6	S-12
44 DR, 66 DRPW, 80 DRHDFW, 70 DRFFPW	C-12	C-24	S-12	S-24
66 WSPW, 44-WS, 66-WS, 64, 90FFPW, 100HDPW, 86 PW, 84, 106 PW, 120 HDPW, 110 FFPW	C-13	C-24	S-13	S-24
UC-CW6-WS	C-24	C-36	S-24	S-36
US-CW8-WS	C-24	C-39	S-24	S-39
44, 66 PW, 70FFPW, 80HDPW, 54, 76PW, 80FFPW, 90HDPW	C-24	C-45	S-24	S-45
40-KB, 40-KB-2-2, 40-KFWB, 40-KPRB, 40-KPRB-2-2, 40KPRB-2-3, 60-KB, 60-KB-2-2, 60-KFWB, 60-KFWB-2-2, 60-KPRB, 60-KPRB-2-3 64KB, 64-KB Corner, 64-KPRB, 64-KPRB Corner, 64 Modular, 86 Modular	C-30	C-54	S-30	S-54
44-KB, 44-KB Corner, 44-KPRB, 44-KPRB Corner, 54-KB, 54-KB Corner, 54-KPRB, 54-KPRB Corner, 44 Modular, 66 PW Modular, UC** Series 6' Center, UC-C4	C-36	C-57	S-36	S-57
UC-CW4	C-36	(2)C-36	S-36	(2)S-36
UC-C	C-45	(2)C-36	S-45	(2)S-36
UC**CW Series 6' Center	C-45	(2)C-39	S-45	(2)S-39
W-6-WS	C-45	(2)C-45	S-45	(2)S-40



## Booster Heater Sizing Chart

Dishwasher Model Number	Electric Compact Booster Temperature Rise		Electric Imperial Booster Temperature Rise	
	22°C	39°C	22°C	39°C
<b>CMA DISHMACHINES</b>				
AH, C, B*	C-9			
CMA-180	C-5	C-9	S-5	S-9
CMA-180T	C-9	C-13	S-9	S-13
CMA-44/66	C-24	C-36	S-24	S-36
CMA-44H with tank heater, CMA-66H	C-36	C-45	S-36	S-45
EAH/EC*, GLX/L1X/L1X16/L1C	C-4			
EST*	C-5			
EST-44/66	C-12	C-24	S-12	S-24
<b>HOBART</b>				
AM-15F	C-4	C-6	S-6	S-9
LXiC, LXiGC, LX-18C, LX-30C, LX-40C, AM-15F	C-4	C-7	S-6	S-6
LX-30, SR24, SR24H	C-4	C-7	S-6	S-7
LX-18, AM-14F, AM-15, AM-15T	C-5	C-9	S-6	S-9
WM-5C	C-6	C-9	S-6	S-9
WM-5 (Without sump heater)	C-7	C-12	S-7	S-12
AM-14T, AM-14TC	C-7	C-12	S-7	S-12
AM-14, AM-14C	C-9	C-12	S-9	S-12
AM-12, AM-12C*	C-9	C-12	S-9	S-12
UW-50			S-15	S-24
OR Opti-RinSe C44A, CRS-66A, CCS-66A, CPW-80A, C54A, CRS-76A, CCS-76A, CPW-90A, C64A, CRS-86A, CCS-86A, CPW-100A, C88A, CRS-110A, CCS-110A, CPW-124A	C-15	C-27	S-15	S-27
C-54A, CRS-76A, CPW-90A, CCS-76A	C-39	(2)C-36	S-39	(2)S-36
C-44A, CRS-66A, CCS-66A, CPW-80A, C-64A, CRS-86A, CCS-86A, CPW-100A	C-30	C-54	S-30	S-54
C-88A, CRS-110A, CPW-124A, CCS-110A	C-36	C-54	S-36	S-54
Opti-RinSe C44AW, CRS-66AW, CCS-66AW, CPW-80AW	C-9	C-15	S-9	S-15
OR C-44AW, CRS-66AW, CPW-80AW, CCS-66AW	C-12	C-24	S-12	S-24
C-44, CRS-66, CPW-80	C-36	C-54	S-36	S-54
C-54, CRS-76, CPW-90	C-54	(2)C-39	S-54	(2)S-39
C-64W, CRS-86W, CPW-100W, C-88W, CRS-110W, CPW-124W, CCS-86W	C-24	C-36	S-24	S-36
C-64, CRS-86, CPW-100	C-45	(2)C-36	S-45	(2)S-36
FT800W, FT-900W	C-24	C-39	S-24	S-39
FT-600, FT-700	C-54	(2)C-39	S-54	(2)S-39
FT800	C-39	(2)C-39	S-39	(2)S-39
Opti-RinSe	C-36	C-57	S-36	S-57
FT800S, FT-900S	C-39	(2)C-36	S-39	(2)S-36
UTW-28, UTW-28C			S-18	S-36
FRC and FR (Fast Rack Series) use comparable "C" line listing.				
<b>INSINGER</b>				
GS 302, GS-14	C-4	C-4	S-6	S-6
45SA-5	C-9	C-18	S-9	S-18
Commander 18-5C, 18-5CH, CS-5, CS-5C, CS-5CH, CS-5H	C-6	C-12	S-6	S-12
Commander 18-5, 18-5H, Ensign 40-2	C-6	C-12	S-6	S-12
Commander 18-6, 18-6H	C-6	C-12	S-6	S-12
Commander 18-6, 18-6H (Built-In)	ABB-13.5	ABB-13.5		
Admiral 44, 66	C-15	C-27	S-15	S-27
Admiral 44-4, 66-4	C-24	C-36	S-24	S-39
Admiral 44-4, 66-4 (Built-In)	ABB-15-8	ABB-27-8		
135-20, 185-20, 250-20, 60-20, 85-20, Gallymaster & Modular	C-54		S-54	
Speeder 64, 86-3, Century (all), Super 106-2	C-24	C-45	S-24	S-45
Trac 878	C-24	C-36	S-24	S-36
Clipper (all), R106-2, Super 106-2, Trac 321, Trac 321-2/RPW	C-27	C-45	S-27	S-45
Defender-(1)	C-30	C-54	S-30	S-54
Defender	C-36	C-54	S-36	S-54
Master (all)	C-36	C-57	S-36	S-57
CA-3			S-9	S-24
DA-3			(2)S-9	(2)S-24
For outdated models, consult factory for correct booster.				

\* All cycles

\* Model AM-12 with serial no. 12-067-357 or below and model AM-12C with serial no. 12-067-537 or below require slightly larger booster than listed.

OR C Models with serial no. 85-1041605 or greater use Opti-RinSe.

■ Shaded area indicates older models prior to Opti-RinSe.



## Booster Heater Sizing Chart

Dishwasher Model Number	Electric Compact Booster Temperature Rise		Electric Imperial Booster Temperature Rise	
	22°C	39°C	22°C	39°C
<b>JACKSON</b>				
JP-24, JP-24B, JP-24F, JP-24BF	C-4	C-6	S-6	S-6
24B Series		C-4		S-6
10AB, 10APRB		C-5		S-6
44CE*, 66 CERPW	C-30	C-54	S-30	S-54
54CE, 76 CERPW	C-36	(2)C-30	S-36	(2)S-30
64CE, 86 CERPW	C-27	C-39	S-27	S-39
100	C-12	C-24	S-12	S-24
100B, 100PRB, 150B, 150PRB		C-9		S-9
150	C-12	C-18	S-12	S-18
200	C-7	C-12	S-7	S-12
200B		C-6		S-6
Tempstar, Tempstar SDS, Tempstar HH	C-6	C-12	S-6	S-12
TS-44, TS-66	C-24	C-36	S-24	S-36
AJ-44, AJ-66, AJ-80, WH-44, ES-4400, ES-6600 (ECOLAB/JACKSON)	C-24	C-45	S-24	S-45
AJ-54, AJ-76, AJ-90	C-30	C-54	S-30	S-54
AJ-64, AJ-86, AJ-100	C-24	C-39	S-24	S-39
* Model #44CE w/SN1999 or below requires larger booster than listed.				
<b>KNIGHT EQUIPMENT LTD.</b>				
KLE-112-HL	C-7	C-12	S-7	S-12
<b>MEIKO</b>				
K-44, K-66, K-80	C-24	C-36	S-24	S-36
K-54, K-76, K-90, K-64, K-86, K-100	C-24	C-45	S-24	S-45
<b>METALWASH/INTENDGE</b>				
FW4	C-12	C-18	S-12	S-18
RS-30A, RS-28L			S-15	S-24
RT-74, RT-60, RT-42B, RT-42BC			S-27	S-40
RS-2R			S-30	S-45
<b>STERO</b>				
ER-44, ER-44-10, ER-66S, ER-76S, ER-76SC	C-12	C-24	S-12	S-24
ER-64, ER-86S, ER-94S, ER-94SC	C-15	C-24	S-15	S-24
SCT-44-10-LW, SCT-44-LW, SCT-66S-LW, SCT-76S-LW, SCT-76SC-LW, SCT-90S-LW	C-12	C-24	S-12	S-24
SC-1-2-4-LW, SC-1-6-4-LW, SC-2-4-LW, SC-5-2-4-LW, SC-5-6-4-LW, SC-6-4-LW	C-24	C-45	S-24	S-45
SCT-64, SCT-86S, SCT-94S, SCT-94SC	C-24	C-39	S-24	S-39
SCT-108S, SCT-108SC, SCT-76, SCT-94SM	C-27	C-54	S-27	S-54
SC-6-4, SCT-44, SCT-44-10, SCT-66S, SCT-76S, SCT-76SC, SCT-90S	C-30	C-54	S-30	S-54
SCT-120S, SCT-120SC, SCT-120SM, SCT-150SM	C-36	C-57	S-36	S-57
STW-110, SC-1-2-7-4, SC-1-6-3-4, SC-1-6-7-4, SC-2-7-4, SC-5-2-7-4, SC-5-6-3-4, SC-5-6-7-4, SC-6-3-4, SC-6-7-4	C-39	(2)C-36	S-39	(2)S-36
SC-1-2-4, SC-1-6-4, SC-2-4, SC-5-2-4, SC-5-6-4	C-45	(2)C-36	S-45	(2)S-36
SCT-44-10-SC-1-3-4, SCT-44-10-3-4, SCT-44-SC-1-3-4, SCT-44-SC-3-4, SCT-54-SC-1-3-4, SCT-54-SC-3-4, SCT-76S-SC-3-4	C-45	(2)C-36	S-40	(2)S-36
STPC (Four tank)	C-24	C-39	S-24	S-39
STPCW (Four tank)	C-24	C-45	S-24	S-40
STPC	C-27	C-54	S-27	S-54
STPCW	C-36	(2)C-30	S-36	(2)S-30
SCBT	C-45	(2)C-36	S-40	(2)S-36
SF-1RA, SC20-1	C-7	C-12	S-7	S-12
SF-2RA, SF-2DRA, SD-2RA, SDRA, SDRA-PACK	C-12	C-18	S-12	S-18
SCT-54, SCT-76SM	C-36	C-57	S-36	S-57
SCT-76, SCT-80, SCT-94, SCT-108, SCT-120	C-45	C-57	S-45	S-57
U-31-A, U-31-AC			S-18	S-36
U-31-A2	C-45	(2)C-36	S-45	(2)S-36
STBUW-14	C-57	(2)C-54	S-57	(2)S-54
SC-2-3-4, SC-5-2-3-4	C-30	(2)C-27	S-30	(2)S-27
SC20-2	C-12	C-24	S-12	S-2
SC-2-8, SC-2-9, SC-1-2-8, SC-5-6-8, SC-6-8, SC-6-9, SC-1-6-8, SC-5-6-9, SC-5-2-9, SC-1-6-9, SC-5-2-8	C-18	C-36	S-18	S-36

This selector chart is based on 22°C and 39°C temperature rises, 138kPa flow pressure, and minimum rinse cycle timer setting in NSF listing.

All booster heaters are rated at 100% of the capacity of the dishwashers as recommended by the National Sanitation Foundation. Where make-up water for wash tank is provided from final rinse supply, chart recommendations are based upon this additional demand (not over 8 LPM) as required by NSF.

All sizings shown are that of the dishwasher manufacturers. Hatco Corporation is not responsible for incorrect sizing applications.

**SIZING CALCULATION**  
Rule of thumb for Hatco Electric  
Booster Water Heaters:

$$\frac{LPH}{38} = kW \text{ 22°C rise}$$





## Water Heater Data

### PLUMBING DATA

Dielectric couplings should be used in connecting dissimilar metals, such as galvanized to copper, to prevent electrolysis.

All Hatco Booster Water Heaters require 3/4" piping.

A check valve should not be installed in the supply line to the booster heater.

All shut-off valves must be gate or ball valves – not globe valves.

### BOOSTER HEATER SIZING FORMULA

$$\frac{\text{LPH} \times \text{°C Temp. Rise}}{840} = \text{kW}$$

NOTE: LPH is liters per hour.

### ELECTRICAL FORMULAS

$$\text{Watts} = \text{Amps} \times \text{Volts} \quad \text{1-phase}$$

$$\frac{\text{Watts} \times .86}{\text{Volts}} = \text{Amps} \quad \text{3-phase (open delta)}$$

$$\frac{\text{Watts}}{\text{Volts} \times 1.73} = \text{Amps} \quad \text{3-phase (balanced delta)}$$

### WATER TEMPERATURE RECOVERY TABLE IN LPH °C RISE

kW	16°	22°	28°	33°	39°	44°	50°	55°
4	204	151	121	102	87	76	68	61
5	254	189	151	125	110	95	83	76
6	303	227	182	151	129	114	102	91
7	356	265	212	178	151	133	117	106
9	454	341	273	227	197	170	151	136
9.9	500	375	299	250	216	189	167	151
10.5	530	398	318	265	227	201	178	159
11.4	581	433	350	289	247	217	194	175
12	610	454	363	303	261	227	204	182
13.5	685	511	409	341	292	257	227	204
15	761	572	454	379	326	284	254	227
17.25	874	655	526	435	375	329	292	261
18	912	685	549	454	390	341	303	273
24	1215	912	731	610	522	454	405	363
27	1367	1026	821	685	587	511	454	409
30	1518	1139	912	761	651	572	507	454
36	1825	1367	1094	912	780	685	610	549
39	1976	1480	1185	988	848	742	659	594
40.5	2052	1541	1230	1026	878	768	685	617
45	2279	1711	1367	1139	977	856	761	685
54	2737	2052	1643	1367	1174	1026	912	821
57	2888	2169	1734	1442	1234	1083	963	867

### SEE BOOSTER HEATER SIZING CHART, PAGES 174-176.

NOTE: When primary temperatures are less than 29°C consult factory for suitable booster heater.

## Sizing Chart For Low-Temp Dishmachines

BOOSTERS RATED AT 16°C RISE

Dishwasher Model Number	Electric Compact Booster	Electric Imperial Booster	Dishwasher Model Number	Electric Compact Booster	Electric Imperial Booster
<b>AMERICAN DISH SERVICE</b>			<b>CHAMPION</b>		
AH, AH-3D, AH-3D-S, AHC, AHC-3D, AHC-3D-S, ET-A, ET-AF, ET-AH, ET-A-M, ET-AH-M, ET-A-3, ET-AH-3, L-90-3D, L-90-3D-K, L-90-3D-K-S, L-90-3D-S, L-90-3DC, L-90-3DC-K, L-90-3DC-K-S, L-90-3DC-S, L-90-3DW, L-90-3DW-K, L-90-3DW-K-S, L-90-3DW-S, L-90-3DWC, L-90-3DWC-K, L-90-3DWC-K-S, L-90-3DWC-S, WH, WHC	C-4	S-6	ULD, ULF	C-6	S-6
A-3D, A-3D-S, A, AC, AC-3D, AC-3D-S, AH-B, ET-AF-3, ET-AF-M, HT-25, L-60-3D, L-60-3D-K, L-60-3D-K-S, L-60-3D-S, L-60-3DC, L-60-3DC-K, L-60-3DC-K-S, L-60-3DC-S, L-60-3DW, L-60-3DW-K, L-60-3DW-K-S, L-60-3DW-S, L-60-3DWC, L-60-3DWC-K, L-60-3DWC-K-S, L-60-3DWC-S, L-72-3D, L-72-3D-K, L-72-3D-K-S, L-72-3D-S, L-72-3DC, L-72-3DC-K, L-72-3DC-K-S, L-72-3DC-S, L-72-3DW, L-72-3DW-K, L-72-3DW-K-S, L-72-3DW-S, L-72-3DWC, L-72-3DWC-K, L-72-3DWC-K-S, L-72-3DWC-S, W, WC	C-5	S-6	DLF	C-13	S-13
A-B, AD-25, SS-25, 5-AH, 5-AHS	C-6	S-6	KL44, KL66	C-36	S-36
AF, AF-3D, AF-3D-S, AF-B, AFC, AFC-3D, AFC-3D-S, AFW, AFWC, 5, 5-S	C-7	S-7	<b>CMA DISHMACHINES</b>		
ADC-44, ADC-66, 5-AG, 5-AGS, 5-CD-LF, 5-CD-RF	C-9	S-9	A-1, AH-1, C-1, VAC-1, A-3, AH-3, C-3, L-1C, VAC-3, VAC-4, VAC-5, L-1X	C-4	S-6
<b>BLAKESLEE</b>			A-2, AH-1, AH-2, AH-3, B-3, C-1, C-2, C-3, EVA-1, EVA-2, EVA-3, EVA-4, EVA-5, VAC-2	C-6	S-6
U21-C	C-4	S-6	B-1	C-7	S-7
D-8-LT	C-6	S-6	B-2	C-9	S-9
DD-8-LT, R-CC64-LT, R-EE-LT	C-12	S-12	CMA-44L with tank heater, CMA-66L	C-24	S-24
Series XF-EE-LT, XF-PEE-LT, XF-PLL-LT, XF-PLL-LT, XF-MM-LT, XF-PMM-LT, XF-EEE-LT, XF-LLL-LT, XF-MMM-LT	C-13	S-13	CVA-1, CVA-2, CVA-3, CVA-4	C-6	S-6
Series R-L-LT, R-PL-LT, R-M-LT, R-PM-LT, F-L-LT, F-PL-LT, F-M-LT, F-PM-LT (single tank)	C-36	S-36	CVA-5	C-7	S-7
Series "R" & "F" - CC-LT, -EE-LT, -LL-LT, -MM-LT, -LLL-LT, -MMM-LT, -PCC-LT, -PEE-LT, -PLL-LT, -PMM-LT (multi-tank)	C-24	S-24	<b>HOBART</b>		
Series XF-L-LT, XF-PL-LT, XF-M-LT, XF-PM-LT (single tank)	C-54	S-54	LX-18C, LX-30C, LX-40C, WM-5C, SR24C	C-4	S-6
Series XF-PEE-LT, XF-PLL-LT, XF-PMM-LT, XF-EEE-LT, XF-LLL-LT, XF-MMM-LT (multi-tank)	C-36	S-36	LT-1	C-6	S-6
FA (Flight-A-Round) and RA (Rack-A-Round) use comparable "F" listing.			AM-14, AM-14C	C-7	S-7
			C44A, CRS66A, CPW80A	C-27	S-27
			FT-800	C-30	S-30
			<b>JACKSON</b>		
			Conservar 24LT, 200LT, ES1000 (Ecolab/Jackson)	C-4	S-6
			Conservar 1, Conservar XL, ES2000 (Ecolab/Jackson)	C-9	S-9
			Conservar 2, Conservar XL2, ES4000 (Ecolab/Jackson)	C-15	S-15
			AJ-44, AJ-66, AJ-80	C-18	S-18
			<b>KNIGHT EQUIPMENT LTD.</b>		
			KLE-112-HL	C-5	S-6
			KLE-117i, KLE-117c, KLE-175GT, KLE-175GTM,	C-9	S-9
			KLE-235d	C-13	S-13
			KLE-175GT Corner, KLE-175GTM Corner	C-12	S-12

## Low-Temp Sizing Data

Chemical low-temp dishwashers are most effective when supplied with a 60°C hot water supply. Sometimes this water temperature is not available due to undersized primary water heaters or local safety codes. Hatco can supply a pre-heater for chemical low-temp dishwashers to provide an adequate supply of 60°C hot water for proper operation.

NOTE: When ordering a heater for use with a chemical low-temp dishwasher, thermostat adjustments for low-temp applications are the responsibility of the installer.

### To properly size a Hatco heater for low-temp use:

- Determine the required temperature rise by subtracting the available hot water supply temperature from 60°C. This should be a minimum of 11°C.
- Determine the water usage by consulting the dishwasher data plate, literature or NSF listing. This should be shown as liters per hour (LPH).
- Use the Hatco formula for sizing or the sizing chart on this page to determine the required kW and select the appropriate Hatco model.



## Food Pans And Trivets



ALUM PAN

18" SHEET PAN



PIZZA PANS  
14" PIZZA PAN  
16" PIZZA PAN  
18" PIZZA PAN



ST PANS  
ST PAN 1/3  
ST PAN 1/2  
ST PAN 2  
ST PAN 4

### FOOD PANS

Model	Description	Dimensions	List Price
ALUM PAN	Half-Size Sheet Pan	457 W x 330 D mm	\$28
18" SHEET PAN	Full Size Sheet Pan	457 W x 660 D mm	39
14" PIZZA PAN	Perforated Pizza Pan	356 mm Diameter	30
16" PIZZA PAN	Perforated Pizza Pan	406 mm Diameter	33
18" PIZZA PAN	Perforated Pizza Pan	457 mm Diameter	35
ST PAN 1/3	Third-Size Stainless Steel Pan	324 W x 175 D x 64 H mm	50
ST PAN 1/2	Half-Size Stainless Steel Pan	324 W x 264 D x 64 H mm	56
ST PAN 2	Full-Size Stainless Steel Pan	324 W x 527 D x 64 H mm	68
ST PAN 4	Full-Size Stainless Steel Pan	324 W x 527 D x 102 H mm	86



HDW TRIVET



HDW-SPLASH



HDW 6" PAN



#### Additional Humidity

A. Stainless Steel Food Pan

B. Splash Baffle  
HDW-SPLASH Accessory

C. Water/Spillage Pan (add 6 mm of water)  
HDW-SPILL Accessory

### FOOD PANS AND TRIVETS

Model	Description	Dimensions	List Price
HDW-TRIVET	Custom Trivet raises food product	13 mm off bottom of pan	\$ 50
HDW-SPLASH	Splash Baffle (One per drawer)		46
HDW-SPILL	Water/Spillage Pan (one per drawer)		231
HDW 6" PAN	Full-Size Stainless Steel Food Pan	324 W x 527 D x 152 H mm	94



TF-10SAUTE

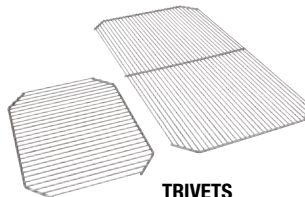

TRIVETS  
TRIVET (1/2)SS  
TRIVET SS

### FOOD PANS AND TRIVETS

Model	Description	Dimensions	List Price
TF-10SAUTE	Aluminum Saute Pan with Tapered Sides	254 mm	\$119
<b>Wire Trivets Stainless –</b>			
TRIVET (1/2)SS	Half-Size	259 W x 194 D mm	\$ 94
TRIVET SS	Full Size	257 W x 457 D mm	128

## GENERAL INFORMATION

**Price Policy:** Prices are in United States dollars and are subject to change without notice. Prices and discounts apply to accessories at time of initial equipment order only, not when ordered at a later date.

**Standard Payment Terms:** Cash in advance of shipment or as negotiated.

Hatco Banking Coordinates:

JP Morgan Chase Bank  
131 S. Dearborn, 6th Floor  
Chicago, IL 60603 U.S.A.  
S.W.I.F.T. No: CHASUS33, TELEX: 6733943  
Favour: Hatco Account Number: 632687315

**Standard Shipment Terms:** EX-WORKS Sturgeon Bay, WI, 54235 U.S.A.

**Freight Classification:** Water Heating equipment Class 85,  
Refrigerated Drop-In Wells and Glo-Ray® Heated Display Cases class 125  
all other equipment Class 100.

ALL HATCO PRODUCTS SHIPPED WITH INSTALLATION AND OPERATING INSTRUCTIONS. CONSULT LOCAL CODES BEFORE INSTALLING EQUIPMENT.

**E-mail inquiries and requests to:** [support@hatcocorp.com](mailto:support@hatcocorp.com)

**E-mail orders to:** [intlsales@hatcocorp.com](mailto:intlsales@hatcocorp.com)

**Telephone:** (414) 671-6350

**[www.hatcocorp.com](http://www.hatcocorp.com)**

Hatco products are manufactured for commercial use only. See product specification sheet for the appropriate approvals.

### Water Quality Requirements

Water supply in excess of .75 grains of hardness per liter (GPL) must be treated and softened before being used. Water containing over .75 GPL will decrease the efficiency and reduce the operating life of the unit.

**NOTE:** Product failure caused by liming or sediment buildup is not covered under warranty.

**NOTE:** See pages 173 for Blended Phosphate Water Treatment System.



## Limited Warranty

For the full information pertaining to the Hatco warranty protection for your equipment, go to our website at:

[www.hatcocorp.com](http://www.hatcocorp.com)

Step 1: make sure you are on your region

Step 2: in the **SUPPORT** drop-down at the top of the page, select **WARRANTY**

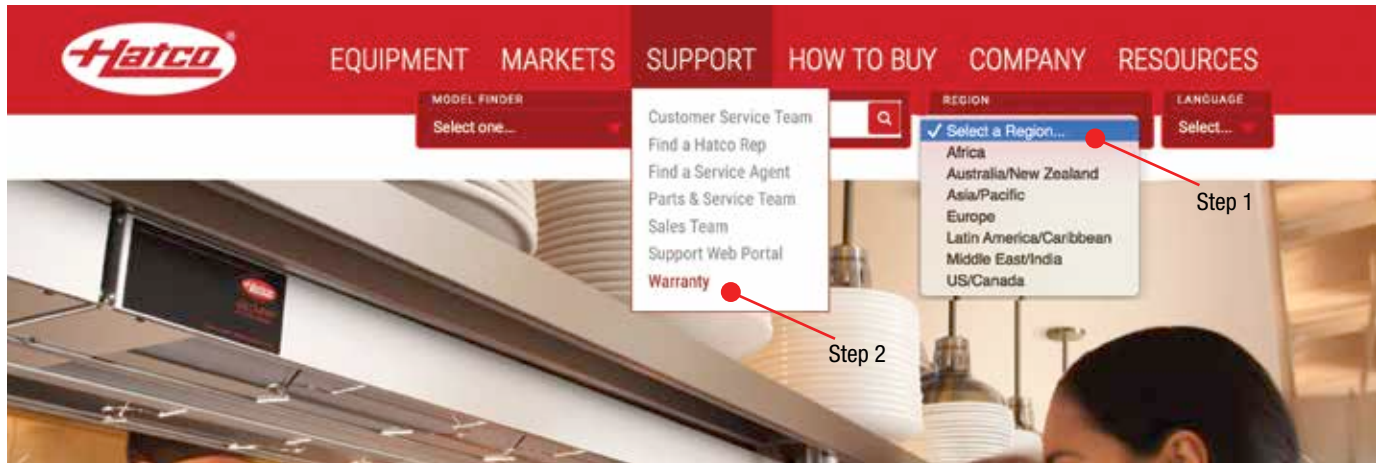

## Ordering Procedures

### CUSTOMER NOTE –

To ensure prompt and accurate processing of your order, please provide the following information:

### ALL PRODUCTS –

1. Model number, voltage, 50 and 60 Hertz and phase, specify if CE Mark is required.
2. Specify options and accessories as required. Options are not retrofittable.
3. Consult factory when ordering equipment for special applications.
4. E-mail orders are acceptable and do not require confirmation.

**ALL WATT RATINGS ARE NOMINAL. ACTUAL WATTAGE MAY VARY.  
CONSULT FACTORY FOR MORE INFORMATION.**

## Returns

No product will be accepted on a return shipment without a Material Return Authorization from Hatco Export Sales Department. Products returned at customer's convenience are subject to inspection and a restocking charge of 25% of EX-WORKS, freight and related expenses for shipper's account; contact Hatco Export Department. Decorative Heat Lamps (DL Series) are non-returnable.

## DAMAGED FREIGHT POLICY

All freight should be inspected during the receiving process for possible damage. Should there be a question about the condition of the equipment, it is better to refuse the shipment. If damage is found after delivery, it is the consignee's (receiver) responsibility to notify the carrier within **5 days** of delivery.

All Hatco Shipments specify an Incoterm 2010 in which the shipment was made. Incoterms determine who bears the risk of cargo damage or loss at any given point of shipment and therefore who pays in the event of loss or damage. If it is found that any part of the shipment has sustained damage during transportation, Hatco Corporation must be contacted as well as immediately notifying the last carrier.

For assistance, contact Hatco via e-mail at: [intlshipping@hatcocorp.com](mailto:intlshipping@hatcocorp.com) and provide information listed below

1. Hatco Shipment Number
2. Delivery date and date damage was discovered
3. Contact name, phone number and email address
4. Type of unit damaged including model and serial number
5. Extent of damage
6. Pictures of damage as well as packaging





**HAVE A QUESTION?  
CHAT WITH HATCO**  
SEE ICON ON RIGHT SIDE OF WEBSITE

Hatco has a wealth of resources to help you choose and order the correct equipment with ease. Log on to the Hatco website: [www.hatcocorp.com](http://www.hatcocorp.com) and look under the “Resources” panel on the right hand side of the page.



- RESOURCES**
- Build a Lamp
  - CAD/Revit Drawings
  - Choose Remote Box
  - Document Library
  - Equipment Shipping Info
  - FAQs
  - Find a Hatco Rep
  - Image Library
  - Order Literature
  - Program Your Toaster
  - Training Schools
  - Video Library

**BUILD A LAMP**



**CHOOSE REMOTE BOX**

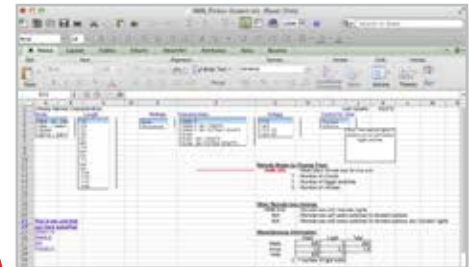

**DOCUMENT LIBRARY**

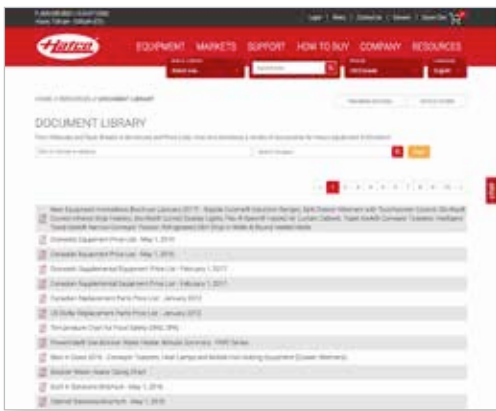

**EQUIPMENT SHIPPING INFO**



**VIDEO LIBRARY**

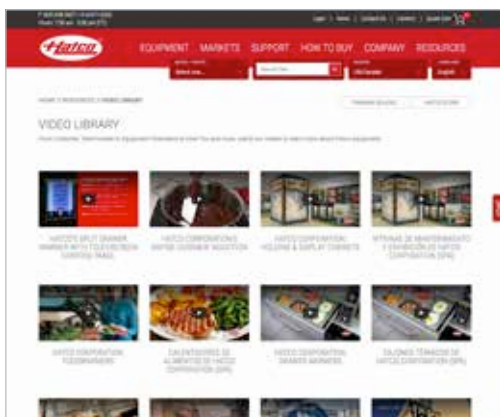

**IMAGE LIBRARY**









## PRODUCT INDEX

<b>WELLS</b>	2-35	<b>DRAWER WARMERS</b>	115-119
<b>DECORATIVE LAMPS &amp; DISPLAY LIGHTS</b>	36-45	<b>MERCHANDISERS</b>	120-134
<b>STRIP HEATERS</b>	46-74	<b>HOLDING &amp; DISPLAY CABINETS</b>	135-151
<b>FRY STATIONS</b>	75-80	<b>TOASTERS</b>	152-158
<b>CARVING STATIONS</b>	81-83	<b>INDUCTION</b>	159-161
<b>PORTABLES</b>	84-96	<b>LIGHT COOKING EQUIPMENT</b>	162-165
<b>BUILT-INS</b>	97-114	<b>WATER HEATING/SPECIALTY EQUIPMENT</b>	166-177

3CS .....	167	GRA-xxD, GRAH-xxD .....	55, 57	HWBRN, HWBRNQ. .... <b>NEW</b> .....	30-32, 34-35
C .....	169-170	GRAL, GRAHL .....	53-54	HWBRT, HWBRTQ. .... <b>NEW</b> .....	30-32, 34-35
CDW .....	116	GRAL-xxD, GRAHL-xxD .....	56-57	HWBRN-xQT .....	33-35
Chef LED. .... <b>NEW</b> .....	45	GRAIH, GRAIHL .....	60, 62	HWBRT-xQT .....	33-35
CSBF, CSBFR, CSBFX .....	101-102	GRAIH-xxD, GRAIHL-xxD .....	61-62	HXMH, HXMH-xxD .....	127-128
CSSB, CSSBR CSSBX .....	98	GR-B .....	76-77	HXMS, HXMS-xxD .....	127-128
CSSBF, CSSBFR, CSSBFX .....	99-100	GRBW .....	95-96	IHDCH. .... <b>NEW</b> .....	141-142
CSU, CSUR, CSUX .....	103-104	GRCD, GRCDH. ....	131-132	IRNG-PC1, -PB1 .....	159-161
CWB, CWB-S .....	6-8, 12	GRCMW .....	130	ITQ. .... <b>NEW</b> .....	153
CWBR, CWBR-S, CWBX, CWBX-S .....	9-12	GRCSC, GRCSC LH .....	83	IWB, IWB-S .....	4-5, 12
DCS .....	82	GRFF, GRFFL, GRFFB, GRFFBL .....	76-77	LW .....	85
DL, DLH .....	37-42	GRFHS .....	79-80	MDW .....	144
FDWD-1-MN .....	145	GRFS .....	79-80	MPWS. ....	78
FDWD .....	136, 139-140	GRHD, GRHDH. ....	133-134	PFST. ....	146
FR .....	168	GRHW .....	94	RMB .....	74
FS2HAC .....	151	GRN, GRNH .....	58-59	S .....	171-172
FSD, FSDT .....	137-140	GRPWS. ....	121	SAL .....	164
FSHAC .....	151	GRS .....	87-89	SNACK. .... <b>NEW</b> .....	163
FSHC-5W .....	147	GRSB .....	113	TF. ....	165
FSHC-6W .....	149	GRSBF .....	114	TFW .....	165
FSHC-7W .....	147	GRSDH, GRSDH-xxD .....	123-124	TK. ....	157-158
FSHC-7. ....	150	GRSDS, GRSDS-xxD .....	123-124	TQ .....	155-156, 158
FSHC-12W .....	148	GRSDS/H .....	122	TQ3 .....	154
FSHC-17W .....	148	GRSR .....	86	UGA, UGAH .....	69, 71
FST-1-MN .....	145	GRSS .....	92	UGA-xxD, UGAH-xxD .....	70-71
FTB, FTB-S .....	13-14	GRSSB .....	110	UGAL, UGAHL .....	69, 71
FTBR, FTBX .....	15-16	GRSSR .....	90-91	UGAL-xxD, UGAHL-xxD .....	70-71
GR, GRH .....	53-54	HBG .....	93	UGFF, UGFFL, UGFFB, UGFFBL .....	76-77
GR2A, GR2AH .....	63, 65	HGBG, HGBGH. ....	111, 112	WFST .....	143
GR2A-xxD, GR2AH-xxD .....	66, 68	HCSBF, HCSBFR, HCSBFX .....	108-109		
GR2AL, GR2AHL .....	64-65	HCSSB, HCSSBR, HCSSBX .....	105		
GR2AL-xxD, GR2AHL-xxD .....	67-68	HCSSBF, HCSSBFR, HCSSBFX .....	106-107		
GR2BW .....	95-96	HDW .....	117-119		
GR2S .....	89	HL .....	43		
GR2SDH, GR2SDH-xxD .....	125-126	HL5 .....	<b>NEW</b> .....		
GR2SDS, GR2SDS-xxD .....	125-126	HW .....	3		
GR3SDS-39DCT, GR3SDS-39TCT .....	129	HWB, HWBQ. .... <b>NEW</b> .....	24-27, 34-35		
GR5A GR5AH. .... <b>NEW</b> .....	49	HWB-, HWBI-xQT .....	28-29, 34-35		
GR5AL, GR5AHL. .... <b>NEW</b> .....	50-51	HWBI, HWBI43. .... <b>NEW</b> .....	17-19, 34-35		
GRA, GRAH .....	52, 54	HWBI-S. ....	20-21, 34-35		



## Paint Chip and Stone Sample Colors

### DESIGNER COLORS



Warm Red



Black



Gray  
Granite



White  
Granite



Navy  
Blue



Hunter  
Green



Antique  
Copper

### GLOSS FINISHES



Smooth  
White



Gleaming  
Gold



Glossy  
Gray



Bold  
Black



Radiant  
Red



Brilliant  
Blue



Clear Brushed  
Metal Finish

### PLATED FINISHES



Bright  
Brass



Bright  
Nickel



Bright  
Copper



Antique  
Nickel



Antique  
Brass



Antique  
Bronze

### SIMULATED STONE COLORS\*



Gray  
Granite



Bermuda  
Sand



Night Sky

*Colors are a representation and may not exactly match our colors.  
Consult factory for possible color matching options on these colors.  
Non-standard colors are non-returnable.*

To order a Hatco Paint Chip & Stone Sample Colors Sheet, visit [www.hatcocorp.com](http://www.hatcocorp.com) / *Order Literature* / *Sales Literature* / *Sell Sheets*.

\* Simulated Stone is Swanstone®

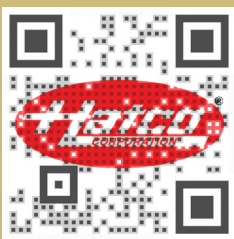

People who serve, products that solve.®

