

*Barware*  
COLLECTION



**ONEIDA<sup>®</sup>**  
Designing the dining experience.™

A Rich Heritage and a

# Sparkling Future...

Oneida exists to lead the tabletop industry in innovative, authentic design, working with operators to create unique and unforgettable dining experiences for their guests. Fueled by an unmatched legacy and a forward-thinking mentality, Oneida creates innovative yet timeless solutions designed to match any owner or operator's desired look and feel. Marked by quality, service and dedicated commitment to customers, Oneida offers a dynamic assortment of world-class glassware for any bar service.

## Item Descriptions

Throughout the barware catalog you will see information below each item. The guide below helps specify what each description means.



item number — 90254 — symbols  
capacity — 14 oz. Beverage — item number  
height — H 5 3/8" | D 3 3/8" — diameter  
case pack info. — 2 doz. | 22.6 lbs. | 1.03 cu. ft.

- Fully Tempered
- Rim Tempered
- Proprietary Product
- ★ 1 Dozen Inner Cartons
- ▼ Stackable Product
- Can be used with Serving Paddle
- Can be used with Flight Carrier

# Table of Contents

BARWARE & TUMBLERS	1-26
STEMWARE	27-30
MARTINI'S	31-32
SPECIALTY	32-34
METAL DRINKWARE	35-36
PERFECT PORTIONS	37-38
SHOT GLASSES & SHOOTERS	39
WATER BOTTLES, PITCHER AND CARAFES	40
DESSERT & COFFEE MUGS	41-42
SALT & PEPPER, VOTIVES & ASHTRAYS	43
CARE & HANDLING	44
TOOLS OF THE TRADE	45
GLASSWARE REQUIREMENTS	46
OUR PROMISE TO YOU & SUREGUARD™ GUARANTEE	47

## Brands Featured

**ONEIDA®**

 **ANCHOR  
HOCKING®**







# Alpha™



**10406 ■**  
10 oz. Rocks  
H 3 ¾" | D 3 ¼"  
2 doz. | 16 lbs. | 1.03 cu. ft.



**10408 ■**  
14 oz. Tea  
H 5 ¼" | D 3 ¾"  
2 doz. | 20 lbs. | 1.30 cu. ft.

## Alpha™

Delivering a classic but contemporary design, Alpha combines the simplicity of a slightly tapered shape together with an upscale weighted base. The handsome style blends nicely with any dinnerware pattern and is wonderful for cocktails, iced teas and lemonade. Alpha is rim-tempered for added durability.



# Augusta™



**10402** ■  
11 oz. D.O.F.  
H 3 ¾" | D 3 ⅝"  
2 doz. | 17 lbs. | .1 cu. ft.



**10404** ■  
14 oz. Cooler  
H 6" | D 3 ¼"  
2 doz. | 24 lbs. | .1 cu. ft.



**10405** ■  
16 oz. Cooler  
H 6 ¼" | D 3 ¼"  
2 doz. | 24 lbs. | 1.17 cu. ft.

## Augusta™

Augusta Barware from Anchor Hocking delivers an excellent combination of functionality and affordability. Designed in the spirit of Southern Hospitality, Augusta Barware is the perfect choice for any dining establishment seeking a warm welcoming atmosphere. The molded side walls provide the look and feel of cut glass. This durable barware collection is available in five capacities and is rim-tempered for added durability.



Barware Collection







# Clarisse™ Stackable



**90252** ■ ● ▼  
10 oz. Rocks  
H 3 5/8" | D 3 1/2"  
2 doz. | 22 lbs. | 0.82 cu. ft.



**90262** ■ ● ▼  
8 oz. Rocks  
H 3 1/2" | D 3 1/4"  
2 doz. | 16 lbs. | TBD cu. ft.



**90253** ■ ● ▼  
12 oz. DOF  
H 3 7/8" | D 3 5/8"  
2 doz. | 26 lbs. | .95 cu. ft.



**90254** ■ ● ▼  
14 oz. Beverage  
H 5 3/8" | D 3 3/8"  
2 doz. | 22.6 lbs. | 1.03 cu. ft.



**90255** ■ ● ▼  
16 oz. Cooler  
H 5 3/4" | D 3 5/8"  
2 doz. | 25 lbs. | 1.21 cu. ft.



**90263** ■ ● ▼  
20 oz. Cooler  
H 6 1/2" | D 4"  
2 doz. | 42 lbs. | 1.66 cu. ft.

Pyramiding is  
the preferred  
method to  
stack & store.

## Seamless Design

The stacking seam disappears when beverage is poured into the glass!





*Clarisse™*



**77787** ■ ●  
7 oz. Rocks  
H 3 3/8" | D 3 1/4"  
3 doz. | 26 lbs. | 0.98 cu. ft.



**77770** ■ ●  
10 oz. Rocks  
H 3 3/4" | D 3 1/2"  
3 doz. | 33 lbs. | 1.23 cu. ft.



**77790R** ■ ●  
12 oz. Rocks  
H 4" | D 3 5/8"  
3 doz. | 39 lbs. | 1.42 cu.ft.



**77792R** ■ ●  
12 oz. Beverage  
H 4 7/8" | D 3 1/4"  
3 doz. | 38 lbs. | 1.38 cu. ft.



**77794** ■ ●  
14 oz. Beverage  
H 5 1/8" | D 3 3/8"  
3 doz. | 34 lbs. | 1.55 cu.ft



**77796** ■ ●  
16 oz. Cooler  
H 6 1/8" | D 3 3/8"  
3 doz. | 38 lbs. | 1.82 cu. ft.



**1170U** ●  
10 oz. Beer  
H 5 7/8" | D 4 7/8"  
1 doz. | 25 lbs. | .78 cu. ft.



**1172U** ●  
12 oz. Beer  
H 5 7/8" | D 4 7/8"  
1 doz. | 21 lbs. | .78 cu. ft.





# New Orleans



**90004**  
4 ½ oz. Rocks  
H 3 ⅛" | D 2 ⅞"  
3 doz. | 23 lbs. | 0.73 cu. ft.



**90005**  
5 oz. Rocks  
H 3 ⅛" | D 2 ⅞"  
3 doz. | 20 lbs. | 0.77 cu. ft.



**90006** ■  
7 oz. Rocks  
H 3 ⅜" | D 2 ⅞"  
3 doz. | 27 lbs | 1.01 cu. ft.



**90007** ■  
8 oz. Rocks  
H 3 ⅜" | D 3 ⅞"  
3 doz. | 27 lbs | 1.06 cu. ft.



**90008** ■  
9 oz. Rocks  
H 3 ⅜" | D 3 ⅜"  
3 doz. | 22 lbs | 1.07 cu. ft.



**799U**  
9 oz. Rocks  
H 3 ⅞" | D 3 ½"  
3 doz. | 30 lbs. | 1.26 cu. ft.



**90009**  
10 oz. Rocks  
H 3 ⅞" | D 3 ½"  
3 doz. | 30 lbs. | 1.27 cu. ft.



**90010** ■  
12 oz. Double Rocks  
H 4 ¼" | D 3 ⅞"  
3 doz. | 36 lbs | 1.61 cu. ft.



**7729U** ■  
9 oz. Hi-Ball  
H 4 ¾" | D 3 ⅞"  
3 doz. | 35 lbs. | 1.28 cu. ft.



**7730U** ■  
10 oz. Beverage  
H 4 ¾" | D 3 ⅞"  
3 doz. | 30 lbs. | 1.28 cu. ft.



**7732U** ■  
12 oz. Beverage  
H 4 ⅞" | D 3 ⅞"  
3 doz. | 36 lbs. | 1.51 cu. ft.



**7745U** ■  
14 ½ oz. Iced Tea  
H 5 ⅞" | D 3 ⅞"  
3 doz. | 38 lbs. | 1.79 cu. ft.



**7733U** ■  
12 oz. Cooler New Orleans  
H 5 ⅞" | D 3 ⅞"  
3 doz. | 34 lbs. | 1.54 cu. ft.



**7746** ■  
16 oz. Cooler New Orleans  
H 6 ⅜" | D 3 ⅞"  
3 doz. | 40 lbs. | 1.98 cu. ft.



**7772** ■  
22 oz. Iced Tea New Orleans  
H 7" | D 3 ¾"  
2 doz. | 37 lbs. | 1.72 cu. ft.

■ Rim  
Tempered





# Omega™



**90236** ■  
16 oz. Cooler  
H 6 3/8" | D 3 3/8"  
1 doz. | 20.5 lbs. | 0.24 cu. ft.



**90235** ■  
13 1/2 oz. Beverage  
H 5 5/8" | D 3 3/8"  
1 doz. | 18.4 lbs. | 0.19 cu. ft.



**90234** ■  
12 oz. Rocks  
H 4 1/2" | D 3 1/2"  
1 doz. | 17.6 lbs. | 0.17 cu. ft.



**90270** ■  
10 oz. Rocks  
H 4 1/8" | D 3 1/2"  
1 doz. | 9 lbs. | 0.92 cu. ft.



**90237**  
6 oz. Carafe  
H 5 3/4" | D 2 1/4"  
2 doz. | 11.6 lbs. | 0.70 cu. ft.

# Omega™

The Omega Collection is ideal for any operations requiring high fashion trend-forward barware. Thick bases and flared tops offer and upscale appearance and service.

The 6 oz. Carafe is perfect for portion control and wine table service. Rim-tempered for added durability, Omega is ideal for fast paced establishments.

■ Rim  
Tempered



Barware Collection



# Reality™



**90072** ■  
8 oz. Rocks  
H 3 1/4" | D 3 3/8"  
2 doz. | 14 lbs. | 0.91 cu. ft.



**90044** ■  
10 oz. Rocks  
H 3 3/4" | D 3 3/8"  
2 doz. | 14 lbs. | 0.91 cu. ft.



**90045** ■  
12 oz. Rocks  
H 3 7/8" | D 3 1/2"  
2 doz. | 14 lbs. | 0.91 cu. ft.



**90046** ■  
14 oz. Tumbler  
H 5 1/8" | D 3 1/4"  
2 doz. | 17 lbs. | 1.06 cu. ft.



**90047** ■  
16 oz. Cooler  
H 5 5/8" | D 3 1/4"  
2 doz. | 23 lbs. | 1.06 cu. ft.



**90048** ■  
20 oz. Cooler  
H 6" | D 3 1/2"  
2 doz. | 25 lbs. | 1.27 Cu. ft.

# Reality™

The Reality pattern is the perfect blend of fashion, sophistication, elegance and durability. The nicely proportioned stylish design brings an upscale look to the handsome piece, and helps eliminate the rim-to-rim contact. The substantial base delivers a cut crystal look typical of high-end glassware and adds stability to the table. Rim-tempered for added durability, the controlled bead gives an elegant upscale look to the finely crafted piece. The Reality tumbler makes a great addition to any table setting.





*Solace™*



**90051A** ■●  
5 oz. Juice  
H 3 5/8" | D 2 1/2"  
2 doz. | 5 lbs. | 0.56 cu. ft.



**90052A** ■●  
7 oz. Juice  
H 3 7/8" | D 3 1/2"  
2 doz. | 12 lbs. | 0.75 cu. ft.



**90053A** ■●  
10 oz. Water  
H 4 5/16" | D 3 1/4"  
2 doz. | 15 lbs. | 1.02 cu. ft.



**90054A** ■●  
15 3/4 oz. Cooler  
H 5 5/8" | D 3 1/4"  
2 doz. | 21 lbs. | 1.18 cu. ft.

■ Rim Tempered    ● Proprietary Product

*Solace™*

Designed especially for the growing healthcare food market, Solace is a simple, practical and stylish solution to dressing up a table. The heavy base helps reduce tipping and the rim is designed to accept standard plastic lids to prevent spilling while transporting drinks from the kitchen to the table.



Barware Collector





# Ribware



**7637U** ■

12 oz. Beverage

H 5 3/8" | D 3 1/8"

3 doz. | 26 lbs. | 1.46 cu. ft.



## Vino Redux



**11868**  
16 oz. Cooler  
H 5 5/8" | D 3"  
2 doz. | 15.6 lbs. | .89 cu. ft.



**11869**  
10 oz. Rocks  
H 3 5/8" | D 3"  
3 doz. | 15.6 lbs. | .89 cu. ft.



**11872**  
20 oz. Pitcher  
H 7 3/4" | D 3 1/2"  
1/2 doz. | 6 lbs. | .89 cu. ft.



**11870**  
16 oz. Cooler  
H 3 5/8" | D 3"  
3 doz. | 15.6 lbs. | .89 cu. ft.



**11871**  
10 oz. Rocks  
H 3 5/8" | D 3"  
3 doz. | 15.6 lbs. | .89 cu. ft.



**11934**  
20 oz. Pitcher  
H 7 3/4" | D 3 1/2"  
1/2 doz. | 6 lbs. | .89 cu. ft.

## Straight Sided Shells™



**3532U** ■  
12 oz. Zombie  
H 6 1/8" | D 2 1/4"  
6 doz. | 35 lbs. | 2.01 cu. ft.



**3532/6721U**  
12 oz. Zombie Frosted  
H 6 1/8" | D 2 1/4"  
6 doz. | 35 lbs. | 2.01 cu. ft.



**7511U** ■  
6 oz. Seltzer  
H 3 1/2" | D 2 3/8"  
6 doz. | 20 lbs. | 1.08 cu. ft.



**7514U** ■  
10 oz. Collins  
H 4 3/4" | D 2 3/4"  
6 doz. | 30 lbs. | 1.81 cu. ft.



# Heavy Base



**3108U**  
8 oz. Hi-Ball  
H 4 <sup>7</sup>/<sub>8</sub>" | D 2 <sup>1</sup>/<sub>2</sub>"  
6 doz. | 38 lbs. | 1.64 cu. ft.



**3113U**  
13 oz. Double Rocks  
H 4" | D 3 <sup>5</sup>/<sub>8</sub>"  
3 doz. | 29 lbs. | 1.43 cu. ft.



**3165U**  
5 oz. Side Water  
H 3 <sup>1</sup>/<sub>2</sub>" | D 2 <sup>3</sup>/<sub>8</sub>"  
6 doz. | 28 lbs. | 1.08 cu. ft.



**3169U**  
9 oz. Hi-Ball  
H 4 <sup>3</sup>/<sub>4</sub>" | D 2 <sup>5</sup>/<sub>8</sub>"  
6 doz. | 39 lbs. | 1.82 cu. ft.



**3170U**  
10 <sup>1</sup>/<sub>2</sub> oz. Hi-Ball  
H 5 <sup>1</sup>/<sub>2</sub>" | D 2 <sup>7</sup>/<sub>8</sub>"  
6 doz. | 47 lbs. | 2.37 cu. ft.



**3172U**  
12 <sup>1</sup>/<sub>2</sub> oz. Beverage  
H 5 <sup>1</sup>/<sub>2</sub>" | D 2 <sup>7</sup>/<sub>8</sub>"  
6 doz. | 47 lbs. | 2.37 cu. ft.



**3175U**  
15 oz. Iced Tea  
H 6 <sup>1</sup>/<sub>4</sub>" | D 3"  
3 doz. | 30 lbs. | 1.42 cu. ft.



**3178FU**  
9 oz. Rocks  
H 3 <sup>1</sup>/<sub>4</sub>" | D 3 <sup>1</sup>/<sub>8</sub>"  
3 doz. | 20 lbs. | 0.91 cu. ft.



**3181EU**  
10 <sup>1</sup>/<sub>2</sub> oz. Collins  
H 6" | D 2 <sup>1</sup>/<sub>2</sub>"  
3 doz. | 22 lbs. | 1.06 cu. ft.

# Room Tumblers



**639U**  
8 oz. Rocks  
H 3 <sup>3</sup>/<sub>4</sub>" | D 3 <sup>1</sup>/<sub>8</sub>"  
1 doz. | 10 lbs. | 0.36 cu. ft.



**2238U**  
8 oz. Room Tumbler  
H 3 <sup>5</sup>/<sub>8</sub>" | D 2 <sup>3</sup>/<sub>4</sub>"  
6 doz. | 38 lbs. | 1.51 cu. ft.



**5060U**  
10 <sup>3</sup>/<sub>4</sub> oz. Room Tumbler  
H 3 <sup>1</sup>/<sub>2</sub>" | D 3 <sup>1</sup>/<sub>4</sub>"  
3 doz. | 25 lbs. | .97 cu. ft.



**2047U**  
10 <sup>1</sup>/<sub>4</sub> oz. Old Fashioned  
H 3 <sup>3</sup>/<sub>8</sub>" | D 3 <sup>1</sup>/<sub>4</sub>"  
3 doz. | 27 lbs. | 1.05 cu. ft.



# Concord



**2283Q**  
3 oz. Juice/Votive/Jigger  
H 2 3/8" | D 2 1/8"  
3 doz. | 10 lbs. | 0.39 cu. ft.



**3141U**  
10 1/2 oz. Old Fashioned  
H 3 1/2" | D 3 1/4"  
3 doz. | 27 lbs. | 1.05 cu. ft.



**3143U**  
12 1/2 oz. Dbl. Old Fashioned  
H 4" | D 3 1/4"  
3 doz. | 29 lbs. | 1.19 cu. ft.

# Tartan®



**68349** ●  
10 1/2 oz. Rocks  
H 3 1/2" | D 3 3/8"  
1 doz. | 10 lbs. | 0.38 cu. ft.



**68347** ●  
16 oz. Iced Tea  
H 6" | D 3 1/8"  
1 doz. | 15 lbs. | 0.53 cu. ft.

# Breckenridge™



**80009** ■  
9 oz. Hi-Ball  
H 4 7/8" | D 2 3/4"  
3 doz. | 23 lbs. | 1.04 cu. ft.



**80012** ■  
12 1/2 oz. Beverage  
H 5 3/8" | D 3 1/8"  
3 doz. | 25 lbs. | 1.33 cu. ft.



**80011** ■  
10 1/2 oz. Goblet  
H 6" | D 3 1/4"  
3 doz. | 35 lbs. | 1.82 cu. ft.

# Stackables™



**73012** ■ ● ▼  
12 oz. Beverage  
H 4 7/8" | D 3 1/4"  
3 doz. | 23.4 lbs. | 1.4 cu. ft.



**73014** ■ ● ▼  
14 oz. Beverage  
H 5 1/8" | D 3 1/4"  
3 doz. | 28.5 lbs. | 1.7 cu. ft.



**73017** ■ ● ▼  
16 oz. Cooler  
H 6" | D 3 1/8"  
3 doz. | 35 lbs. | 1.92 cu. ft.



**73020** ■ ● ▼  
20 oz. Cooler  
H 6 1/2" | D 3 3/4"  
2 doz. | 32 lbs. | 1.56 cu. ft.

■ Rim Tempered    ● Proprietary Product    ▼ Stackable Product

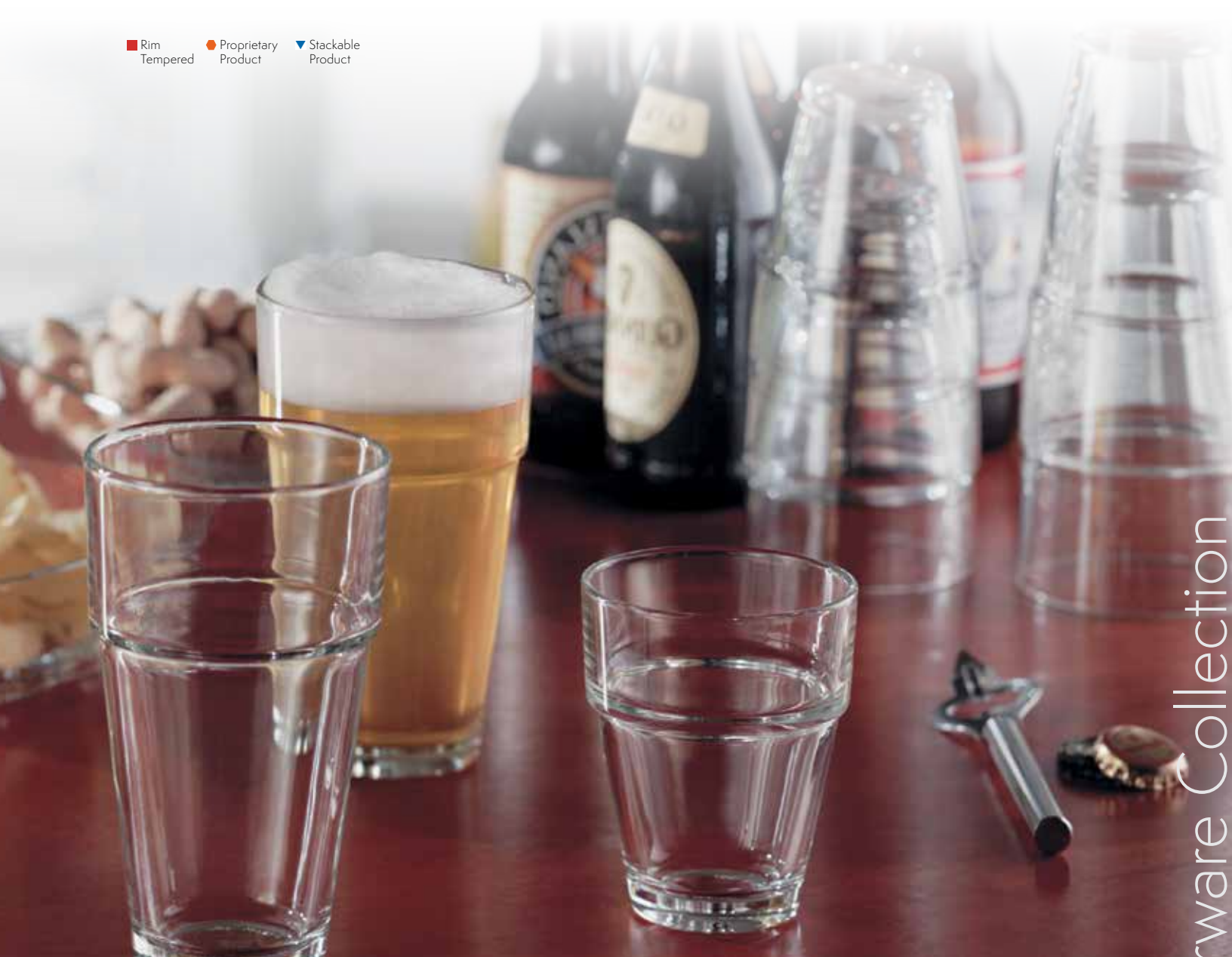

# Beer Pilsners



**7410U** ■  
10 oz. Bavarian Pilsner  
H 5 3/4" | D 2 7/8"  
3 doz. | 23 lbs. | 1.20 cu. ft.



**7412U** ■  
12 oz. Bavarian Pilsner  
H 6" | D 3 1/4"  
3 doz. | 27 lbs. | 1.59 cu. ft.



**7415U** ■  
15 oz. Bavarian Pilsner  
H 6 5/8" | D 3 1/4"  
3 doz. | 30 lbs. | 1.91 cu. ft.



**90054A** ■  
15 3/4 oz. Solace Cooler  
H 5 5/8" | D 3 1/4"  
2 doz. | 21 lbs. | 1.18 cu. ft.



**H023202** ■  
14 oz. Treva Pilsner  
H 9 3/8" | D 2 7/8"  
2 doz. | 26 lbs. | 1.70 cu. ft.



**80436RT** ■ /80436  
23 oz. Pilsner  
H 9" | D 3 3/8"  
2 doz. | 22 lbs. | 2.16 cu. ft.



**165270**  
13 oz. Empire Pilsner  
H 9 3/8" | D 2 7/8"  
1/2 doz. | 5.1 lbs. | 0.37 cu. ft.

## Table Service

Medium-sized capacity glasses allows for an establishment to provide an upscale service presentation when serving increasingly popular craft beers that are often served in bottles.

## Draft Service

Larger capacity glasses are essential for today's beer service, especially for establishments offering a large assortment of draft beers.



# Stemmed Beer



**2942M**

12 oz. Excellency Beer  
H 7 <sup>7</sup>/<sub>8</sub>" | D 2 <sup>7</sup>/<sub>8</sub>"  
3 doz. | 20 lbs. | 1.63 cu. ft.



**90093**

13 oz. Belgian Beer  
H 5 <sup>3</sup>/<sub>4</sub>" | D 3 <sup>3</sup>/<sub>4</sub>"  
1 doz. | 11 lbs. | 0.94 cu. ft.



**90249**

13 oz. Stemmed Beer  
H 6 <sup>3</sup>/<sub>4</sub>" | D 3 <sup>5</sup>/<sub>8</sub>"  
1 doz. | 7 lbs. | 0.03 cu. ft.



# Beer Mugs



**90132**  
10 oz. Beer Mug  
H 5 1/8" | D 4 5/8"  
2 doz. | 50 lbs. | 1.15 cu. ft.



**1170U**  
10 oz. Beer Tankard  
H 5 7/8" | D 4 7/8"  
1 doz. | 25 lbs. | 0.78 cu. ft.



**01814**  
14 oz. Brew Mug  
H 5 7/8" | D 5"  
2 doz. | 50 lbs. | 1.42 cu. ft.



**01816**  
16 oz. Brew Mug  
H 5 7/8" | D 5"  
2 doz. | 42 lbs. | 1.44 cu. ft.



**18U**  
12 oz. Beer Mug  
H 5 5/8" | D 4 3/4"  
2 doz. | 36 lbs. | 1.27 cu. ft.



**1150U**  
10 oz. Beer Wagon  
H 5 1/8" | D 4 3/8"  
2 doz. | 31 lbs. | 1.04 cu. ft.



**1152U**  
12 oz. Beer Wagon  
H 5 3/4" | D 4 1/2"  
2 doz. | 37 lbs. | 1.22 cu. ft.



**1153U**  
1 Litre Gusto Mug  
H 8" | D 6"  
1 doz. | 39 lbs. | 1.54 cu. ft.



**90272**  
25 oz. Champions Mug  
H 7 1/8" | D 5 5/8"  
1 doz. | 10 lbs. | 1.42 cu. ft.



**162U**  
Boot Mug 12 1/2 oz.  
H 6" | D 5 1/4"  
2 doz. | 27 lbs. | 1.46 cu. ft.

# Beer & Mixing



**77174**  
14 oz. Mixing Glass RT  
H 5 7/8" | D 3 1/2"  
3 doz. | 43 lbs. | 1.86 cu. ft.



**176FU / 7176FU** ■  
16 oz. Mixing Glass  
H 5 7/8" | D 3 1/4"  
2 doz. | 26 lbs. | 1.29 cu. ft.



**90055** ■  
16 oz. Cooler  
H 5 7/8" | D 3 1/4"  
2 doz. | 24 lbs. | 1.31 cu. ft.



**77422** ■  
22 oz. Mixing Glass  
H 6 7/8" | D 3 5/8"  
2 doz. | 27 lbs. | 1.70 cu. ft.



**90244**  
20 oz. English Pub Glass  
H 6" | D 3 2/8"  
1 doz. | 9 lbs. | 0.04 cu. ft.



**90248** ■  
16 oz. Pub Glass  
H 6 1/2" | D 3"  
1 doz. | 8.6 lbs. | 0.48 cu. ft.



**90247** ■  
20 oz. Pub Glass  
H 6 7/8" | D 3 1/4"  
1 doz. | 11 lbs. | 0.90 cu. ft.



**90243**  
20 oz. Tulip Beer  
H 6 1/4" | D 3 1/4"  
1 doz. | 9 lbs. | 0.04 cu. ft.



**90245**  
12 oz. Flared Pilsner  
H 7 1/8" | D 3 1/8"  
1 doz. | 8 lbs. | 0.75 cu. ft.



**90279**  
16 oz. Cyclonic Beer  
H 5 7/8" | D 3 1/4"  
2 doz. | 26 lbs. | 1.29 cu. ft.





## *Florentine*



**80013**  
13 oz. Red Wine  
H 7 3/8" | D 3 5/8"  
2 doz. | 13 lbs. | 1.64 cu. ft.



**80018**  
8 1/2 oz. Wine  
H 7 1/4" | D 2 7/8"  
2 doz. | 11 lbs. | 1.12 cu. ft.



**80019**  
6 oz. Flute  
H 8 1/8" | D 2 1/8"  
2 doz. | 10 lbs. | .99 cu. ft.



**80021**  
11 oz. All Purpose Wine  
H 7 3/8" | D 3 1/4"  
2 doz. | 13 lbs. | 1.37 cu. ft.

## *Carmona*



**96582** ●  
14 oz. White Wine  
H 8 1/4" | D 3 1/4"  
1 doz. | 9 lbs. | 0.92 cu. ft.

## *Grand Wine*



**90240**  
13 oz. All Purpose  
H 8" | D 3 1/8"  
1 doz. | 7 lbs. | 0.17 cu. ft.



**90241**  
11 oz. All Purpose  
H 7 3/4" | D 3"  
1 doz. | 6 lbs. | 0.16 cu. ft.

● Fully  
Tempered

# Excellency Stemware



**2926M**  
6 ½ oz. Wine  
H 5 ¾" | D 2 ⅞"  
3 doz. | 14 lbs. | 1.27 cu. ft.



**2928M**  
8 ½ oz. Wine  
H 5 ⅝" | D 3"  
3 doz. | 19 lbs. | 1.41 cu. ft.



**2930M**  
10 ½ oz. Wine  
H 6" | D 3 ⅜"  
3 doz. | 19 lbs. | 1.80 cu. ft.



**2932M**  
11 ½ oz. Goblet  
H 6" | D 3 ⅞"  
3 doz. | 20 lbs. | 1.72 cu. ft.



**2936M**  
6 ½ oz. Wine  
H 6 ¼" | D 2 ½"  
3 doz. | 15 lbs. | 1.22 cu. ft.



**2938M**  
8 ½ oz. Wine  
H 6 ⅜" | D 2 ¾"  
3 doz. | 16 lbs. | 1.46 cu. ft.



**7221M**  
10 ½ oz. Goblet  
H 5 ¼" | D 3 ⅞"  
3 doz. | 20 lbs. | 1.40 cu. ft.



**10565**  
16 oz. Water Goblet  
H 7" | D 3 ½"  
½ doz. | 7 lbs. | 0.38 cu. ft.



**H001551**  
12 oz. Tall Wine  
H 8" | D 3 ¼"  
1 doz. | 12 lbs. | .75 cu. ft.



**H001420**  
12 oz. White Wine  
H 7 ⅞" | D 3 ¼"  
1 doz. | 10 lbs. | 0.74 cu. ft.



**H001421**  
8 ½ oz. White Wine  
H 5 ⅜" | D 2 ⅞"  
3 doz. | 18 lbs. | 1.52 cu. ft.



# Excellency Stemware



**2907M**  
7 oz. Footed Rocks  
H 4 3/8" | D 3 1/4"  
3 doz. | 20 lbs. | 1.28 cu. ft.



**2908M**  
8 oz. Footed Hi-Ball  
H 5 3/8" | D 2 3/4"  
3 doz. | 20 lbs. | 1.25 cu. ft.



**2910M**  
10 oz. Footed Hi-Ball  
H 6" | D 2 7/8"  
3 doz. | 21 lbs. | 1.39 cu. ft.



**2942M**  
12 oz. Pilsner  
H 7 1/8" | D 2 7/8"  
3 doz. | 20 lbs. | 1.63 cu. ft.



**3933M**  
9 oz. Brandy  
H 4 1/2" | D 3 3/8"  
2 doz. | 12 lbs. | 0.97 cu. ft.



**3951M**  
12 oz. Brandy  
H 4 3/4" | D 3 5/8"  
2 doz. | 13 lbs. | 1.20 cu. ft.



**2085M**  
13 1/2 oz. Pocò  
H 7" | D 3 3/4"  
1 doz. | 9 lbs. | 0.69 cu. ft.



**H001238**  
7 1/4 oz. Flute Champagne  
H 8 1/4" | D 2 1/2"  
1 doz. | 6 lbs. | 0.49 cu. ft.



# Martini



**90063** ●●  
2 ½ oz. Mini Martini  
H 3 ¼" | D 3 ¼"  
3 doz. | 17 lbs. | 0.22 cu. ft.



**90064** ●●  
2 ½ oz. Mini Martini  
H 4 ¾" | D 3 ⅞"  
3 doz. | 18 lbs. | 0.54 cu. ft.



**H037491**  
6 oz. Martini  
H 5 ¾" | D 4 ⅞"  
3 doz. | 17 lbs. | 2.46 cu. ft.



**H037524**  
4 ½ oz. Martini  
H 5 ½" | D 3 ⅞"  
3 doz. | 18 lbs. | 2.15 cu. ft.



**H037525**  
10 oz. Ashbury Martini  
H 6 ¾" | D 4 ⅜"  
1 doz. | 8 lbs. | 1.18 cu. ft.



**80226X** ●  
9 oz. Martini  
H 7" | D 4 ½"  
1 doz. | 7 lbs. | 1.20 cu. ft.



**80278X** ●  
9 oz. Martini  
H 6 ¾" | D 4 ½"  
1 doz. | 7 lbs. | 1.23 cu. ft.



**90032**  
10 ½ oz. Executive Martini  
H 8 ¼" | D 4 ⅓"  
1 doz. | 6 lbs. | 1.92 cu. ft.







**03212**

18 oz. Weiss Goblet  
H 7 1/2" | D 4 3/4"  
1 doz. | 37.7 lbs. | 1.88 cu. ft.

**07767**

20 oz. Weiss Goblet  
H 7 1/2" | D 5"  
1 doz. | 36 lbs. | 1.82 cu. ft.

**07338**

32 oz. Weiss Goblet  
H 8" | D 5 3/8"  
1 doz. | 37.5 lbs. | 2.44 cu. ft.



**3959RTX** ●■

16 oz. Hoffman House Goblet  
H 5 3/4" | D 4"  
2 doz. | 16 lbs. | 1.55 cu. ft.



**10024**

Tiki Cooler 16 oz.  
H 6 1/4" | D 3"  
2 doz. | 25 lbs. | 1.32 cu. ft.

● Proprietary Product ■ Rim Tempered

*Specialty*



**90062** ●●  
3 oz. Mini Wine  
H 4 7/8" | T 1 7/8"  
B 1 7/8" | D 2 1/4"  
3 doz. | 11 lbs. | 0.54 cu. ft.



**80019** ●  
6 oz. Flute  
H 8 1/8" | T 1 7/8"  
B 2 1/2" | D 2 1/8"  
2 doz. | 10 lbs. | .99 cu. ft.



**H001238**  
7 1/4 oz. Flute  
H 8 1/4" | T 2 1/4"  
B 2 3/4" | D 2 1/2"  
1 doz. | 6 lbs. | 0.49 cu. ft.



**2451RTX**  
9 oz. Tulip Champagne  
H 8 1/2" | T 2"  
B 2 7/8" | D 2 3/4"  
1 doz. | 7 lbs. | .69 cu. ft.



**2912UX**  
12 oz. Margarita  
H 6 1/8" | D 4 3/8"  
2 doz. | 17 lbs. | 2.54 cu. ft.



**2914UX**  
14 oz. Margarita  
H 6" | D 4 1/2"  
1 doz. | 9 lbs. | 1.31 cu. ft.



**2095UX**  
15 1/4 oz. Margarita  
H 6" | D 4 7/8"  
1 doz. | 9 lbs. | 1.36 cu. ft.



**2917UX**  
16 3/4 oz. Margarita  
H 6 1/4" | D 5"  
1 doz. | 10 lbs. | 1.39 cu. ft.



**524UX**  
15 oz. Hurricane  
H 8 1/4" | D 3 1/8"  
1 doz. | 11 lbs. | 0.74 cu. ft.



**2085M**  
13 1/2 oz. Poco  
H 7" | D 3 3/8"  
1 doz. | 9 lbs. | 0.69 cu. ft.







## Metal Drinkware

The traditional copper mug is said to enhance the temperature, the aroma, and the overall experience of the Moscow mule. But in modern bars and restaurants, you will find gold, stainless steel, and a variety of colors to not only serve the mixologists' latest crafted cocktails, but appetizers, side dishes, and desserts as well.



**MM1600AC**  
16 oz. Hammered Mug  
Antique Copper  
H 4 1/9" | D 3 3/8"  
1 doz. | 6.25 Lbs | 0.63 cu. ft



**MM1600CP**  
16 oz. Hammered Mug  
Copper Plated  
H 4 1/9" | D 3 3/8"  
1 doz. | 6.25 Lbs | 0.63 cu. ft



**MM1600SS**  
16 oz. Hammered Mug  
Stainless Steel  
H 4 1/9" | D 3 3/8"  
1 doz. | 6.25 Lbs | 0.63 cu. ft



**MM1600GD**  
16 oz. Hammered Mug  
Gold PVD  
H 4 1/9" | D 3 3/8"  
1 doz. | 6.25 Lbs | 0.63 cu. ft

# Perfect Portions



**90062** ●●  
3 oz. Mini Wine  
H 4 <sup>7</sup>/<sub>8</sub>" | D 2 <sup>1</sup>/<sub>4</sub>"  
3 doz. | 11 lbs. | 0.54 cu. ft.



**90063** ●●●  
2 <sup>1</sup>/<sub>2</sub> oz. Mini Martini  
H 3 <sup>1</sup>/<sub>4</sub>" | D 3 <sup>1</sup>/<sub>4</sub>"  
3 doz. | 17 lbs. | 0.22 cu. ft.



**90064** ●●●  
2 <sup>1</sup>/<sub>2</sub> oz. Mini Martini  
H 4 <sup>3</sup>/<sub>4</sub>" | D 3 <sup>1</sup>/<sub>8</sub>"  
3 doz. | 18 lbs. | 0.54 cu. ft.

# Barbary



**93011** ●●  
16 oz. Beer  
H 6 1/8" | D 3 1/4"  
2 doz. | 17 lbs. | 1.90 cu. ft.



**93012** ●●  
13 oz. Beer  
H 6 1/4" | D 2 3/4"  
2 doz. | 10 lbs. | 1.44 cu. ft.



**93013A\*** ●●●  
5 oz. Beer  
H 4" | D 2 1/2"  
2 doz. | 6 lbs. | 0.72 cu. ft.

## Tasters and Shots

Tasters and shot glasses from Anchor Hocking offer an excellent opportunity for any establishment to pre-sell or up-sell their beverage service by providing truly unique presentations that can be tailored to any décor.

## Score Bigger Profits

Use serving paddles to increase your sales and profits. Serve customers four different beers (for your 13 oz. price) using 4.5 oz. taster.



**90038** ●  
Serving Paddle  
H 5/8" | L 14 1/2"  
1 doz. | 8 lbs. | .30 cu. ft.

**11938**  
Serving Paddle - Acacia Wood  
H 5/8" | L 14 1/2"  
1 doz. | 14 lbs. | .39 cu. ft.

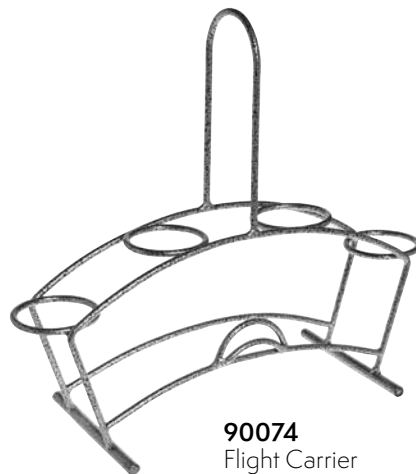

**90074**  
Flight Carrier  
H 7" | D 5 1/4"  
1 doz. | 14 lbs. | 4.03 cu. ft.



● Proprietary Product ● Can be used with Serving Paddle



# Shot Glasses & Shooters



**163Q**  
3 ½ oz. Taster  
H 2 ¾" | D 2"  
3 doz. | 8 lbs. | 0.39 cu. ft.



**2283Q**  
3 oz. Whiskey/Taster  
H 2 ⅝" | D 2 ⅛"  
3 doz. | 10 lbs. | 0.39 cu. ft.



**3661U**  
1 ½ oz. Whiskey  
H 2 ¼" | D 2"  
6 doz. | 16 lbs. | 0.55 cu. ft.



**3666EU** ★  
¾ oz. Whiskey  
H 2 ¼" | D 1 ⅞"  
6 doz. | 26 lbs. | 0.83 cu. ft.



**3668U**  
1 oz. Whiskey  
H 2 ¼" | D 2"  
6 doz. | 22 lbs. | 0.55 cu. ft.



**5280VU** ★  
1 ¼ oz. Whiskey  
H 2 ⅞" | D 2 ¼"  
6 doz. | 43 lbs. | 1.15 cu. ft.



**5281U** ★  
1 ½ oz. Whiskey  
H 2 ⅞" | D 2 ¼"  
4 doz. | 27.5 lbs. | 0.77 cu. ft.



**5280/1612UL**  
1 ¼ oz. Line Whiskey  
(with ½ oz. cap line)  
H 2 ⅞" | D 2 ¼"  
6 doz. | 43 lbs. | 1.15 cu. ft.



**5281/931U** ★  
1 ½ oz. Line Whiskey  
(with ¾ oz. cap line)  
H 2 ⅞" | D 2 ¼"  
4 doz. | 27.5 lbs. | 0.77 cu. ft.



**5281/932U** ★  
1 ½ oz. Line Whiskey  
(with ⅞ oz. cap line)  
H 2 ⅞" | D 2 ¼"  
4 doz. | 27.5 lbs. | 0.77 cu. ft.



**5282/928U** ★  
2 oz. Line Whiskey  
(with 1 oz. cap line)  
H 2 ⅞" | D 2 ¼"  
4 doz. | 23.3 lbs. | 0.77 cu. ft.



**5282U**  
2 oz. Whiskey  
H 2 ⅞" | D 2 ¼"  
4 doz. | 23.3 lbs. | 0.77 cu. ft.



**3667EU**  
⅞ oz. Whiskey Glass  
H 2 ¼" | D 2"  
6 doz. | 24 lbs. | 0.79 cu. ft.



**90246**  
1 ½ oz. Tequila Shooter  
H 2 ⅞" | D 1 ¾"  
6 doz. | 24 lbs. | 0.62 cu. ft.



**90069**  
3 ½ oz. Beer Taster Mug  
H 3 ¼" | D 3 ⅜"  
6 doz. | 41 lbs. | 1.38 cu. ft.



**90063** ● ● ● ●  
2 ½ oz. Mini Martini  
H 3 ¼" | D 3 ¼"  
3 doz. | 29 lbs. | 0.22 cu. ft.

# Water Bottles



**11935**  
¼ L Round Water Bottle  
(with ceramic cap)  
H 8" | D 3"  
2 doz. | 8.4 lbs. | .69 cu. ft.



**11936**  
½ L Round Water Bottle  
(with ceramic cap)  
H 10" | D 3½"  
1 doz. | 11.90 lbs. | .69 cu. ft.



**11937**  
1 L Round Water Bottle  
(with ceramic cap)  
H 12½" | D 3½"  
1 doz. | 18.3 lbs. | 1.44 cu. ft.



**W99247R**  
750 mL Stockholm Bottle  
H 8¾" | D 4"  
½ doz. | 10.3 lbs. | .58 cu. ft.



**W99248**  
750 mL Milan Bottle  
H 8¾" | D 4"  
½ doz. | 10.3 lbs. | .58 cu. ft.



**W99249**  
750 mL Edinburgh Bottle  
H 8¾" | D 4"  
½ doz. | 10.3 lbs. | .58 cu. ft.



**93411R**  
750 mL Stockholm Bottle  
H 8¾" | W 4" | D 4"  
½ doz. | 10.3 lbs. | .58 cu. ft.



**93221**  
2 qt. Bistro Pitcher w/White Stopper  
H 10¼" | W 5½" | D 3¼"  
½ doz. | 10.3 lbs. | .58 cu. ft.

# Pitcher & Carafes



**1155UR** ■  
55 oz. Beer Wagon Pitcher  
H 9 ⅞" | D 7"  
½ doz. | 24 lbs. | 1.20 cu. ft.



**121UR**  
½ L Carafe  
H 9" | D 3 ¼"  
1 doz. | 16 lbs. | 0.86 cu. ft.



**139UR**  
1 L Carafe  
H 11" | D 4 ⅞"  
1 doz. | 25 lbs. | 1.62 cu. ft.



**93084**  
1 L Carafe (with lid)  
H 11" | D 4 ⅞"  
½ doz. | 13.6 lbs. | .81 cu. ft.

■ Rim  
Tempered

# Dessert



**90060**  
16 oz. Soda Glass  
H 8 ¼" | D 3 ⅝"  
1 doz. | 20 lbs. | 1.12 cu. ft.



**562U**  
12 ½ oz. Soda  
H 6 ¾" | D 3 ⅝"  
3 doz. | 40 lbs. | 2.26 cu. ft.



**575GU**  
4 ½ oz. Footed Sherbet  
H 4 ⅞" | D 3 ⅝"  
3 doz. | 20 lbs. | 1.32 cu. ft.



**56EU**  
5 oz. Waverly Sherbet  
H 2 ¼" | D 3 ¾"  
3 doz. | 15 lbs. | 0.51 cu. ft.



**561G**  
8 ¼ oz. Banana Split  
H 1 ⅝" | D 8 ¼"  
1 doz. | 10 lbs. | 0.48 cu. ft.



**340Q**  
25" Cake Dome  
H 7 ¼" | D 11 ⅜"  
4 ea. | 21 lbs. | 2.49 cu. ft.

# La Rochere



**622301**  
1 ½ oz. Mini Bubble  
H 2 ½" | D 3 ⅞"  
1 doz. | 3.1 lbs. | 0.19 cu. ft.



**617801**  
4 ½ oz. Bubble  
H 3 ⅝" | D 4 ¾"  
1 doz. | 11.4 lbs. | 0.56 cu. ft.



**617901**  
5 oz. Vega Cup - Clear  
H 3 ⅞" | D 3 ¾"  
1 doz. | 6.3 lbs. | 0.42 cu. ft.



**628701**  
8 ½ oz. Cafet Cup  
H 2 ⅜" | D 5"  
1 doz. | 6.3 lbs. | 0.70 cu. ft.



**608601**  
6 ½ oz. Diamond Cup  
H 3 ⅜" | D 4 ⅜"  
1 doz. | 6.1 lbs. | 0.42 cu. ft.



**604001**  
7 oz. Fidji Sundae  
H 6" | D 4"  
1 doz. | 11.9 lbs. | 0.84 cu. ft.



**605001**  
7 ½ oz. Omega Dish  
H 5" | D 5"  
1 doz. | 11.1 lbs. | 1.02 cu. ft.



**618601**  
13 ½ oz. Elise Dish  
H 4 ⅞" | D 5"  
1 doz. | 10.7 lbs. | 0.91 cu. ft.



**627701**  
7 ½ oz. Champagne Cup  
H 3 ⅞" D 4"  
12 doz. | 8.1 lbs. | 0.64 cu. ft.

# Coffee Mugs



**308U**  
8 oz. Irish Coffee  
H 5 ¼" | D 4"  
2 doz. | 20 lbs. | 1.05 cu. ft.



**90284**  
14 oz. Rio Mug  
H 4" | D 3 ½"  
1 doz. | 12 lbs. | 0.61 cu. ft.



**83037A** ●  
14 oz. Mocha Mug  
H 5 ⅝" | D 5 ¼"  
½ doz. | 7 lbs. | 0.45 cu. ft.



**83045A** ●  
16 oz. Cafe Mug  
H 5" | D 5 ¼"  
½ doz. | 7 lbs. | 0.42 cu. ft.

● Proprietary Product





# Salt & Pepper



**1830EU**  
2 oz. Crystal Salt/Pepper  
H 3 3/8" | D 1 5/8"  
3 doz. | 7 lbs. | 0.25 cu. ft.



**16U**  
2 oz. Salt/Pepper  
H 4 1/4" | D 2 1/8"  
2 doz. | 11 lbs. | 0.25 cu. ft.



**80570**  
2 oz. Continenta Salt/Pepper  
H 4 1/4" | D 2 1/8"  
2 doz. | 11 lbs. | 0.25 cu. ft.



**90079**  
2 oz. Square Salt/Pepper  
H 3 3/8" | D 1 5/8"  
2 doz. | 9 lbs. | 0.18 cu. ft.



**39122**  
3 1/4 oz. Swirl Salt/Pepper  
H 3 3/8" | D 1 5/8"  
1 doz. | 2 lbs. | .13 cu. ft.

# Votives



**99005**  
12 oz. Flared Square  
H 4" | D 3 1/4"  
1/2 doz. | 5 lbs. | 0.80 cu. ft.



**99006**  
5 oz. Flared Square  
H 3" | D 2 1/4"  
1/2 doz. | 3.5 lbs. | 0.15 cu. ft.



**3354KR1**  
Ivy Ball  
H 3 7/8" | D 4"  
1 doz. | 6 lbs. | 0.57 cu. ft.



**3355DHR1**  
Footed Ivy Ball  
H 5 3/8" | D 4 3/4"  
1 doz. | 6 lbs. | 0.57 cu. ft.

# Ashtrays



**143U**  
3 5/8" Square  
H 3 3/4" | D 3 5/8"  
3 doz. | 21 lbs. | 0.46 cu. ft.



**148U**  
4 3/8" Round Snuffer  
H 1 1/8" | D 4 3/8"  
3 doz. | 21 lbs. | 0.66 cu. ft.



**44912**  
5 3/4" Executive  
N/A" | D 3 3/4"  
1/2 doz. | 12 lbs. | 0.29 cu. ft.

# Care & Handling

**Mechanical Shock:** When glassware comes in sudden contact with any hard surface or object, whether it's another glass, the countertop, or a beer tap, small abrasions are created which weaken the surface and increase the chance of breakage and chipping.

Never stack glasses. Avoid glass to glass contact in all instances

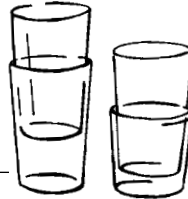

Do not use glassware for storage of flatware.



Separate glassware, flatware and china in bus trays.



Never pick up glasses in bouquets.

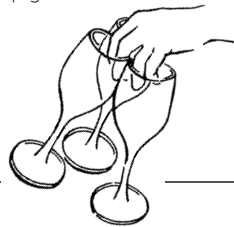

Never pour cold liquid into a hot glass, such as one just out of the dishwasher, or hot liquid into a cold glass.



Never scoop ice with a glass. Use a plastic scoop.



Empty ice from glass before sorting bus tray, this allows more time for the glass to reach room temperature before washing.

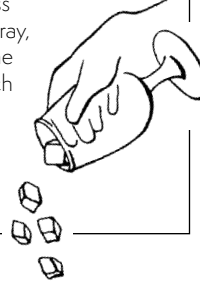

Keep an adequate backup supply of glasses. A recently washed glass should be allowed to reach room temperature before being placed back in service.

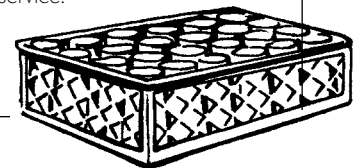

Utilize the correct rack system for tumblers and stems. A divided rack is always recommended.

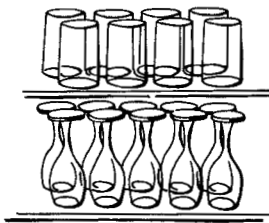

**Thermal Shock:** The result of a rapid temperature change in the glassware which can create stress and/or cracking.

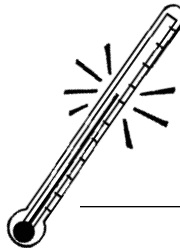

# *Tools of the Trade*

## *Service Setting*

An adequate inventory of glassware in a foodservice operation or bar will help decrease breakage, because if supplies are short, workers must handle glasses faster and less carefully. These charts offer not hard-and-fast rules, but only suggested requirements.

## *Custom Capabilities*

In addition to our expansive foodservice product line, Anchor Hocking offers a full range of value-added solutions to meet your individual needs. Choose from customized products that are unique to your company or special packaging that can help build your brand name. Our goal is to provide not only quality glassware to our customers, but quality solutions.

## *Silk Screen Decorating    Product Modifications*

Promote your company logo through a durable lead-free silk-screen decoration. Available in one to five colors.

Create new, unique items built around your company name or logo.

## *Unique Decorating*

Add color to any existing glassware item to create a bold impression.

## *Custom Packaging*

Develop unique cartons to fit your specific pack, material, and label requirements.

# Glassware Requirements

## Sample Bar Glassware Requirements

(per 100 seats)

Item	Capacity	Bar	Rest. Bar
Beer	6 - 12 oz.	12 dz.	12 dz.
Champagne	3.5 - 3 oz.	3 dz.	3 dz.
Cocktail	3 - 6 oz.	9 dz.	6 dz.
Hi-Ball	7 - 11 oz.	12 dz.	9 dz.
Wine	6.5 - 9 oz.	6 dz.	9 dz.
Sours	5 - 6 oz.	3 dz.	3 dz.
Rocks	4 - 7 oz.	9 dz.	6 dz.
Cordials	.75 - .5 oz.	3 dz.	3 dz.
Collins	9 - 12 oz.	3 dz.	3 dz.
Brandy	5.5 - 34 oz.	3 dz.	3 dz.

## Sample Foodservice Glassware Requirements

(per 100 seats)

Item	Coffee Shop	Dining Room	Banquet
Juice Glasses	24 dz.	12 dz.	12 dz.
Water Glasses	36 dz.		
Iced Tea Glasses	24 dz.	12 dz.	12 dz.
Water Goblets		24 dz.	18 dz.
Sherbet Glasses		12 dz.	12 dz.
Fruit Cocktail Glasses		12 dz.	12 dz.
Champagne Glasses			12 dz.
Parfait Glasses		12 dz.	12 dz.





# Our Promise to You

## Longer Life, Lower Replacement Costs

Anchor Hocking foodservice products are made stronger, more durable by special manufacturing processes:

**RIM-TEMPERED** products (sometimes referred to as heat treated) are similar to fully-tempered, except that the heat is concentrated on the rim area, followed by the cooling process, allowing for a stronger more durable product.

---

# SureGuard™ Guarantee

## Most Extensive Guarantee in the Industry

Anchor Hocking guarantees its entire foodservice line against chipping. If the rim of a tumbler or the foot or rim of a piece of stemware chips in normal use, Anchor Hocking will replace the item or refund the purchase price when returned to the dealer or distributor from whom it was purchased. Products in the foodservice line are defined as all active products in the foodservice price list. Naturally, this guarantee does not cover breakage.

**World Headquarters**

200 Civic Center Drive  
Suite 700  
Columbus, OH 43215  
USA

**Customer Service**

**Phone:** 1.800.828.7033  
**customersupport-foodservice@theoneidagroup.com**

**foodservice.oneida.com**

**ONEIDA®**  
Designing the dining experience.™

All pattern names and designs are intellectual properties of Oneida, Ltd., a subsidiary of The Oneida Group Inc.  
Oneida® is a registered trademark of Oneida, Ltd. in the U.S. and certain countries.  
200 S. Civic Center Drive, Suite 700, Columbus, OH 43215. ©2018 Oneida, Ltd. All rights reserved.

Anchor Hocking® and the Anchor Hocking logo are registered trademarks of  
Anchor Hocking, LLC, a subsidiary of The Oneida Group Inc. in the U.S. and certain countries.  
200 S. Civic Center Drive, Suite 700, Columbus, OH 43215. ©2018 Anchor Hocking, LLC. All rights reserved.